

# DEVELOPMENT OF A BILATERAL RIGID STERNUM CLOSURE TESTING SYSTEM

MAY 2010  
A MAJOR QUALIFYING PROJECT REPORT:  
SUBMITTED TO THE FACULTY OF THE  
WORCESTER POLYTECHNIC INSTITUTE  
IN PARTIAL FULFILLMENT OF THE REQUIREMENTS FOR THE  
DEGREE OF BACHELOR OF SCIENCE  
BY

---

LYDIA BAKALOVA

---

STEVEN CHUNG

---

HANNAH SHAPIRO

---

ROXANNE SKOWRAN

1) Sternum

---

Prof. George Pins, Major Advisor

2) Rigid fixation

---

Prof. Kristen Billiar, Major Advisor

3) Bone screws

---

Prof. Krystyna Gielo-Perczak, Co-Advisor

---

Dr. Raymond Dunn, Co-Advisor

## ACKNOWLEDGEMENTS

We would like to thank the many individuals who helped us throughout our project. First of all, we would like to thank our advisor George Pins, Ph.D., and co-advisor Krystyna Gielo-Perczak, Ph.D., for all of their help guiding us through our research. We would also like to thank Raymond Dunn, M.D., Ronald Ignatz, Ph.D., and Janice Lalikos, M.D. from the UMass Medical School for all of their valuable input and guidance, arranging the hardware applications, and donating a cadaveric sternum for testing. We would like to thank Russell Babbitt, M.D., Zach Hurwitz, M.D., Richard Montilla, M.D., Elan Witkowski, M.D., and Julie O'Brien, M.D. at UMass Medical School for the numerous hours they spent applying hardware to our samples. We would like to thank Kevin Mulgrew, Shawn Burke, and Christian Leibinger from KLS Martin L.P. for their generosity in donating all of the hardware and polyurethane bone model used in testing. Additionally we would like to thank Neil Whitehouse and Jack Ferraro from the mechanical engineering and chemical engineering department machine shops for their help and guidance in building and maintaining our testing device. Lastly, we would like to thank Lisa Wall for her help in the lab, particularly with the Instron, and helping us with lab access.

## AUTHORSHIP

All group members contributed equally to the device design, testing, writing and construction of this report.

## ABSTRACT

The goal of this project was to design and develop a bilateral rigid sternal fixation testing system to mimic *in vivo* breathing forces and to measure anterior dehiscence, posterior splay, and screw loosening of bisected sternal halves. Custom fixtures and Bluehill program were developed to perform testing using an Instron machine. Dehiscence, splay, and screw loosening were measured before and after testing to analyze the effectiveness of various hardware types to minimize these measurements. Overall, unicortical and bicortical configurations were found to perform similarly in polyurethane bone model [p = 0.98], and unicortical configurations performed better than bicortical in cadaveric tissue [p = 0.01]. Two point three millimeter diameter screws seem to perform better than 2.0mm and 2.7mm diameter screws [p = 0.26]. Standard and locking plates comparably minimized bone separation and screw loosening [p = 0.97]. The results of this research provide a basis for future research in rigid sternal fixation systems.

## TABLE OF CONTENTS

|  |           |
|--|-----------|
| <b>Acknowledgements .....</b>  | <b>2</b>  |
| <b>Authorship .....</b>  | <b>3</b>  |
| <b>Table of Tables .....</b>   | <b>13</b> |
| <b>Chapter 1. Introduction .....</b>   | <b>14</b> |
| <b>Chapter 2. Background .....</b>   | <b>17</b> |
| <b>2.1 Clinical Need Statistics .....</b>  | <b>17</b> |
| <b>2.2 Human Sternum Anatomy and Physiology .....</b>  | <b>18</b> |
| <b>2.3 Biological Factors with Rigid Fixation .....</b>  | <b>21</b> |
| 2.3.1 Strain Theory.....   | 21        |
| <b>2.4 Screw Characteristics .....</b>   | <b>22</b> |
| <b>2.5 Unicortical and Bicortical Configurations .....</b>                                     | <b>24</b> |
| <b>2.6 Plate Characteristics.....</b>  | <b>25</b> |
| 2.6.1 Distance between Bone and Plate.....   | 25        |
| <b>2.7 Plate Design.....</b>   | <b>26</b> |
| 2.7.1 Straight Plates.....   | 27        |
| 2.7.2 Sternum Plates.....  | 29        |
| 2.7.3 X-Plates and H-Plates.....   | 30        |
| 2.7.4 Plate Mechanics.....   | 31        |
| <b>2.8 Fixtures to test Fixation Systems .....</b>   | <b>32</b> |
| <b>2.9. Mathematical Modeling .....</b>  | <b>37</b> |
| 2.9.1 Mathematical Equations.....  | 37        |
| 2.9.2 Mathematical Models.....   | 38        |
| <b>Chapter 3. Project Strategy .....</b>   | <b>41</b> |
| <b>3.1 Client Statement and Design Goals .....</b>   | <b>41</b> |
| 3.1.1 Initial Client statement .....   | 41        |
| 3.1.2 List of Objectives for Bilateral Testing Method .....                                    | 42        |
| 3.1.3 Objectives Tree for Bilateral Testing Method.....  | 43        |
| 3.1.4 Functionsfor Bilateral Testing Method .....  | 44        |
| 3.1.5 Constraints for Bilateral Testing Method .....   | 44        |
| 3.1.6 Design Specifications for Sternal Closure Testing Device.....                            | 45        |
| <b>3.2 Experimental Design .....</b>   | <b>45</b> |
| 3.2.1 Pairwise Comparison Chart for Major Design Objectives for Bilateral Testing Method ..... | 46        |
| 3.2.2 Needs analysis .....   | 46        |
| 3.2.3 Revised Client Statement.....  | 48        |
| <b>3.3 Conceptual Design .....</b>   | <b>49</b> |
| 3.3.1 Gripping .....   | 49        |
| 3.3.2 Angling Grip .....   | 50        |

|   |            |
|---|------------|
| 3.3.3 Screw Loosening .....   | 51         |
| 3.3.4 Bone/Plate Displacement .....   | 52         |
| <b>3.4 Design Alternatives .....</b>  | <b>53</b>  |
| 3.4.1 Design Alternative 1: Epoxy Putty Cups with Ratcheting Mechanism for Grip Angling ..... | 53         |
| 3.4.2 Design Alternative 2: reference Bars and PMMA method .....                              | 55         |
| 3.4.3 Design Alternative 3: PMMA Guided aluminum Method.....                                  | 57         |
| 3.4.4 Design Alternative 4.....   | 60         |
| 3.4.5 design Alternative 5.....   | 61         |
| 3.4.6 Selecting the Final Design .....  | 62         |
| 3.4.7 Final Design for Bilateral tesing device.....   | 63         |
| <b>3.5 Methodology .....</b>  | <b>65</b>  |
| 3.5.1 Hypotheses .....  | 65         |
| 3.5.2 Power analysis .....  | 66         |
| 3.5.3 Sternum And Fixture Preparations .....  | 70         |
| 3.5.4 Programming .....   | 72         |
| 3.5.5 Pre and Post Test Measurements.....   | 73         |
| 3.5.6 Image Processing .....  | 74         |
| 3.5.7 Validation of Testing Method .....  | 76         |
| 3.5.8 Data Analysis.....  | 78         |
| <b>Chapter 4. Results/Discussion.....</b>   | <b>82</b>  |
| <b>4.1 Pre-testing results for first hardware application .....</b>                           | <b>82</b>  |
| 4.1.1 Comparative Analyses of Individual Sternum.....   | 83         |
| 4.1.2 Comparative Analyses of Individual rib pairs .....                                      | 88         |
| 4.1.3 Comparative Analyses of different fixation systems .....                                | 93         |
| <b>4.2 Pre-testing results for all tests .....</b>  | <b>101</b> |
| 4.2.1 Comparative Analyses of individual Rib Pairs.....                                       | 102        |
| 4.2.2 Comparative Analyses of different fixation systems .....                                | 105        |
| 4.2.3 Correlation of Pre-testing Measurements and setup failures.....                         | 110        |
| <b>4.3 Post-testing data results of image processing.....</b>                                 | <b>112</b> |
| <b>4.4 Post-testing analysis of Bone separation and Screw loosening.....</b>                  | <b>116</b> |
| 4.4.1 Hypothesis 1: Bone/ screw interface.....  | 116        |
| 4.4.2 Hypothesis 2: Bone/plate and screw/plate interfaces .....                               | 123        |
| <b>4.5 Results of Computer Simulation .....</b>   | <b>126</b> |
| <b>Chapter 5. Project Considerations.....</b>   | <b>131</b> |
| 5.1 Economic.....   | 131        |
| 5.2 Environmental Impact .....  | 131        |
| 5.3 Societal Influences and Political Ramifications.....                                      | 132        |
| 5.4 Ethical Considerations .....  | 132        |
| 5.5 Health and Safety Issues.....   | 132        |
| 5.6 Manufacturability .....   | 133        |

|   |            |
|---|------------|
| 5.7 Sustainability.....   | 133        |
| <b>Chapter 6. Final Design and Verification.....</b>  | <b>134</b> |
| <b>Chapter 7. Conclusion and Future Recommendations .....</b>   | <b>136</b> |
| <b>References .....</b>   | <b>140</b> |
| <b>Appendix A- Dr. Raymond Dunn’s Pairwise Comparison Charts for the Bilateral Testing Method .....</b>                 | <b>143</b> |
| <b>Appendix B- Dr. Janice Lalikos’ Pairwise Comparison Charts for the Bilateral Testing Method .....</b>                | <b>148</b> |
| <b>Appendix C- Dr. Ronald Ignotz’s Pairwise Comparison Charts for the Bilateral Testing Method .....</b>                | <b>153</b> |
| <b>Appendix D- Professor George Pins’ Pairwise Comparison Charts for the Bilateral Testing Method .....</b>             | <b>158</b> |
| <b>Appendix E- Professor Krystyna Gielo-Perczak’s Pairwise Comparison Charts for the Bilateral Testing Method .....</b> | <b>163</b> |
| <b>Appendix F - Dr. Janice Lalikos’ Pairwise Comparison Charts for the Bilateral Testing Method .....</b>               | <b>168</b> |
| <b>Appendix G - Dr. Ronald Ignotz’s Pairwise Comparison Charts for the Bilateral Testing Method .....</b>               | <b>173</b> |
| <b>Appendix H- Power Analysis .....</b>   | <b>178</b> |
| <b>Appendix I- Meeting Minutes with UMMS Stakeholders .....</b>   | <b>180</b> |
| <b>Appendix J- Budget Analysis .....</b>  | <b>184</b> |
| <b>Appendix K - Glossary.....</b>   | <b>186</b> |
| <b>Appendix L - Drawings of final testing method design .....</b>   | <b>188</b> |
| <b>Appendix M – Full list of hardware provided by kls martin inc.....</b>   | <b>196</b> |
| <b>Appendix N - Full List of Assembled Sternal Rib samples .....</b>  | <b>197</b> |
| <b>Appendix O – procedure for sample potting and loading in the Instron .....</b>                                       | <b>210</b> |
| <b>Appendix P – Instron Machine Specifics (Instron 5544).....</b>   | <b>219</b> |
| <b>Appendix Q - Full Protocol .....</b>   | <b>221</b> |
| <b>Appendix R - ImageJ processing Procedure .....</b>   | <b>225</b> |
| <b>Appendix S – Full list of load cell data analysis .....</b>  | <b>229</b> |

**Appendix T – Full list of screw hole measurements ..... 242**  
**Appendix U – Full list of tested samples (pass/fail)..... 244**



## TABLE OF FIGURES

|   |    |
|---|----|
| Figure 1: Adult Sternum Anatomy (Grey, 1918) Copyright Pending.....   | 19 |
| Figure 2: a) Cortical Screw, b) Cancellous Screw (Crown Metal Works, 2009).....   | 22 |
| Figure 3: Pictorial Demonstration of Various Screw Characteristics (Medscape, 2009) Requesting Copyright permission.....  | 23 |
| Figure 4: A side view of unicortical and bicortical screws within the sternum .....   | 24 |
| Figure 5: Failure scenarios using bicortical configurations (Ahn, 2009).....  | 25 |
| Figure 6: Plate spacing configurations for testing – DCP (Dynamic Compression Plates) and LCP (Locked Compression Plates) (Ahmad, 2007) (Copyright pending) .....   | 26 |
| Figure 7: Three types of plates (Dynamic Compression plate (DCP), low contact- dynamic compression plate (LC-DCP), and low contact locking plate (PC-Fix) demonstrating screw hole variability and topography (Shutz, 2003) (Copyright pending) ..... | 28 |
| Figure 8: A close up view of the Hybrid Screw Design on the left and a view of how each screw can be utilized on the right (Shutz, 2003) (Copyright pending) .....  | 29 |
| Figure 9: X-plate use in Sternum Closure (Raman, 2007) (Copyright pending) .....  | 30 |
| Figure 10: Custom made H-plate from KLS-Martin L.P. (Ozaki, 1998) (Copyright pending) .....   | 31 |
| Figure 11: Rigid Cage Testing Method (McGregor, Trumble, & Magovern, 1999) .....  | 33 |
| Figure 12: Three Testing Directions: <i>left</i> , lateral [X-direction]; <i>center</i> , anterior-posterior [Y-direction]; <i>right</i> , rostral-caudal [Z-direction] (McGregor, Trumble, & Magovern, 1999) .....                                   | 33 |
| Figure 13: PMMA and Aluminum Casing Grip: <i>a.</i> testing in the lateral direction, <i>b.</i> testing in the anterior-posterior direction, <i>c.</i> testing in the rostral-caudal direction (Cohen & Griffin, 1999).....                           | 34 |
| Figure 14: Epoxy Putty and PVC Cap Grip (Decoteau et al., 2006) .....   | 35 |
| Figure 15: Tethering Gripping System Made of Pulleys and Pivots (Pai et al., 2005) .....  | 36 |
| Figure 16: Illustration of (A) stress for intact sternum [N/mm <sup>2</sup> ]; (B) stress for simple-wire loop [N/mm <sup>2</sup> ]; and (C) stress for figure-of-eight loop [N/mm <sup>2</sup> ]. Requesting copyright permission .....              | 39 |
| Figure 17: Numeric ranking of testing device objectives ranked by stakeholders and advisors.....  | 47 |
| Figure 18: a) Basic epoxy putty method, b) guided channel method, c) referencing bar method, d) PMMA tab method.....  | 50 |
| Figure 19: a) Guided epoxy putty caps with ratcheting arm attachment, b) guided channel method, c) referencing bar method.....  | 51 |

|  |    |
|--|----|
| Figure 20 Epoxy Putty Cups with Ratcheting Arm for Angulation a) Assembled testing fixture, b) PVC Cups to be filled with epoxy putty, c) Aluminum arm with ratcheting mechanism to attach to Instron (measurements are in mm) ..... | 55 |
| Figure 21: Reference Bars and PMMA method a) Outer box with reference lever, b) reference bar system .....   | 56 |
| Figure 22: PMMA Guided Aluminum Grip (measurements in millimeters) .....   | 59 |
| Figure 23: Two Parts of the Aluminum Box .....   | 59 |
| Figure 24: Design Alternative 4 – a) Side views of Aluminum Compression Box method; b) Front View; c) Overview of whole fixture .....  | 60 |
| Figure 25: Design Alternative 5 - Metal box with guiding rails (all dimensions are in millimeters) .....   | 61 |
| Figure 26: Final Design of Bilateral Testing Device a) view from top angle, b) view from bottom angle .....  | 64 |
| Figure 27: Depiction of the three interfaces and the three measurements taken before and after testing .....   | 66 |
| Figure 28: Sternum divided in 6 rib pairs .....  | 69 |
| Figure 29: Images taken prior to testing on the anterior and posterior side .....  | 75 |
| Figure 30: Documented measurements using ROI manager showing the distance between the centroid of each dot .....   | 76 |
| Figure 31: Screw loosening measurement .....   | 79 |
| Figure 32: Polyurethane rib pair used for computer simulation modeling (Sample B3) .....   | 81 |
| Figure 33: Schematic of how plate centering was measured during pre-testing .....  | 83 |
| Figure 34: Plate contouring .....  | 83 |
| Figure 35: Schematic of how plate angle was measured during pre-testing measurements. ....   | 83 |
| Figure 36: Plate centering for each sternum independent of the types of plates and screws applied.....   | 84 |
| Figure 37: Plate contouring for each sternum independent of the types of plates and screws applied .....   | 85 |
| Figure 38: Plate placement for each sternum independent of types of plates and screws applied. 90° is the ideal angle of the plate from the sternal cut. ....  | 86 |
| Figure 39: Looseness of the bone/plate/screw system for each sternum independent of the types of plates and screws applied. A rank of 5 is very rigid and a 1 means the system fell apart. ....                                      | 87 |
| Figure 40: Pictorial representation defining the 6 rib pairs of a sternum. Rib pair 1 is the manubrium, rib pairs 2-5 are the body, and rib pair 6 is the xiphoid region. ....   | 88 |
| Figure 41: Plate centering for each rib pair independent of the types of plates and screws applied.....  | 89 |
| Figure 42: Plate contouring for each rib pair independent of the types of plates and screws applied .....  | 90 |

|   |     |
|---|-----|
| Figure 43: Plate placement for each rib pair independent of the types of plates and screws applied. 90° is the ideal angle of the plate from the sternal cut.....                               | 91  |
| Figure 44: Looseness of the bone/plate/screw system independent of the types of plates and screws applied. A rank of 5 is very rigid and a 1 means that the system fell apart. ....             | 92  |
| Figure 45: Comparison of plate centering for unicortical and bicortical configurations .....  | 94  |
| Figure 46: Comparison of plate contouring for unicortical and bicortical configurations .....   | 94  |
| Figure 47: Comparison of plate placement for unicortical and bicortical configurations. 90° is the ideal angle of the plate from the sternal cut. ....  | 95  |
| Figure 48: Comparison of the looseness of the bone/plate/screw system for unicortical and bicortical configurations. A rank of 5 is very rigid and a rank of 1 means the system fell apart..... | 95  |
| Figure 49: Comparison of plate centering for different diameter screws .....  | 96  |
| Figure 50: Comparison of plate contouring for different diameter screws .....   | 97  |
| Figure 51: Comparison of plate placement for different diameter screws. 90° is the ideal angle of the plate from the sternal cut.....   | 97  |
| Figure 52: Comparison of the looseness of the bone/plate/screw system for different diameter screws. A rank of 5 is very rigid and a 1 means that the system fell apart.....                    | 98  |
| Figure 53: Comparison of plate centering for different plate types .....  | 99  |
| Figure 54: Comparison of plate contouring for different plate types.....  | 99  |
| Figure 55: Comparison of plate placement for different plate types. 90° is the ideal angle from the plate to the sternal cut.....   | 100 |
| Figure 56: Comparison of the looseness of the bone/plate/screw system for different plate types. A rank of 5 is very rigid and a 1 means that the system fell apart. ....                       | 100 |
| Figure 57: Analysis of vertical plate centering for each rib pair.....  | 102 |
| Figure 58: Analysis of horizontal plate centering for each rib pair. ....   | 104 |
| Figure 59: Analysis of plate contouring for each rib pair. ....   | 105 |
| Figure 60: Comparison of unicortical and bicortical configurations with respect to vertical plate centering.....  | 106 |
| Figure 61: Comparison of different diameter screws with respect to vertical plate centering.....  | 106 |
| Figure 62: Comparison of different fixation systems with respect to vertical plate centering.....   | 107 |
| Figure 63: Comparison of unicortical and bicortical configurations with respect to horizontal plate centering. ....   | 108 |
| Figure 64: Comparison of different diameter screws with respect to horizontal plate centering.....  | 108 |
| Figure 65: Comparison of different fixation systems with respect to horizontal plate centering. ....  | 109 |

|   |     |
|---|-----|
| Figure 66: Comparison of different fixation systems with respect to plate contouring. ....                      | 110 |
| Figure 67: Setup failure rates with respect to different setup features. ....                                   | 111 |
| Figure 68: Side view of a sample with an increased amount of splay .....  | 112 |
| Figure 69: Frontal view of a sample with a considerable gap on one side .....                                   | 113 |
| Figure 70: Anterior dehiscence using the ImageJ analysis .....  | 114 |
| Figure 71: Posterior splay using the ImageJ analysis .....  | 114 |
| Figure 72: Average Bone Separation Analysis for unicortical vs. bicortical configurations .....                 | 117 |
| Figure 73: Percent screw loosening Analysis for unicortical vs. bicortical configurations .....                 | 118 |
| Figure 74: comparison between unicortical and bicortical configuration based on cadaveric sternal testing ..... | 120 |
| Figure 75: Comparison of bone separation for different major screw diameters .....                              | 121 |
| Figure 76: Comparison of percent screw loosening for different major screw diameters .....                      | 122 |
| Figure 77: Comparison of average bone separation for different fixation systems .....                           | 124 |
| Figure 78: Comparison of percent screw loosening for different fixation systems .....                           | 125 |
| Figure 79: Working Model 2D - Model of a straight plate .....   | 126 |
| Figure 80: Working Model 2D - Model of an offset plate .....  | 127 |
| Figure 81: Working Model 2D - Model of an angled plate .....  | 128 |



## TABLE OF TABLES

|  |     |
|--|-----|
| Table 1 Comparison of Cortical and Cancellous Screw Parameters .....   | 23  |
| Table 2: Advantages and Disadvantages of the Rigid Cage, PMMA, Epoxy Putty, and Pulley-Pivot Fixture Systems ..... | 36  |
| Table 3: Pairwise Comparison Chart for Major Design Objectives for Bilateral Testing Method .....                  | 46  |
| Table 4: Functions to meet the prioritized objectives .....  | 48  |
| Table 5: Function-Means Analysis of Alternative Designs .....  | 62  |
| Table 6: List of Hypotheses and the respective number of different groups tested .....                             | 67  |
| Table 7: Power Analysis for all Hypotheses at 50% power .....  | 69  |
| Table 8 Total number of samples required based on power analysis .....   | 70  |
| Table 9: Average Bone Separation Data for unicortical vs. bicortical configurations .....                          | 116 |
| Table 10: Percent screw loosening data for unicortical vs. bicortical configurations .....                         | 117 |
| Table 11: Comparison of unicortical vs. bicortical configurations from cadaveric testing .....                     | 119 |
| Table 12: Average Bone Separation Data for different major diameter screws .....                                   | 121 |
| Table 13: Percent screw loosening data for different major diameter screws .....                                   | 122 |
| Table 14: Average Bone Separation Data for different fixation systems .....  | 123 |
| Table 15: Average screw loosening data for different fixation systems .....  | 124 |
| Table 16: Comparison of bone separation data for the Working Model 2D simulation .....                             | 128 |
| Table 17: Comparison of rod tension data for the Working Model 2D simulation .....                                 | 130 |

In 2005, nearly 900,000 people in the United States died from cardiovascular disease. Additionally, in 2006, 700,000 open-heart surgeries were performed to prevent this same fate in the 80 million people living with one or more forms of cardiovascular disease (American Heart Association, 2006.). Open-heart surgery requires bisection of the sternum, called a median sternotomy, in order to gain access to the heart. After the operation is completed the sternum must be closed using a fixation device.

Complications can occur as a result of sternal fixation. For example, if the fixation method does not minimize sternal separation, less than 2mm, then the sternum halves will not be close enough to foster bony ingrowth. Additionally, motion between the halves can result in mediastinitis, which is an inflammation of the tissues surrounding the sternum and vital organs. Up to 2.9% of open-heart patients are diagnosed with mediastinitis post operation (Lepelletier et al, 2009).

Traditionally, surgical steel cerclage wires have been used to close the sternum; however, these wires can damage and weaken the sternum in osteoporotic patients because the wires cut into the bone. Osteoporosis occurs in nearly 20% of women and 12% of men over 50 (American Heart Association, 2009), and about fifty percent of patients that have open-heart surgery are above the age of 65 (American Heart Association, 2008). This means that many open-heart surgery patients are likely to have some degree of osteoporosis or osteopenia. A rigid sternal fixation device using plates and screws could be more effective and beneficial in osteoporotic patients than traditional cerclage wires.

Rigid fixation systems have been used on long bones such as the femur and humerus, smaller bones such as those in the hands and feet, as well as the spine and jaw. These systems date back to the late 1880s, but their popularity increased greatly in the 1940s causing an increase in research (Bagby, 1977). As a result of this research, significant advancements have been made to improve plate and screw systems through evaluation of the three interfaces that comprise them: bone/screw, bone/plate, and screw/plate. The bone/screw interface has improved by determining the best types of screws, either cortical or cancellous, for certain bone types, while screw/plate advances have worked to minimize wobbling through consideration of different types of screw heads. The most recent research in rigid fixation development, however, has been towards improving the bone/plate interface by considering different topographies in order to increase rigidity while promoting bone regrowth.

While several advancements have been made regarding rigid fixation systems for a variety of bone types in the body, little research has been conducted specifically for the sternum. The use of these systems as a method to close the sternum post-sternotomy is still a novel concept, and therefore their advancement has been limited. Most research to improve plate and screw systems for the sternum has evaluated the number of plates to use, different plate shapes, and various plate configurations. Minimal research, if any, has been towards the improvement of the bone/screw, bone/plate, and screw-plate interfaces.

The ultimate goal of this project is to design a bilateral plate and screw system that minimizes anterior displacement and posterior splay of a bisected sternum by achieving the following goals:

1. Develop an *in vitro* system that measures plate displacement and bone splay in a bilateral sternotomy model
2. Use this system to complete quantitative analyses to evaluate the effects of cortical bone screws and anti-wobble systems on plate displacement, bone/plate interfaces, and posterior splay

We sought to achieve these goals by first designing a testing device that simulates *in vivo* breathing forces by performing bilateral cyclic testing on bisected sterna. This testing device was designed by considering experimental methods used in literature as well as brainstorming our own methods. It was then used to analyze the ability of various cortical screws and plates to minimize sternal dehiscence, posterior splay, and screw loosening. The types of plates and screws that were used were selected based on their different attributes regarding the three interfaces. Unicortical and bicortical screw configurations, various screw diameters, as well as locking, non-locking, and standard plates were all evaluated. Limitations of the final bilateral cyclic testing device were identified and future research was recommended in order to further the field of rigid sternal fixation systems.



## CHAPTER 2. BACKGROUND

### 2.1 CLINICAL NEED STATISTICS

Heart disease is the leading cause of death in the United States and continues to be a growing problem. Between 1996 and 2006, the number of cardiovascular procedures performed increased by thirty percent (American Heart Association, 2006). In addition, the number of open heart procedures performed rose from approximately 300,000 procedures in 1985 to almost 700,000 in 2006 (American Heart Association, 2006; American Heart Association, 2009). The patient populations for these types of surgeries are consistently elderly males over 65 (American Heart Association, 2009).

Due to the primary age group for open heart procedures, other medical considerations need to be taken into account. Osteoporosis and other bone diseases that may compromise the structural integrity of the patient's bone need to be addressed. Currently in the United States, approximately two million men and eight million women have been diagnosed with osteoporosis and many others are at risk or undiagnosed (National Osteoporosis Foundation, 2009).

In order to perform any open heart surgery, a midline sternotomy is required. This is a procedure where the surgeons create a vertical incision through the sternum using a bone saw (Kun, 2009). The sternum halves are then separated in order to gain access to the thoracic cavity and the heart. Currently upon the conclusion of the heart procedure, the bisected sternum halves are reunited and closed using surgical steel cerclage wires. Various complications can arise with this type of procedure and closure (Kun, 2009).

Between one and five percent of patients who undergo a median sternotomy experience some kind of complication (Voss, 2008). The mortality rate ranges from 14-47 percent

dependent on the type of complication (Martinez, 2005). One of the most common complications is from mediastinitis which is an infection of the tissues surrounding and between the lungs (national lib of medicine). Sternal instability is another problem often experienced when cerclage wires are used (Voss, 2008). This can lead to other problems like bone damage and stress which can be detrimental for the patient.

It is important to understand the vast population that undergoes open heart procedures and the complications that arise from them each year. Every one of these patients must have a median sternotomy. Since many of these patients are elderly, they have osteoporosis, or the less severe osteopenia, which is a weakening of the bone. Cerclage wires, the gold standard of sternotomy closures, can cut into the bone during respiration causing immense pain, infection, and create the need for additional surgeries. The goal is to minimize the amount of complications that arise from having a median sternotomy so patients have faster recovery free of infections and additional surgeries.

## 2.2 HUMAN STERNUM ANATOMY AND PHYSIOLOGY

The human sternum, also known as the breast bone, creates the anterior portion of the thoracic skeleton and attaches to the ribs which encapsulate the region containing the heart and lungs (Grey, 1918). The sternum density is variable throughout, changing from hard bone tissue to cartilage to allow for elasticity where needed for respiration activities (Selthofer, 2006).

The sternum is comprised of three separate sections, called sternebrae, before fusing during development to form one rigid bone (Grey, 1918). An image of human sternum can be seen in Figure 1. The manubrium is the superior portion of the sternum which is usually quadrangular in shape and supports the clavicles (Selthofer, 2006). The manubrium is the

thickest and most dense section of the sternum. Beneath the manubrium, the body of the sternum is connected and is much longer, narrower, and thinner than the manubrium (Selthofer, 2006). The body is most narrow where it joins the manubrium but then widens in the center and again narrows at its end (Grey, 1918). This body is where ribs two through seven attach to the sternum. Following the body, the xiphoid process is fused (Grey, 1918). The xiphoid begins highly cartilaginous and only ossifies around the age of forty (Grey, 1918). The xiphoid is the most variable region in terms of size and shape (Grey, 1918). Adult sterna are on average 17 cm in length but tend to be shorter in women (Grey, 1918). The average width of the body of a human sternum is 2.71 cm for women and 3.07 cm for men (Selthofer, 2006). Additionally, the average thickness of the body is 0.92 cm for women and 1.0cm for men (Selthofer, 2006).

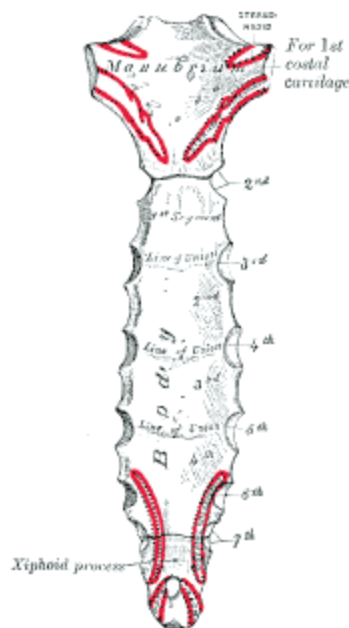

Figure 1: Adult Sternum Anatomy (Grey, 1918) Copyright Pending

The sternum is comprised of two types of bone, cortical and cancellous. The cancellous bone forms the interior of the sternum with the cortical bone serving as a hard shell around the cancellous layer (Grey, 1918). Cortical bone is very dense and gives bones their shape,

structure, and ability to withstand loading. Cancellous bone is a spongy, porous layer of bone, which is quite soft and serves to supply the outer bone with nutrients from the blood. Cancellous bone also contains the bone marrow, which is necessary in creating new blood cells. Since the sternum needs to be more elastic than other bone due to respiration, there is a higher concentration of cancellous bone with a relatively thin layer of cortical bone underneath (Grey, 1918). Another consideration about sternum anatomy is its curvature across sternal halves as it connects to the ribs.

In understanding the morphology of the sternum, now we can relate it to the other systems acting in the body. Throughout respiration, many muscles act within the thorax where the ribcage and sternum reside. The major muscle involved in inspiration is the diaphragm, which is a thin, flat muscle which separates the thoracic cavity and the abdominal wall (Ratnovsky, 2008). Other important inspiration muscles include the external intercostals, the sternomastoid, and scalene muscles also act during inspiration (Ratnovsky, 2008). The sternomastoid and the scalene muscles lift the sternum and first two ribs during inspiration, which aids in expanding the ribcage (Ratnovsky, 2008). In expiration, the interior intercostals, the four abdominal muscle pairs, the external and internal oblique, and the transverse abdominis (Ratnovsky, 2008). None of these muscles act specifically on the sternum, though they do act in compressing the ribs and lungs when the abdominal muscles are contracted.

The musculoskeletal systems that affect the sternum need to be understood when developing medical devices that will be used in these areas. By understanding the size variations of sternums throughout the human population, properly sized devices can be made for them. Also, the shape morphology of the bone must be considered so that any devices created will fit.

Bone layers are important in this model in any orthopedic application. The cortical layers are quite strong, but only cover the very surface of the bone. The cancellous bone layers are soft and moldable which may cause problems when affixing devices to the bone here. Additionally, the forces which act on the sternum during respiration can be used to create a breathing model to test newly developed devices.

## 2.3 BIOLOGICAL FACTORS WITH RIGID FIXATION

### 2.3.1 STRAIN THEORY

The amount of strain exerted on the sternum needs to be considered in order to keep the sternum halves in union to stimulate healing. The amount of strain determines the type of healing and the speed of the healing process. Strain theory states that the amount of strain on the bone determines the type of healing that will occur at a fracture site. A strain of 2% or less induces primary healing because the fracture site exhibits absolute stability. Primary healing is direct healing between the fractured bones. A strain between 2% and 10% results in secondary bone healing which results in callus formation at the fracture site (Egol, 2004). Secondary healing occurs when pluripotent mesenchymal stem cells differentiate into cartilage and eventually ossify into bone within a fracture site. These stem cells reside beneath the periosteum, which is the connective tissue covering the bone (Malizos, 2005). Finally, a strain above 10% results in non-union and no healing occurs. The ultimate goal of rigid fixation is to induce primary or secondary healing in order for union and regrowth at the fracture site (Egol, 2004). With the amount of strain in mind, the design of the screw and plate implanted into the sternum halves must adhere to the strain theory to stimulate healing and avoid non-union. Therefore the change in distance may not exceed a certain amount to simulate over 10% strain.

## 2.4 SCREW CHARACTERISTICS

Screws are mechanical structures designed to convert torque into compressive force between the objects that they connect. (Chapman, 1996) There are two major types of screws that can be used in bone – cortical and cancellous based on the type of bone into which they are inserted (Figure 2).

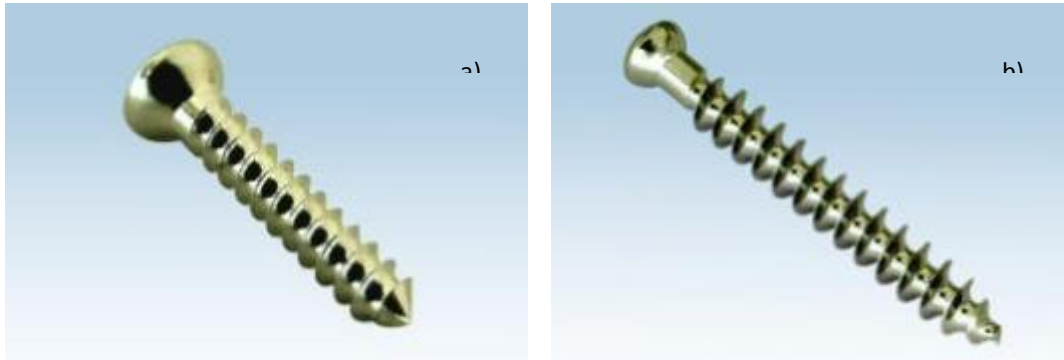

Figure 2: a) Cortical Screw, b) Cancellous Screw (Crown Metal Works, 2009)

Cortical screws are characterized with small thread depth and pitch, but also by a high number of threads per unit length (reference Figure 3 for general screw characteristics). These properties provide the cortical screws with high holding power in hard bone, such as cortical bone. In contrast, the cancellous screws have large thread depth, which provides more surface contact with the threads. Cancellous screws have a low thread count because they have large pitch. Cancellous screws are intended to be used in porous bone such as bone structure with a thin cortical layer and a predominantly cancellous layer (Shields, 2004). Table 1 is summarizing the differences in the three most important parameters of cortical and cancellous screws.

Table 1 Comparison of Cortical and Cancellous Screw Parameters

| Parameters   | Cortical screw | Cancellous screw |
|--------------|----------------|------------------|
| Thread depth | Small          | Large            |
| Pitch        | Small          | Large            |
| Thread count | Large          | Small            |

Various factors might have an impact on bone purchase, but the most important ones are bone density, bone condition (healthy or osteoporotic), and bone shape and curvature. It has been found that cortical screws have better bone purchase in axial loading than cancellous screws. They also provide higher stability when subjected to cyclic loading (Ahn, 2009). Based on the results from previous research (Ahn, 2009) our project will be focusing on cortical screws only.

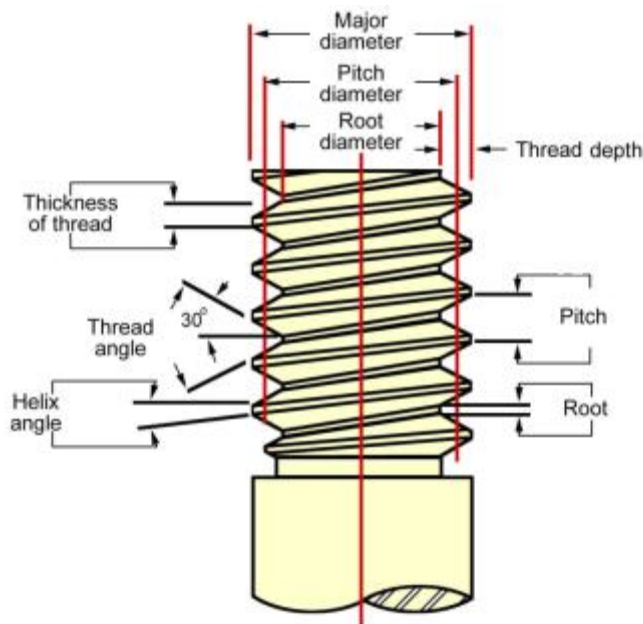

Figure 3: Pictorial Demonstration of Various Screw Characteristics (Medscape, 2009) Requesting Copyright permission.

It is crucial to consider screw performance during cyclic testing because the sternum is constantly subjected to static or dynamic motion due to the function of the respiratory system.

Researchers have found that lateral forces have 4.5 times higher magnitudes (43.8 N) than the forces in transverse (9 N) or longitudinal direction (10N) (Pai, 2008). It has also been reported that the lateral forces dominate in magnitude over the shear forces in a porcine sternotomy model (J. Losanoff, 2004) but they are still in the same order of magnitude (Pai, 2008). Given this information our testing plan will be focused only on applying forces in lateral direction.

## 2.5 UNICORTICAL AND BICORTICAL CONFIGURATIONS

Unicortical and bicortical configurations are two ways rigid fixation systems can be applied. As seen in Figure 4, the sternum bone consists of a top cortical layer, a low density cancellous layer, and a bottom cortical layer. Unicortical configurations only pass through the initial cortical layer whereas bicortical configuration pierces through the first and into or through the second cortical layer of the bone, as seen in Figure 4.

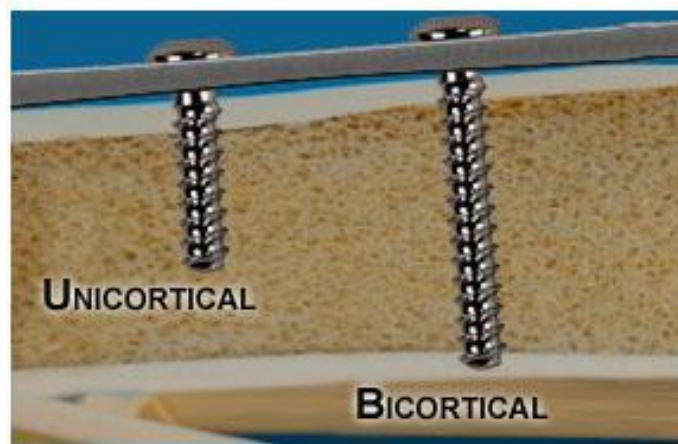

Figure 4: A side view of unicortical and bicortical screws within the sternum

It is believed that bicortical configuration exhibits greater stability because it allows the screw to purchase into both cortical layers. Though bicortical configuration is thought to be more stable, it also has several potential drawbacks. If the screw does not pierce through the second cortical layer it may push the second cortical layer creating an empty space between the



second cortical layer and cancellous layer. If the screw pierces the second cortical layer there is also a possibility of the second cortical layer being pulled in causing a concave shape compressing the cancellous layer. Both scenarios can damage the bone and are seen in Figure 5.

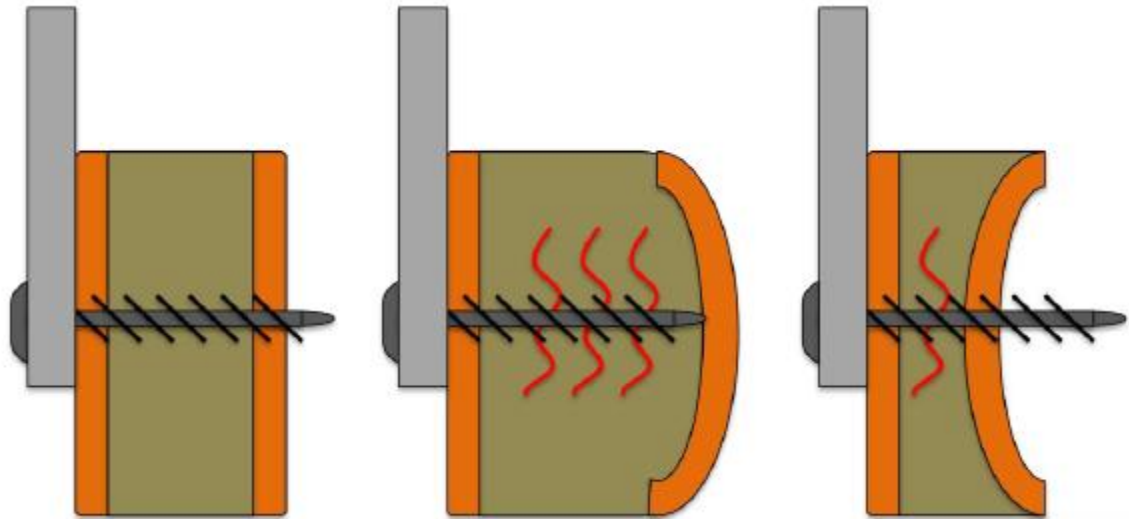

Figure 5: Failure scenarios using bicortical configurations (Ahn, 2009)

## 2.6 PLATE CHARACTERISTICS

### 2.6.1 DISTANCE BETWEEN BONE AND PLATE

While dynamic compression plates (DCP) are flush to the bone, locked compression plates (LCP) give variable clearance between the plate and the bone. By providing a small space between the bone and plate, the periosteum is preserved and does not become stripped. The periosteum is crucial for bone healing and remodeling, and stripping the periosteum layer off the bone tissue will result in bone necrosis and slower healing rates. Studies using polyurethane sawbone modeling diaphyseal fracture showed that in load to failure and rotational deformity tests resulted in similar mechanical properties within 0 mm to 2 mm spaced plates by analyzing

the load to failure values, deformity and displacement (seen in Figure 6). Overall the preferred distance for the best rigidity and bone healing is 2 mm or less from the plate (Ahmad, 2007).

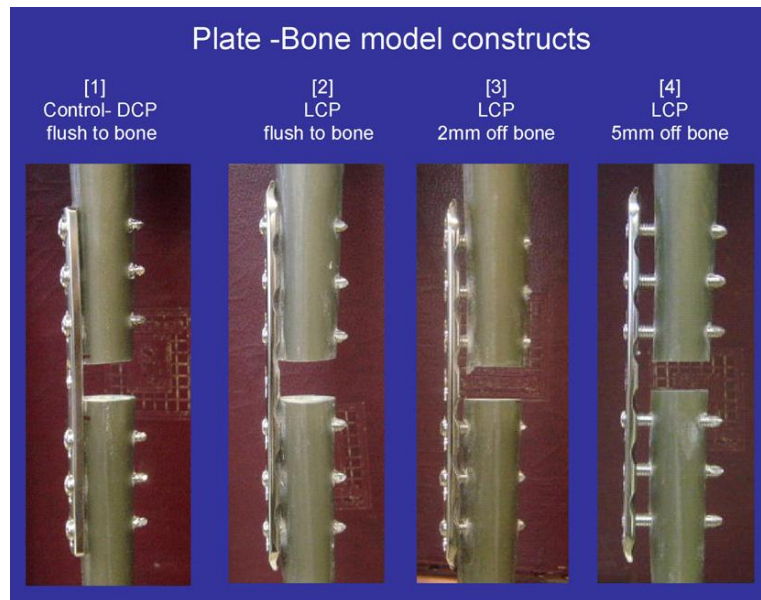

Figure 6: Plate spacing configurations for testing – DCP (Dynamic Compression Plates) and LCP (Locked Compression Plates) (Ahmad, 2007) (Copyright pending)

## 2.7 PLATE DESIGN

Due to the variety of different bone sizes and shapes, there have been many plate designs to accommodate and bolster mechanical stability and biological factors. Plate design considerations include diverse shapes, sizes, topographies, screw variations, and locking capabilities.

Various designs implemented into diaphyseal fracture internal fixation plates can be considered for a superior design for sternum plates. The topography, geometry, and locking mechanism of the plates change the force distribution, amount of pressure on the sternum, and forces exerted on the screw and plate.

---

### 2.7.1 STRAIGHT PLATES

The first traditional compression plate and screw system was introduced in the late 1950s to induce rigid internal fixation on diaphyseal fractures. (Greiwe, 2007) Although standard compression plates were the gold standard for diaphyseal fractures there have been several plate design advancements implemented to improve quality of life for patients. One of the main advancements includes a locking mechanism between a plate and the head of a screw. By employing a threaded head locked into a threaded hole, angulation and axial stability are improved. Locked plates have become highly advantageous to osteoporotic bone and highly comminuted fractures.

The dynamic compression plate (DCP), seen in Figure 7, is a straight plate with no locking mechanism that is flush directly to the bone. DCPs are designed to produce absolute stability within the fracture site, promoting primary healing. This design does not use a locking screw, allowing screw angle to be varied. Though this seems beneficial, there are several concerns when using DCP in osteoporotic bone. Because the DCP loads flush to the bone the tension and compression forces are converted to shear stress between the bone and screw (Zehnder, 2009). Due to the porosity of osteoporotic bone, the shear stress exerted between the screw and bone results in pullout failure. In addition, concerns regarding DCP-bone contact exist because this can interfere with the healing process (Egol, 2004).

The low contact- dynamic compression plate (LC-DCP), seen in Figure 7, modified the DCP to biologically improve the fixation system by changing the topography. The LC-DCP plating design is still flush to the bone; however its topography and screw hold design has been altered from the DCP. The topography has a uniform cut at the bottom of the plate which reduces

surface contact between the plate and bone allowing for better bone growth. The screw hole is expanded to give the user variability for angulation of the screw.

PC-Fix, as seen in Figure 7, combines locked plating technology with a change in topography design. The locked plating has threads along the inside of the hole that allows fixture between the screw head and the plate. This allows for separation between the plate and the bone, optimizing fracture healing, but does not allow for screw angulation (Ahmad, 2007). The locking mechanism does not depend on the shear stress between the threads of the screw and the bone therefore is recommended in osteoporotic bone (Zehnder, 2009) (Greiwe, 2007). The shear stress typically seen in the DCP and LC-DCP is converted into compression stress. The topography of the PC-fix plate is wavy in order to preserve the tissue surrounding the bone. Studies in clinical and experimental models have shown that infection rates after surgery are significantly lower for LC-DCP and PC-Fix compared to the DCP because of the limited bone/plate contact (Eijer, 2001).

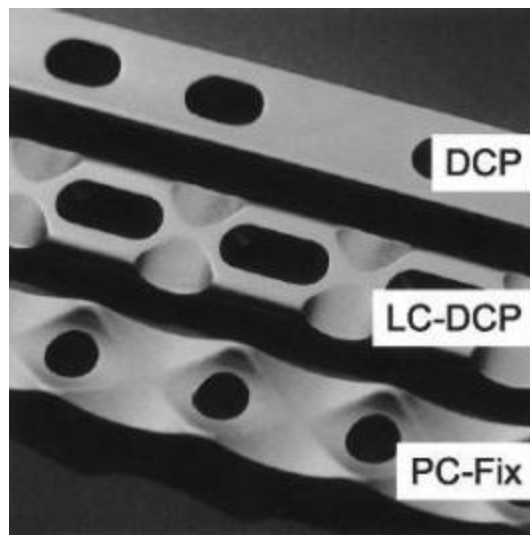

Figure 7: Three types of plates (Dynamic Compression plate (DCP), low contact- dynamic compression plate (LC-DCP), and low contact locking plate (PC-Fix) demonstrating screw hole variability and topography (Shutz, 2003) (Copyright pending)

Figure 8 shows a hybrid screw-plate design that gives variability of screw orientation and screw types that can be used with the plate. This variability gives the benefit of being able to use locked screws and non-locking screws as well as the benefits of a low-contact plate (Gardner, 2006). The design also gives the option of angulation with the amount of space in the plate.

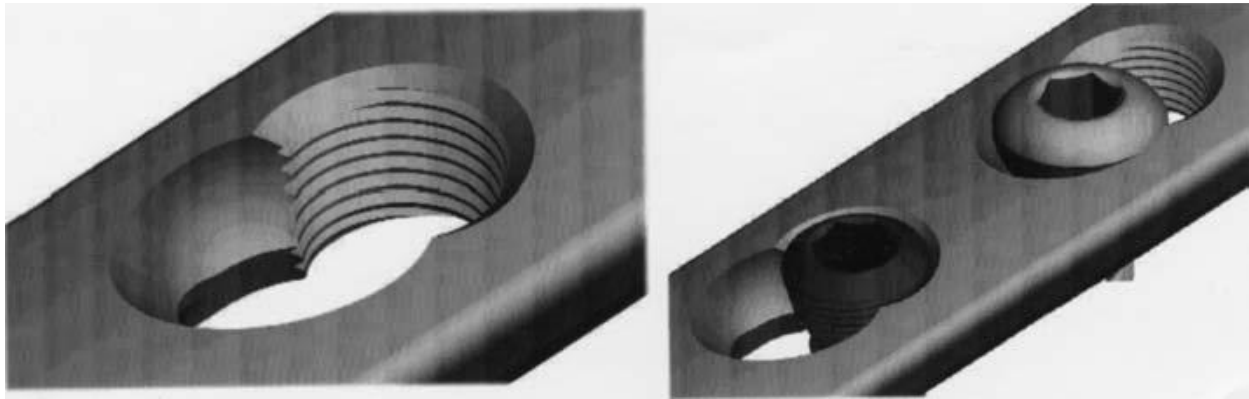

Figure 8: A close up view of the Hybrid Screw Design on the left and a view of how each screw can be utilized on the right (Shutz, 2003)  
(Copyright pending)

---

### 2.7.2 STERNUM PLATES

Many complications, risk factors, and constraints make median sternotomy closure devices difficult to design, particularly for rigid fixation systems. An important consideration for this kind of design is that the parts of the device, such as the screws, do not protrude from the interior of the sternum. These protrusions can damage the vital organs that are protected by the sternum. Additionally, the device must allow the surgeon to retrieve any component and re-entry in the sternum for future procedures. Despite these risks, a screw-plate system is important to consider for patients with high risk factors or who cannot use cerclage wires (Ozaki, 1998).

### 2.7.3 X-PLATES AND H-PLATES

As seen in Figure 9 and Figure 10, the X-plate and H-plate are designed to fit the geometry of the sternum (D.H Song, 2004). By using the H-Plate and X-plate configurations, the screws are placed furthest away from the sternotomy cut giving it superior placement at the thicker, denser location of the bone. Poorly placed screws in the sternum too close to the fracture site develop small bone fractures near the midline sternotomy. The use of straight plates does not give the option of screw orientation but instead is limited to a straight configuration. Uniaxial compression testing comparison has proven that H-plates have significantly higher stiffness and lower rates of displacements and failures compared to cerclage wires (Ozaki, 1998).

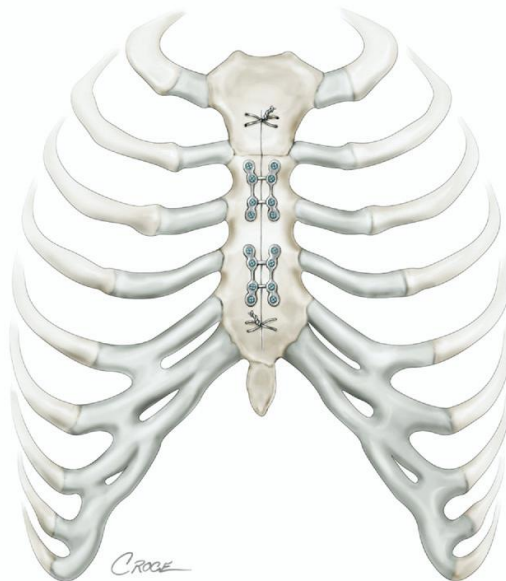

Figure 9: X-plate use in Sternum Closure (Raman, 2007) (Copyright pending)



Figure 10: Custom made H-plate from KLS-Martin L.P. (Ozaki, 1998) (Copyright pending)

---

#### 2.7.4 PLATE MECHANICS

The plate topography and contact areas are factors that determine the bone-plate mechanical properties. It has been reported that the contact area of long bone is reported to be between 11% and 22% which is crucial in preserving the periosteum layer of the bone. Plates in compression, screw torque and the radius of curvature are factors for average forces and contact points between DCP and LC-DCP. It has been shown that screw torque has a major factor in the contact area and the average force loaded onto the model. As screw torque has increased the amount of contact area covered and the amount of forces exhibited on the model increased. When increasing the radius of curvature of the plexiglass model showed a 50% increase of contact area and an increase on average forces on the system. (Field, 1998)

## 2.8 FIXTURES TO TEST FIXATION SYSTEMS

Researchers have used a variety of methods in order to test sternal closure devices. Some require full cadaver testing, while others require the use of whole or partial sternum. An advantage of full cadaver testing is that the sternum is intact and can best mimic *in vivo* circumstances without using live participants. Whole sternum testing is conducted on sternum that has been removed from a cadaver. Similar to full cadaver testing, an advantage to whole sternum testing is that using an entire sternum can show results that reflect more similarly to what actually happens *in vivo*. Partial sternum testing usually involves testing on individual rib pairs and can allow for larger sample sizes because more tests can be performed per sternum. Cadaveric tissue is extremely expensive, upwards of \$1,500 per sternum, which is why partial sternum testing is commonly used. For this reason, researchers tend to use bone models, such as polyurethane sawbone, in order to perform preliminary tests and minimize cost.

An example of full cadaver testing was conducted by McGregor, Trumble, and Magovern in 1999 seen in Figure 11. They constructed a customized rigid cage out of steel piping. This cage was placed around the chest of the cadaver. Brass plates were fixed to the tops of the rib struts close to the sternotomy line. A cable was attached to each brass plate, and then each cable was joined together with an o-ring, and then connected to the rigid cage. A load cell was attached on one side of the cables in order to apply forces to the sternum. This setup could be altered to apply force in the three directions: lateral, anterior-posterior, and rostral-caudal (McGregor, Trumble, & Magovern, 1999). The rigid cage method as well as a diagram of the three possible testing directions can be seen in Figure 11 and Figure 12.



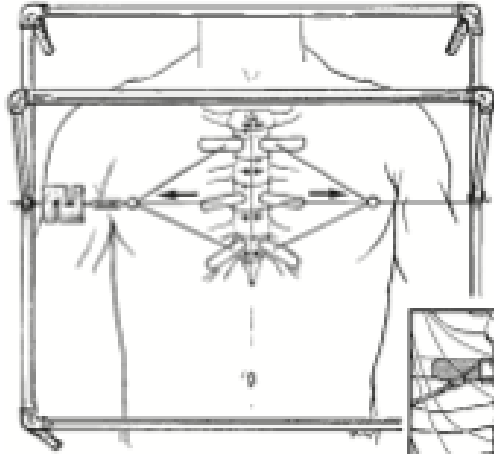

Figure 11: Rigid Cage Testing Method (McGregor, Trumble, & Magovern, 1999)

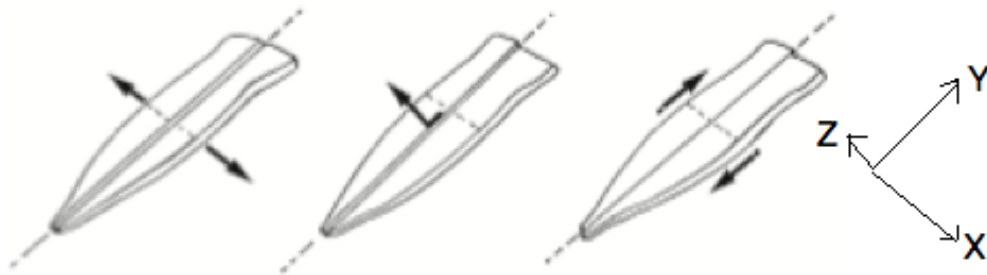

Figure 12: Three Testing Directions: *left*, lateral [X-direction]; *center*, anterior-posterior [Y-direction]; *right*, rostral-caudal [Z-direction] (McGregor, Trumble, & Magovern, 1999)

While McGregor, Trumble, and Magovern’s method can test in three directions, researchers agree that lateral forces are the most important to study. Lateral forces have the greatest magnitude during *in vivo* breathing (Pai et al., 2008). Additionally, researchers agree that cyclic fatigue testing, testing that performs a repetitive cyclic motion that simulates wear on a material over an extended length of time in order to determine the material’s strength and durability over time, should be used in order to test sternal closure devices as it is most representative of forces during *in vivo* breathing (Cohen & Griffin, 2002; Pai et al., 2008). Prior

research recommends that 15,000 cycles should be performed at a frequency of 2Hz applying a force up to 50N per cycle to conduct cyclic fatigue testing on sternum (Pai et al., 2008). In order to perform this type of testing, grips must be designed to attach the sternum to a cyclic testing machine. In our research, we discovered three general methods that have been used to grip the sternum for testing.

Two of these methods are fairly similar because they use glue-like substances to fixate the sternum into a cup or box. Cohen and Griffin used polymethylmethacrylate (PMMA) to fixate the bone into an aluminum casing. The grips were reusable because the PMMA could be separated from the aluminum casing post-testing. Additionally, Cohen and Griffin designed three different grips that the casing could attach to test in the three force directions (Cohen & Griffin, 2002). This gripping method can be seen in Figure 13.

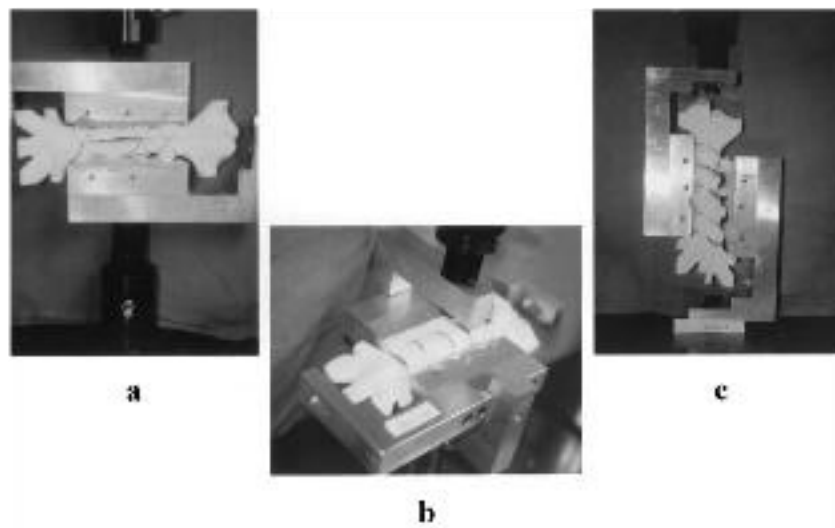

Figure 13: PMMA and Aluminum Casing Grip: *a.* testing in the lateral direction, *b.* testing in the anterior-posterior direction, *c.* testing in the rostral-caudal direction (Cohen & Griffin, 1999)

Another gripping method that is similar to Cohen and Griffin's was used by Decoteau et al. in 2006, and by Ahn et al. in 2009. In both cases, the researchers used epoxy putty to grip

the bone in polyvinyl chloride (PVC) caps. Unlike the PMMA grips, these grips were only designed to apply lateral forces and were not reusable because the putty cannot be removed from the PVC caps (Ahn et al., 2009; Decoteau et al., 2006). A drawing of the grips used by Decoteau et al. can be seen in Figure 14.

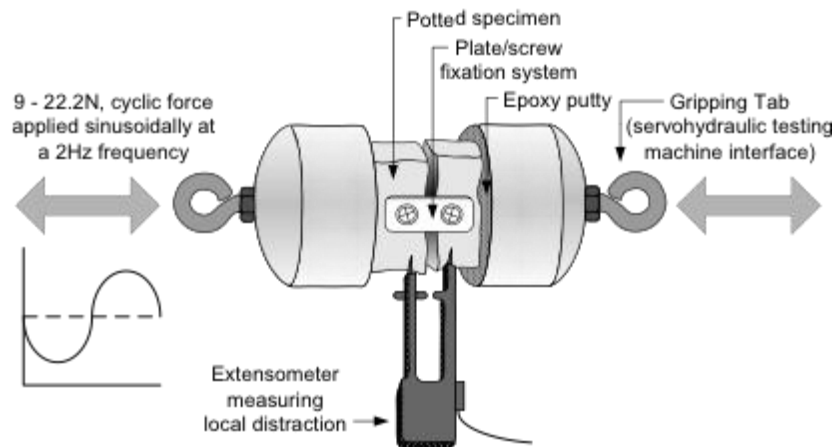

Figure 14: Epoxy Putty and PVC Cap Grip (Decoteau et al., 2006)

The final gripping method we discovered during our research was a tethering system designed by Pai et al. in 2005. Circular pivots and wire were used as a pulley system and attached the sternum to a grip fixated to the cyclic testing machine through small holes at each rib strut. Pai et al.'s method was designed specifically to control the lateral force distribution across the entire sternum and applied a maximum load of 50 N per cycle (Pai et al., 2005). This pulley-pivot gripping system can be seen in Figure 15.



Figure 15: Tethering Gripping System Made of Pulleys and Pivots (Pai et al., 2005)

Several methods have been used to test sternal closure methods, and some of these systems have been used on whole cadavers while others fixate whole or partial sternum to a cyclic testing machine. Each method has its own advantages and disadvantages, but all of them have been used to successfully evaluate sternal closure devices. Table 2 summarizes the advantages and disadvantages of the four fixture systems described above.

Table 2: Advantages and Disadvantages of the Rigid Cage, PMMA, Epoxy Putty, and Pulley-Pivot Fixture Systems

| Method       | Cyclic Fatigue | 3-Directional | Cough Simulation | Whole Sternum Testing | Controlled Force Distribution | Reusable Fixture | Inexpensive |
|--------------|----------------|---------------|------------------|-----------------------|-------------------------------|------------------|-------------|
| Rigid Cage   | X              | X             | X                | X                     | X                             | X                |             |
| PMMA         | X              | X             |                  | X                     |                               | X                |             |
| Epoxy Putty  | X              |               |                  |                       |                               |                  | X           |
| Pulley-Pivot | X              |               |                  | X                     | X                             | X                | X           |

## 2.9. MATHEMATICAL MODELING

### 2.9.1 MATHEMATICAL EQUATIONS

One of the major mechanisms of failure is the progressive screw loosening resulting from the screw-bone interaction (Ahn, 2009). To ensure proper healing this issue has to be analyzed and taken into consideration in order to improve current sternal fixation systems. An effective way of measuring screw loosening is by measuring the screw hole volume before and after the test. Chapman et al. described a method to determine that volume by making a cast of the screw hole volume made in polyurethane sample. The specific densities used in the research were: low density (0.16 g/cm<sup>3</sup>), medium density (0.24 g/cm<sup>3</sup>), and high density (0.32 g/cm<sup>3</sup>). The material used for casting was a high density and low melting point alloy. The procedure included weight measurement of the sample with and without the casting material. For calculation purposes the researchers used a mathematical equation to find the volume based on those measurements (Chapman et al, 1996).

$$V = \frac{W_c - W_o}{\rho}, \text{ where:}$$

V= volume

$\rho$  = density of casting material

$W_c$  = weight of foam specimen with casting material

$W_o$  = weight of foam specimen after hole preparation but without casting material

It was reported that the polyurethane samples were designed to shrink by less than 1% upon heating at 120°C. Given that the alloy has a melting point of 70°C it was not likely to expect foam material deformation when pouring the molten alloy into the screw holes. In order

to calculate the volume of the hole, the mass of the polyurethane block was measured before casting the hole and after casting the hole.

In order to perform verification of the formula a parallel experiment was performed by emersion of the polyurethane foam block with the drilled screw hole in water. The volume of the hole was determined by observing the change of the water level in a graduated cylinder (Chapman et al, 1996).

---

### 2.9.2 MATHEMATICAL MODELS

Novel techniques for quantitative analysis of biomechanical structures involve the use of software to model the system of interest. The development of computational models of complex biomechanical processes is motivated by medical and economical considerations. Engineers collaborate with medical specialists to investigate ways to build effective and accurate computational models that would facilitate research activities. The model needs to be validated by performing identical experiments with the model and with the biological system of interest. Once validated, this tool can be used for further predictions of the behavior of new devices or systems. A particular area of interest for this particular project is placed on force distribution in lateral loading of sternum and the total displacement of the two sterna halves as a result of the applied load. Several techniques have been developed in order to facilitate the modeling activities. One of the most complex ones is the Finite Element Analysis (FEA) method using ANSYS software. It provides a three-dimensional (3D) model based on computer tomographic scanned pictures of the entire human chest. A number of pictures are taken at 2.5-mm segments that are analyzed individually in order to distinguish the different bone structures (sternum, ribs, cartilage). This information is then embedded into the model (Figure 13) by assigning different

material properties to each structure. The model was focusing on measurement of sternal separation for simple cerclage wire fixation and a figure-of-eight fixation techniques. The results reported by the authors show that there is stress concentration at the locations of contact between bone and wire (light blue and green color in Figure 16). They found the magnitude of stress to be  $20\text{N/mm}^2$  for both wire fixation techniques.

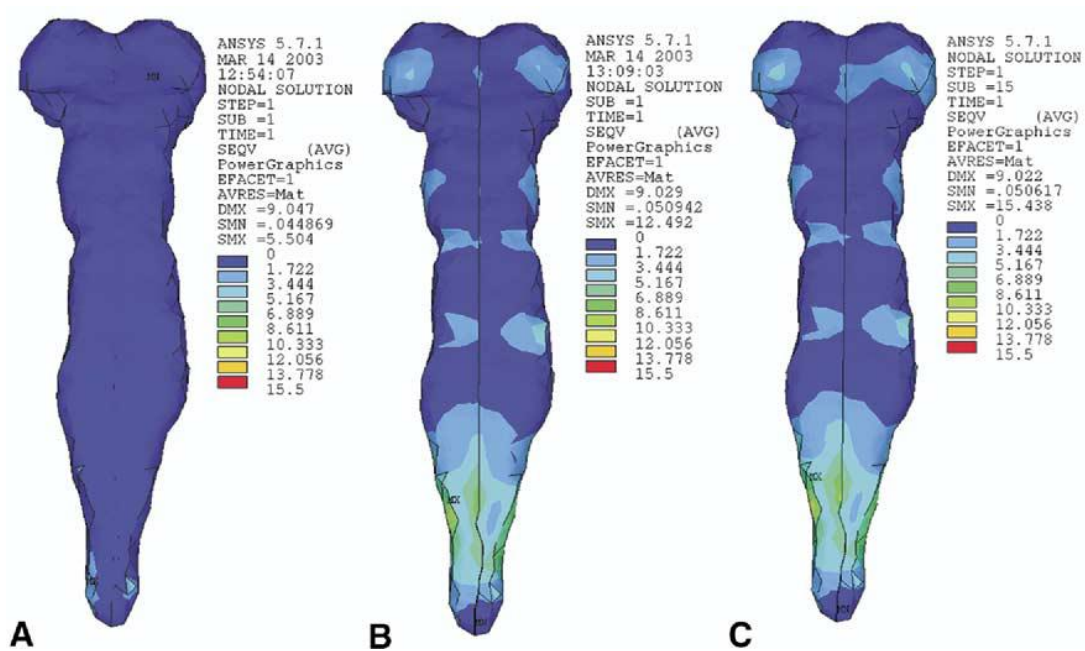

Figure 16: Illustration of (A) stress for intact sternum [N/mm<sup>2</sup>]; (B) stress for simple-wire loop [N/mm<sup>2</sup>]; and (C) stress for figure-of-eight loop [N/mm<sup>2</sup>]. Requesting copyright permission

The FEA model is suited for analysis of more complicated cases that are difficult to test, such as simulating leaning on one side as shown in Figure 16. In addition, the model can be used to simulate various closure techniques subjected to cyclic loading such as breathing. (Bruhin, 2005)

In general, mathematical models are based on known or measured values that are applied to a structure. Given that the living body is an extremely complex system it is necessary to make assumptions that simplify the problem yet still keep the essential concept.

In our project the goal will be to create an accurate representation of the sternum rib pair with its respective forces applied at the rib-sternal body connections (Pai, 2008). By performing bilateral cyclic testing we expect to modify the mathematical model so that it would have outputs with magnitude similar to the experimental data. Once this model has been validated by producing the same results as our experimental data, we would be able to use it to predict the outcomes of various situations. For example, we would be able to see if a sternal closure device would fail based on the position of the plate and the angle at which it was applied. Using the simulated model for further research can allow analysis of complicated systems and scenarios that are not possible to be tested in a lab setting. An example of such case could be the analysis of the loads on a fixation system when a person pulls themselves out of bed or twists the body without having to test the device on a living person. Therefore, computer simulations are useful for reducing testing time and bringing more variety and robustness to the mechanical analysis of sternal closure fixation techniques.



### 3.1 CLIENT STATEMENT AND DESIGN GOALS

In order to begin the design process, key stakeholders need to be identified for which the design is being made. The key stakeholders are the designers, clients, and users. The designers of this project are the Worcester Polytechnic Institute biomedical engineers. The clients of this project are the University of Massachusetts Medical School surgeons. The users of this project are the surgeons as well as the patients that the final device would ultimately be implanted into.

In order to understand the goals of this project, it is important to review the previous work that has been conducted prior to its conception. The start of the series of projects that led up to the client statement for this research began examining cortical versus cancellous screw types and their ability to improve rigidity of fixation devices in the sternum. Next, the screw/plate interface was primarily evaluated in unicortical configurations to improve system rigidity. Following the promising results of these studies, the clients requested further research to be conducted in bicortical configurations in order to statistically and clinically validate these findings.

---

#### 3.1.1 INITIAL CLIENT STATEMENT

Design and develop an in vitro model system that will evaluate the parameters of a bilateral screw and plate system, based on a preliminary design that minimizes the displacement of a bisected sternum post sternotomy.

---

### 3.1.2 LIST OF OBJECTIVES FOR BILATERAL TESTING METHOD

1. Ability to Grip Both Sterna Halves
2. Perform Cyclic Testing
3. Accuracy
4. Test Reproducibility
  - a. Measure Stability
  - b. Measure Displacement
    - i. Anterior Dehiscence
    - ii. Posterior Splay
5. Instrumentation Reproducibility
  - a. Control Force Distribution
  - b. Straight Sternotomy Line
  - c. Consistent Alignment of Sterna in Grips
  - d. Does Not Alter Mechanical Properties of Tissue
6. Cost Effective
7. Ease of Use
  - a. Few Components
  - b. Computerized Data Acquisition
8. Accommodate Multiple Tissue Samples
  - a. Multiple Rib Pairs
    - i. Size
    - ii. Shape
    - iii. Density
  - b. Multiple Types
    - i. Polyurethane Bone
    - ii. Fixed Cadaver Sterna
9. Time Efficient
  - a. Quick Prep
  - b. Quick Reset

### 3.1.3 OBJECTIVES TREE FOR BILATERAL TESTING METHOD

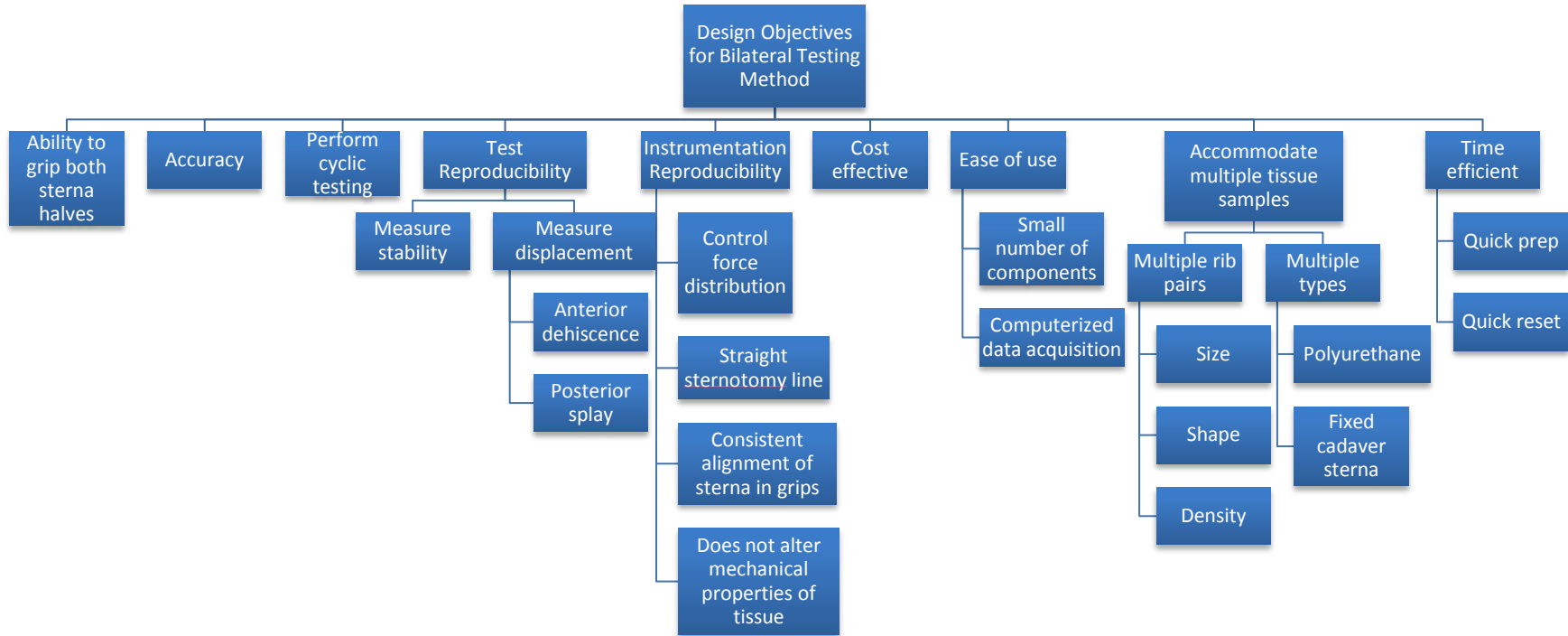

---

#### 3.1.4 FUNCTIONS FOR BILATERAL TESTING METHOD

##### Fixtures:

- Perform Bilateral Tensile Cyclic Testing
- Align Sternal Cut Parallel with Tops of Fixtures
  - Angle Grips with Instron
- Align Sternal Cut Angled with Tops of Grips
  - Fix Grips Perpendicular to Instron
- Align Sternum Parallel with Instron
- Able to Grip Both Sternal Halves
- Able to Grip Multiple Tissue Samples

##### Measurement:

- Measure Anterior Dehiscence
- Measure Posterior Splay
- Measure Screw Loosening
- Measure Medio-Lateral Displacement

---

#### 3.1.5 CONSTRAINTS FOR BILATERAL TESTING METHOD

- Precision > 0.01
- Time ~8 Months
- Budget ~\$624
- Safety/FDA standards
- Screw protrusion from posterior side = 0mm  $\pm$  0.001mm (Raman, 2007)
- Dehiscence between sternum halves < 1mm /half (Pai et al., 2005)
- Posterior splay < 2mm (Pai et al., 2005)

---

### 3.1.6 DESIGN SPECIFICATIONS FOR STERNAL CLOSURE TESTING DEVICE

- Anterior Dehiscence < 1mm/half (Pai et al., 2005)
- Posterior Splay < 2mm (Pai et al., 2005)
- Cyclic testing (Pai et al., 2005):
  - 2 Hz
  - 0-50N
  - 15,000 cycles
- Bone Model Types:
  - Polyurethane low-density bone
  - Fixed/fresh cadaveric sterna
- Lateral Testing
- Bone/Plate separation <2mm (Ahmad, 2007)
- Tissue wetting
- Forces of breathing (Ratnovsky, 2008):
  - External intercostal muscles ~107-242N
  - Internal intercostal muscles ~8-30N
- Elastic modulus of Sternum ~11.5GPa (Brown, 2000)
- Shear modulus of Bone ~ 4-5 MPa (Brown, 2000)
- Screw torque ~ 0.190647 N-m (Ahn et al., 2009)

### 3.2 EXPERIMENTAL DESIGN

We developed a series of pairwise comparison charts for all objectives, sub-objectives, and sub-sub-objectives for both the bilateral testing method and the rigid sternal closure device based on the final objectives lists for these goals. The University of Massachusetts Medical School (UMMS) Team with which we are working completed these charts in order to rank the priority of each objective, sub-objective, and sub-sub-objective. The major objective pairwise comparison charts can be found in the following sections, while all completed charts including the sub-objective and sub-sub-objective charts can be found in Appendices A-H.

### 3.2.1 PAIRWISE COMPARISON CHART FOR MAJOR DESIGN OBJECTIVES FOR BILATERAL TESTING METHOD

Table 3: Pairwise Comparison Chart for Major Design Objectives for Bilateral Testing Method

|                                     | Ability to Grip Both Sterna Halves | Perform Cyclic Testing | Measure Stiffness | Reproducibility | Cost Effective | Ease of Use | Accommodate Multiple Tissue Samples | Time Efficient | TOTAL Score |
|-------------------------------------|------------------------------------|------------------------|-------------------|-----------------|----------------|-------------|-------------------------------------|----------------|-------------|
| Ability to Grip Both Sterna Halves  | X                                  |                        |                   |                 |                |             |                                     |                |             |
| Perform Cyclic Testing              |                                    | X                      |                   |                 |                |             |                                     |                |             |
| Measure Stiffness                   |                                    |                        | X                 |                 |                |             |                                     |                |             |
| Reproducibility                     |                                    |                        |                   | X               |                |             |                                     |                |             |
| Cost Effective                      |                                    |                        |                   |                 | X              |             |                                     |                |             |
| Ease of Use                         |                                    |                        |                   |                 |                | X           |                                     |                |             |
| Accommodate Multiple Tissue Samples |                                    |                        |                   |                 |                |             | X                                   |                |             |
| Time Efficient                      |                                    |                        |                   |                 |                |             |                                     | X              |             |

### 3.2.2 NEEDS ANALYSIS

According to the results of the pairwise comparison charts, we ranked the objectives (seen in Figure 17) and performed a needs analysis in order to be able to develop design alternatives for our testing method.

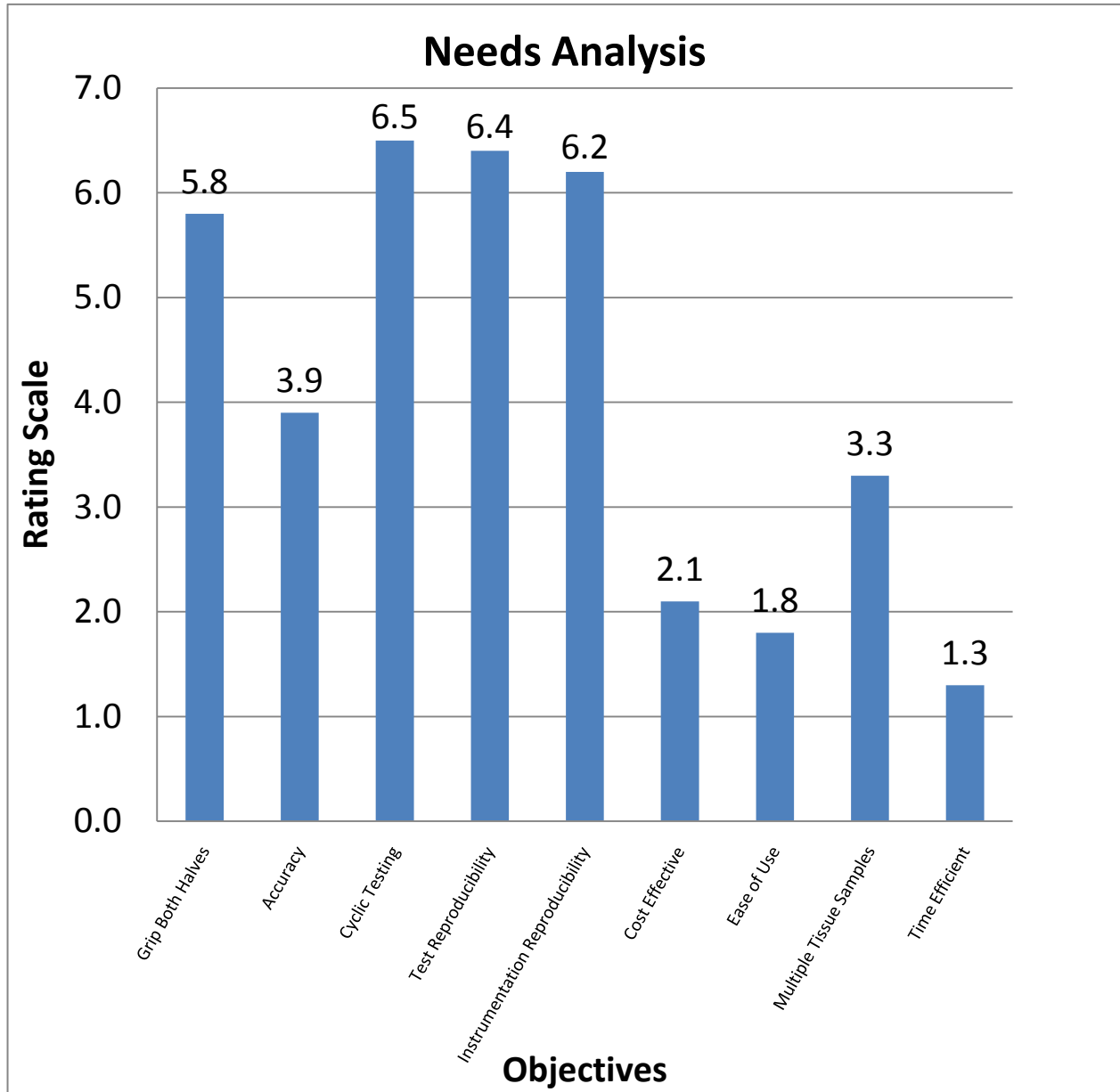

Figure 17: Numeric ranking of testing device objectives ranked by stakeholders and advisors

Using the prioritized ranked objectives the group then was able to list and evaluate functions of the testing device needed to complete each objective (seen in Table 4). The four highest ranked objectives were cyclic bilateral testing, test reproducibility, instrumentation reproducibility, and gripping both halves. We had focused on meeting the top four highest ranked objectives for our testing device.

Table 4: Functions to meet the prioritized objectives

| Objectives                             | Functions                                   |
|--|---|
| <b>Bilateral Cyclic Testing</b>        | Perform Bilateral Tensile Cyclic Testing    |
| <b>Test Reproducibility</b>            | Parallel Sternal Cut Alignment/Angled Grips |
|  | Angled Sternal Cut Alignment/Straight Grips |
|  | Parallel Sternal Alignment with Instron     |
| <b>Instrumentation Reproducibility</b> | Measure Anterior Dehiscence                 |
|  | Measure Posterior Splay                     |
|  | M/L Displacement                            |
| <b>Grip Both Halves</b>                | Able to Grip Both Sternal Halves            |
| <b>Accuracy</b>                        | -   |
| <b>Multiple Tissue Samples</b>         | Ability to Grip Multiple Tissue Samples     |
| <b>Cost Effective</b>                  | -   |
| <b>Easy to Use</b>                     | -   |
| <b>Time Efficient</b>                  | -   |

Each function was then listed to brainstorm procedures or methods to meet the objectives. We had collectively gathered information from either past experiences or present practices as possible uses for the testing device during the conceptual design phase.

---

### 3.2.3 REVISED CLIENT STATEMENT

Design and develop an in vitro model system that simulates in vivo breathing and will evaluate the rigidity of various bilateral screw and plate systems through the analysis of anterior dehiscence, posterior splay, and screw loosening based on a preliminary design that minimizes the anterior dehiscence and posterior splay of a bisected sternum post sternotomy to less than 2 mm. Then, design and optimize a bilateral screw and plating system that minimizes the anterior dehiscence and posterior splay of a bisected sternum that is easy to use, safe, marketable, durable, applicable for osteoporotic bone, and is aesthetically pleasing through the statistical comparison of several currently existing plate and screws systems by investigating the bone/screw, bone/plate, and screw/plate interfaces.



### 3.3 CONCEPTUAL DESIGN

Prior to designing and choosing a final testing mechanism, the different areas of our testing mechanism were discussed as a group. For each area, multiple plans were suggested. After brainstorming, these plans were analyzed against the needs analysis to determine which would be best to include in the final testing device.

---

#### 3.3.1 GRIPPING

During our background research, we explored multiple methods for bone fixation during testing. These methods were analyzed and new ideas were proposed for bone gripping to utilize in the testing mechanism. The first idea produced for bone gripping was to use epoxy putty within a polyvinyl chloride (PVC) cup (Fig. 18a). Epoxy putty fixation was used in (Ahn et al., 2009) and was a sufficient gripping method for cadaveric sterna. Another gripping method proposed was to again use epoxy putty in a PVC cap, but to add a channel in the PVC cup to guide the bone tissue (Fig. 18b). These channels would guide the bone tissue so it could be aligned with the sternotomy cut parallel to the surface of the epoxy cup. Another method that also focused on tissue alignment was the hardware referencing grips (Fig. 18c). In this technique the epoxy putty fixation would be used along with the PVC cup. Across the top of the cup, two reference bars would span the width of the cup with a space in between for the bone tissue. The bone tissue would have a groove created in the anterior and posterior side of the bone, which would serve to anchor the bone in a certain orientation within the epoxy putty. Another technique described was a method using poly(methyl methacrylate) (PMMA). In this method, an aluminum box with a shaping insert, which can be disassembled, would be used as a mold to create a PMMA grips that both hold the bone tissue to be tested as well as attach to the Instron

testing device (Fig. 18d). The shaping insert would create a PMMA tab that would be gripped by the Instron machine. Lastly, a variation of this last technique was described which features a differing shaping insert that creates a cross shaped gripping tab that allows for torque testing.

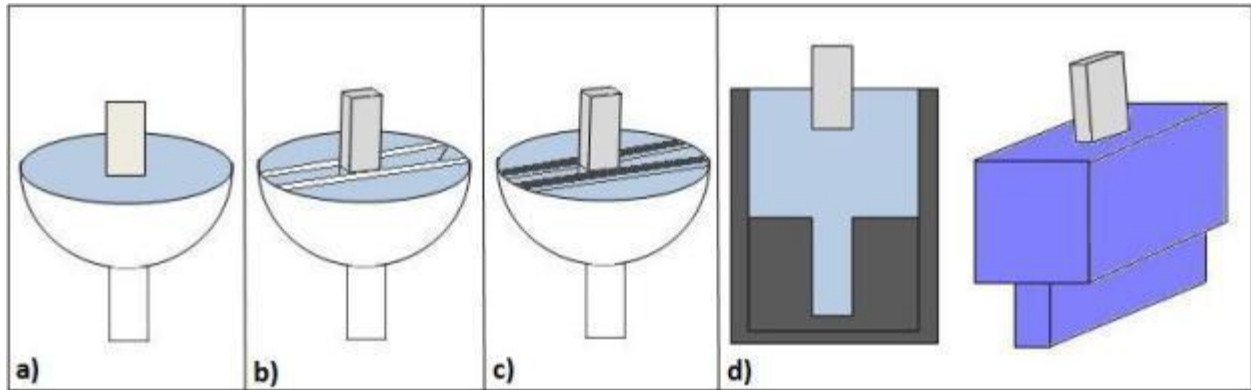

Figure 18: a) Basic epoxy putty method, b) guided channel method, c) referencing bar method, d) PMMA tab method

### 3.3.2 ANGLING GRIP

Another consideration is the curvature of the sternum, which affects how we laterally test our samples. The bone tissue must be slightly angled on either half during testing so that when each test is begun there is not an initial amount of posterior splay.

One idea for grip angling was to attach the bone gripping system to a ratcheting arm (Fig. 18a). The ratcheting mechanism would be housed where the bone gripping system meets the ratcheting arm. The grip would be able to be set at incremental settings to accommodate varying samples and would “lock-in” at the desired angle. Another proposed idea to angle grips was to use a locking cylinder pivot. This would be used in the same way as the ratcheting mechanism where the bone gripping system would attach to an arm where the locking cylinder is held. This device would not be incremental and would be able to set at any desired angle allowing for a higher degree of varying samples. The next two proposed ideas for angling are ones that were

also proposed in the gripping section above. The epoxy putty, PVC cap, and channel method could be used to angle the tissue sample as well. By slanting the referencing slats, the bone can be aligned to various angles in order to eliminate posterior splay during testing (Fig. 18b). Another method proposed in the gripping section that could also be applied to bone angling is the hardware referencing grips method. If the grooves placed in the tissue were placed slightly offset on the anterior and posterior side, it would allow the tissue to be fixed at an angle appropriate to eliminate posterior splay (Figure 18 c).

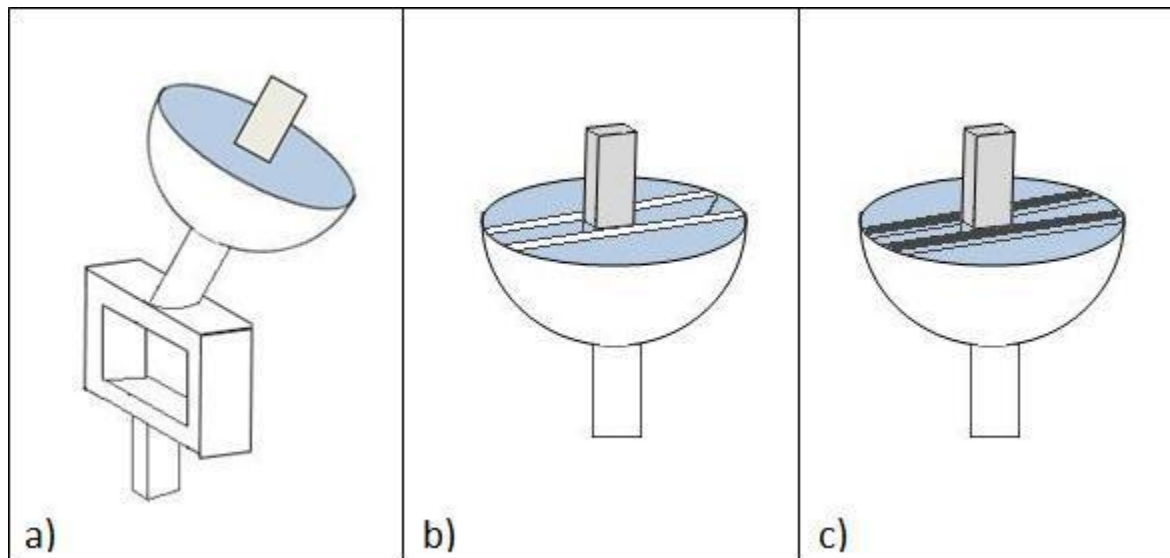

Figure 19: a) Guided epoxy putty caps with ratcheting arm attachment, b) guided channel method, c) referencing bar method

### 3.3.3 SCREW LOOSENING

Screw loosening must be analyzed during testing as a way to determine the overall stability of the fixation system. When screw loosening occurs, usually further damage to the patient tissue has taken place, which may cause the fixation system, or bone tissue to fail.

One way to acquire this information is to use real time video capture of the system with markers on the screw and on the bone to determine how the screws move overtime. A video camera would be placed to monitor the anterior side of the system being tested. Image J software would then be implemented to analyze the movement in the video gathered. Another method to measure screw loosening would be to determine the size of the screw hole before and after testing. After testing, silicon molds can be made of the screw holes. Once screws are removed from the tissue, the tissue can be bisected across the screw holes and each screw well can be filled with silicon to create molds of the holes. These molds would be compared with actual screws using water displacement tests to determine the difference in volume of the screw wells. Another means of testing screw loosening would be to conduct bone density screening on our tissue samples. The densities from before and after testing would be compared to see how much bone was lost due to screw loosening. Screw loosening can also be determined by comparing the initial minor diameter of the screw to the resulting screw hole diameter after testing. This shows us how much the screw moved during testing. Either Image J analysis or calipers could be used to make this measurement.

---

#### 3.3.4 BONE/PLATE DISPLACEMENT

In order for bone healing to occur, sternum halves cannot separate more than one millimeter per half (Pai et al., 2008). Therefore, during testing, bone separation should be monitored to analyze how different fixation systems influence the tissue. Then determinations can be made about which plate systems are most beneficial in minimizing sterna separation.

One method to analyze bone and plate movement as a result of testing would be to use a system of three real-time video captures. These cameras would be used to take anterior,

posterior, and side views of the rib pair being tested. Markers would be placed on the bone in all views for referencing purposes, and Image J software would be used to analyze the movement of the bones in relation to the plates during testing. However, since each test takes a few hours to complete, a massive amount of video information would be acquired. Another option is to take video information for the first ten seconds of testing and the last ten seconds of testing. Then, relevant information would be gathered, without having such a mass of information. Another potential method to measure bone movement is to use an extensometer (Ahn, 2009). An extensometer has two leads which could be attached to either the anterior or posterior side of the tissue to gather real time data on bone separation. Lastly, before and after pictures of the system could be taken to see the difference in separation, and any plate movement as a result of testing.

### 3.4 DESIGN ALTERNATIVES

Based on our needs analysis, we developed design alternatives for our bilateral testing device. These alternative designs are discussed in the following sections.

#### 3.4.1 DESIGN ALTERNATIVE 1: EPOXY PUTTY CUPS WITH RATCHETING MECHANISM FOR GRIP ANGLING

The first design alternative created was based on the method used in (Ahn et al., 2009) experiments. This device consists of two major components; a PVC cup and an aluminum ratcheting arm. The PVC cup, to be used with epoxy putty, is developed from (Ahn et al., 2009) and is the fixture that will hold the bone tissue being tested. The aluminum ratcheting arm will serve to angle the PVC cup and tissue sample to accommodate for initial posterior splay and also attach the testing fixture to the Instron machine. The ratcheting mechanism will allow for small incremental changes in the angle of the tissue sample and also lock into place once the desired angle is set. Where the PVC cup attaches to the ratcheting arm is where the ratcheting

mechanism is housed (Figure 19). Once manufactured, the cup will be filled with epoxy putty paste and then the bone will be potted within the medium so the anterior and posterior sides of the rib protrusion are perpendicular to the surface of the PVC cup. Angling of the grip will occur once the tissue sample and test fixture is mounted on the Instron machine.

There are several features of this design that make it a good choice for these experiments. First of all, this method has been previously used effectively in cyclic testing of cadaveric sternum (Ahn, 2009). Also, the ratcheting mechanism would enable this system to properly align the sterna for testing so clinically relevant data can be acquired. Lastly, the ratcheting arm can be reused for subsequent tests saving some of our limited budget to be used elsewhere in the project. Though this system has some compelling benefits, it also has a few drawbacks, which must be considered. For each test, a new PVC cup and several ounces of epoxy putty will need to be used. Not only is this expensive, but also contributes to environmental waste. Also, since the bone will be potted in a medium, there is not currently a way to effectively measure how the testing forces are acting on different areas of the bone tissue. It is likely that the forces throughout the bone are non-uniform, which may cause differences in data collected. Another consideration is that once the grips are angled to accommodate for posterior splay, the testing forces will be offset from the forces actually acting on the sternal fixation system. This means that further calculations will need to be conducted in order to determine the actual forces working on the tissue and this may affect experimental results.

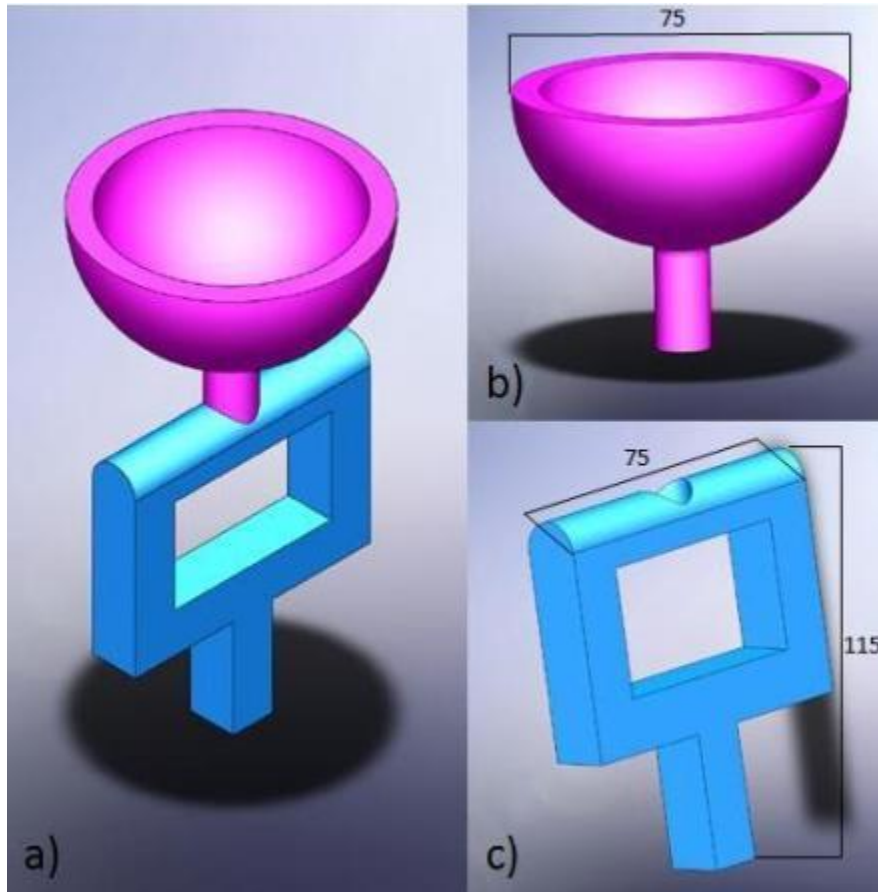

Figure 20 Epoxy Putty Cups with Ratcheting Arm for Angulation a) Assembled testing fixture, b) PVC Cups to be filled with epoxy putty, c) Aluminum arm with ratcheting mechanism to attach to Instron (measurements are in mm)

### 3.4.2 DESIGN ALTERNATIVE 2: REFERENCE BARS AND PMMA METHOD

The following design alternative consists of outer box and a reference bar system. The outer box is intended to be made of 3 aluminum parts having the capability to be disassembled (Figure 21). The reference system is made of two parallel guiding rails, which will be fixed inside the outer shell at particular distance from each other, and two mobile rectangular bars that will be sliding within the rails (Figure 21). At both ends of each rectangular bar there will be screw knob that is designed to be unscrewed in order to adjust the position of the bar within the rails. Once the position of the sternal half is determined and the knobs are tightened, then the box

is filled up with PMMA. After each test the box walls will be removed in order to remove the PMMA and bone material inside.

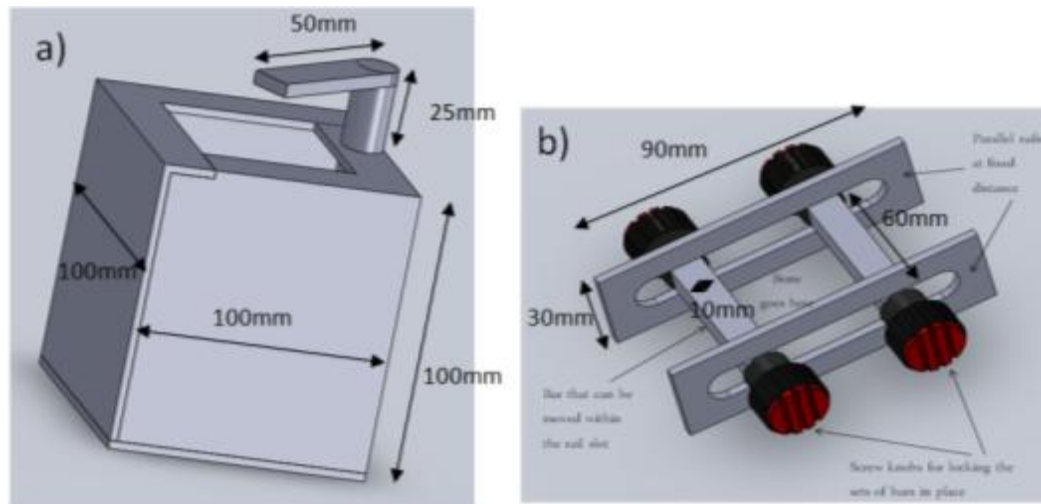

Figure 21: Reference Bars and PMMA method a) Outer box with reference lever, b) reference bar system

The reason why the guiding rails are considered to be fixed is that the mechanism is designed for testing rib pairs only. First, the size of the rib cuts can be controlled by the users of the fixture. In other words, a fixed size of bone samples can be determined so that the rails will not be necessary to be moved. Second, the cut that will be produced in order to separate a rib pair from the rest of the sternum will be straight and flat. This will provide a flat vertical interface between bone rib cut and the rail. The natural rib curvature will be addressed by the mobile bars that could be adjusted to grab the sterna bone on its anatomical anterior and posterior sides irrelevant to the sternal angle.

The reference lever on the outer box is made rotatable for the purpose of aligning the sternotomy cut to be parallel to the plane of the lever, which is parallel to the top of the box. By having consistent sternotomy cut alignment potted within the fixtures, it could be ensured more



reproducible testing that will have no or insignificant initial anterior dehiscence and posterior splay.

Some advantages of this design alternative are that it provides adjustable gripping system for the sternal sample, and also referencing lever that ensures proper alignment. This mechanism makes the test reproducible for every sample. It accommodates the sterna angulation within the box and ensures straight sternotomy at the beginning of the test. This eliminates any initial posterior splay or anterior dehiscence.

The disadvantages of this concept are related to the attachment of the referencing system to the outer box. If the mechanism is attached to the inside of the box, then the knobs will be submerged in PMMA and it is highly possible to be unable to retrieve that structure after the test is complete. Another disadvantage is the fixed distance between the guiding rails that have to be maintained since they are intended to be bolted to the box.

---

#### 3.4.3 DESIGN ALTERNATIVE 3: PMMA GUIDED ALUMINUM METHOD

The third design alternative is the PMMA guided aluminum fixture. This design consists of two fixtures (one is shown below) that can be attached to the Instron machine to perform cyclic testing. Additionally, two extensometers would be used to measure anterior dehiscence and posterior splay, and screw loosening would be measured by using calipers to measure the change in screw hole diameter.

The PMMA guided aluminum fixture is made of two aluminum parts (see below) screwed together to form an aluminum box. Inside this box are two aluminum plates that press against the rib pair in order to align the rib pair. These two plates are the “guides.” The aluminum box creates a tight fit for the aluminum guides, so that they are always aligned in

parallel inside the box. This alignment ensures that the sternum will be parallel within the box as well. The box is filled with PMMA to fixate the bone and aluminum plates inside the box. After testing, the aluminum box can be unscrewed and the PMMA can be separated from the guides and box in order to reuse the fixture. The grip at the bottom of the box can be tightened into the grips of the Instron machine at any angle necessary in order to account for the curvature of the sternum to keep it properly aligned in the fixtures.

Some advantages of this design are that the grip is reusable, the sternum is aligned to improve instrumentation reproducibility, the measurement devices are precise to improve test reproducibility, and both halves of the sternum can be gripped. Some disadvantages of this design are that the sternum is only aligned in one direction and the flat plates used to align it would not create a tight fit because of the curvature of the sternum. Without a tight fit, it would be very difficult to keep the sternum properly aligned during PMMA fixation. Lastly, the rib pair would be likely to slip from the fixture because PMMA would only surround the two sides of the rib pair not compressed by the aluminum plates.

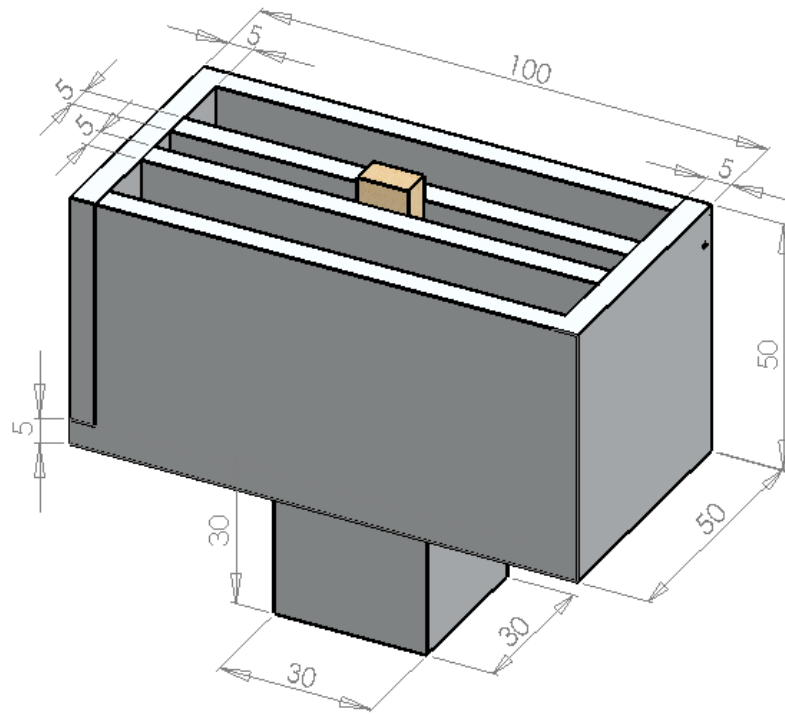

Figure 22: PMMA Guided Aluminum Grip (measurements in millimeters)

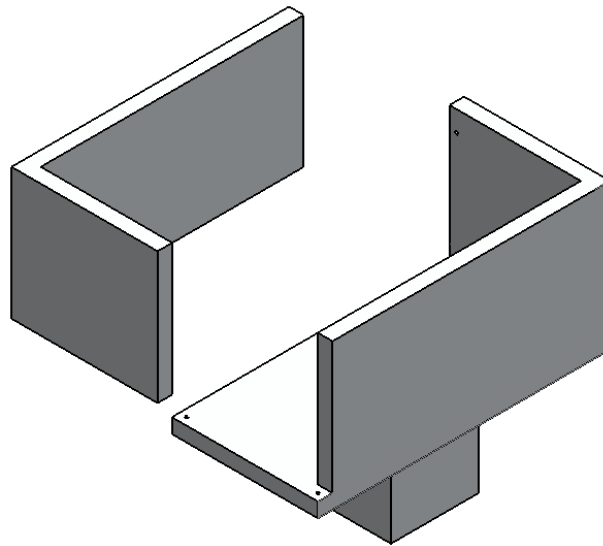

Figure 23: Two Parts of the Aluminum Box

### 3.4.4 DESIGN ALTERNATIVE 4

The compression plate method uses three sets of aluminum boxes for one fixture as seen in Figure 24. A PMMA sample where sternum halves would be potted into are placed in the middle of two aluminum compression boxes (ACB) seen in Figure 24. The ACB's are held together by adjustable metal rods for stability and alignment. The compression plate method allows for angular adjustability by loosening the ACB's and manually alter the positioning. The box fixture has a rod attached to the base that is gripped by the Instron machine. The box fixture is attached to the ACB by one rod in order to adjust the placement of the sternum from the sides. When the sternum is properly aligned, the box fixture will have to be drilled for implantation of a second rod into the ACB. Advantages of this design include simplicity, variability in angular adjustment and easily manufactured. There are various disadvantages that lead us to other designs. The design of the box fixture creates complications of unneeded torque forces during bilateral cyclic testing. Each test will always require a new box fixture due to the required drilling. The procedure will prove to be inconvenient and very expensive. The reproducibility of this method is also questionable.

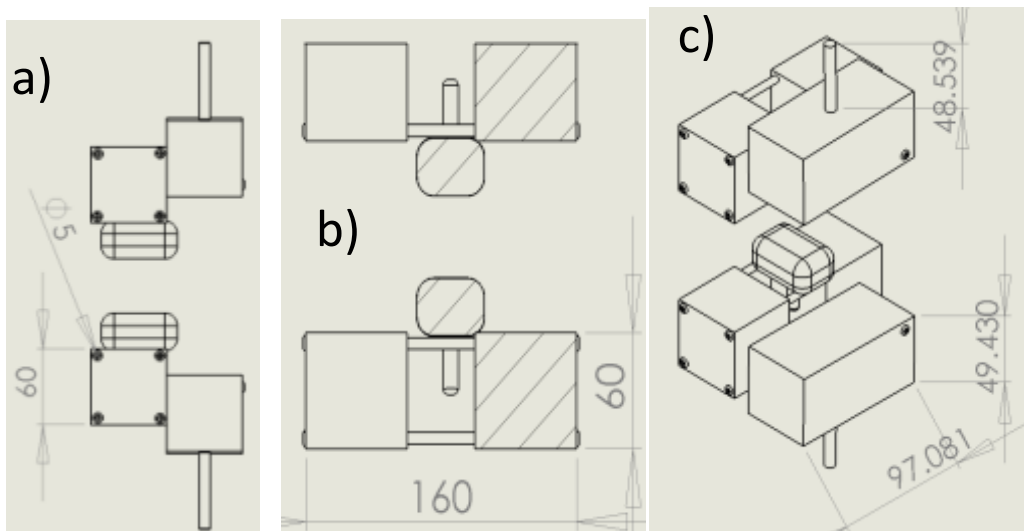

Figure 24: Design Alternative 4 – a) Side views of Aluminum Compression Box method; b) Front View; c) Overview of whole fixture

### 3.4.5 DESIGN ALTERNATIVE 5

Another design alternative was created by considering a square metal box with extension on the bottom, which has to be gripped to the Instron. The dimensions are intended to be appropriate for any sternal rib size (from manubrium to xiphoid) independent from the type of bone (polyurethane model or cadaveric tissue). The alignment of the sample within the box will be established by 2 adjustable rails that will rest on top of the fixture (Figure 25). They could be tightened with appropriate threaded rods and nuts that go through the rails. The sterna cut will be parallel to the top of the fixture and this position will be maintained by the railing system throughout the potting. Once the potting material hardens the rails can be removed prior to testing. The box is intended to be easy to disassemble for ease of putty removal. All walls have to be attached to each other with screws that are not penetrating the internal side of the box; otherwise the box will not allow to be taken apart for subsequent testing after the putty hardens.

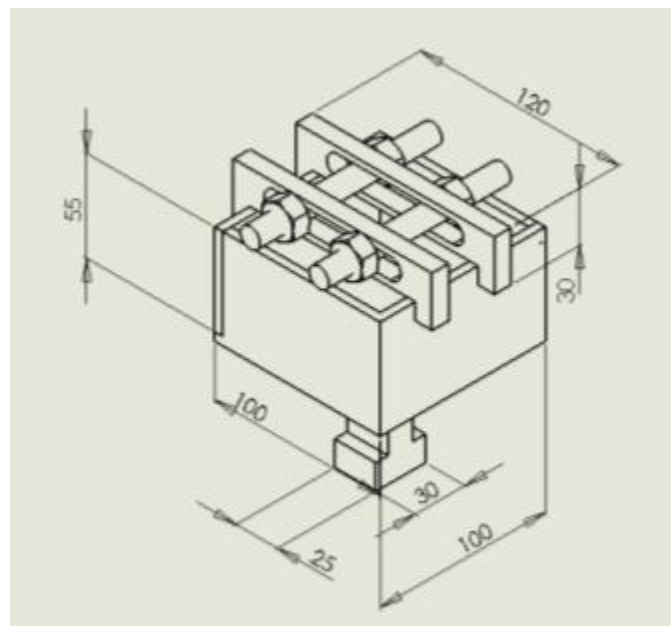

Figure 25: Design Alternative 5 - Metal box with guiding rails (all dimensions are in millimeters)

### 3.4.6 SELECTING THE FINAL DESIGN

After analyzing the proposed alternative designs, they were compared in reference to the needs analysis completed earlier in the progression of the project.

Table 5: Function-Means Analysis of Alternative Designs

| FUNCTIONS                                 | MEANS    |          |          |          |           |
|---|----------|----------|----------|----------|-----------|
|   | Design 1 | Design 2 | Design 3 | Design 4 | Design 5  |
| Perform Bilateral Tensile Cyclic Testing  | 5        | 5        | 5        | 5        | 5         |
| Sternotomy Cut Alignment (Flat or Angled) | 1        | 4        | 3        | 2        | 5         |
| Grip Alignment (Angled or Straight)       | 2        | 5        | 5        | 1        | 5         |
| Parallel Sternal Alignment with Instron   | 1        | 4        | 3        | 2        | 5         |
| Measure Anterior Dehiscence               | 5        | 5        | 5        | 5        | 5         |
| Measure Posterior Splay                   | 5        | 5        | 5        | 5        | 5         |
| M/L Displacement                          | 5        | 5        | 5        | 5        | 5         |
| Able to Grip Both Sternal Halves          | 4        | 5        | 5        | 5        | 5         |
| <b>TOTALS</b>                             | 28       | 38       | 36       | 30       | <b>40</b> |

Each alternative design was rated in each objective area in relation to one another. If all devices used the same means, all designs were given the same score in that category. If devices used differing means for a function, they were rated with points, one through five, as to which means best solved the desired function.

Alternative design five was ultimately chosen as the basis of our final testing fixture due to its high scoring elements. All devices were using extensometers to measure anterior and posterior separation, and all devices also utilized digital camera images to analyze medio-lateral displacement. Additionally, all devices use the clamping Instron grips as means of cyclic testing. Design five was found to be superior in the remaining areas. The method for aligning the sternotomy cut in this device was most advanced and enabled the tissue to be aligned both in the anterior/posterior reference frame as well as the cranial/caudal reference frame. The side bars enable the tissue to be held in the cranial/caudal frame, where the reference screws align the tissue in respect to the anterior/posterior frame. The ability to align the tissue properly is crucial

to gathering clinically relevant and useful information about how lateral forces act on sternal fixation systems. Along with this concept, it is important to consider how the grips are situated within the Instron device while testing. Design five features grips that are fixed in parallel with the Instron grips so that no angling of the grips occurs. This is important because if the grips were angled, then the plane in which testing of the tissue was taking place would be a different plane than where the Instron machine was exerting force. This causes a force offset which not only changes the load that is actually being applied to the sternal fixation system, but also alters the directions in which the forces are acting on the system. Lastly, design five uses PMMA to fix the bone tissue to the grips for testing. PMMA is used as bone cement in many orthopedic procedures and does not alter the integrity of the tissue; therefore it is a good choice when fixing bone tissue.

---

#### 3.4.7 FINAL DESIGN FOR BILATERAL TESTING DEVICE

After ranking all design alternatives it was decided that the final design of the testing fixture should consist of a box with reference guiding system and PMMA (bone cement) fill. The box is designed to have 4 separate sides and a bottom panel that are all connected with #8-32 head cap screws as shown on the CAD drawings in Appendix L - Drawings of final testing method design.

The box is also dimensioned so that it could accommodate various shapes and sizes of sternal rib pairs. As shown in Figure 26 the guiding mechanism will be positioned on top of the box. It will be composed of 2 parallel rails with slots, 2 threaded bars – size  $\frac{1}{4}$ "-20, and 4 nuts - size  $\frac{1}{4}$ "-20. The rails have protrusions on both ends so that the entire system could rest on the box and move in only one axis. This mechanism is used for positioning the sterna rib pair within

the box and its purpose is to hold the sample in place while the PMMA is poured in the box and until it hardens. After the sternal rib half is fully fixed in the box the reference guiding system can be removed by undoing the nuts. The slots of the rails are intended to have small tolerance in relation to the threaded bar in order to eliminate wobbling of the mechanism. Another feature of the fixture is the extruded T-shaped bar that provides stable grip to the Instron machine and also prevents the fixture from slipping out of the machine grip while performing lateral testing as shown in Figure 26.

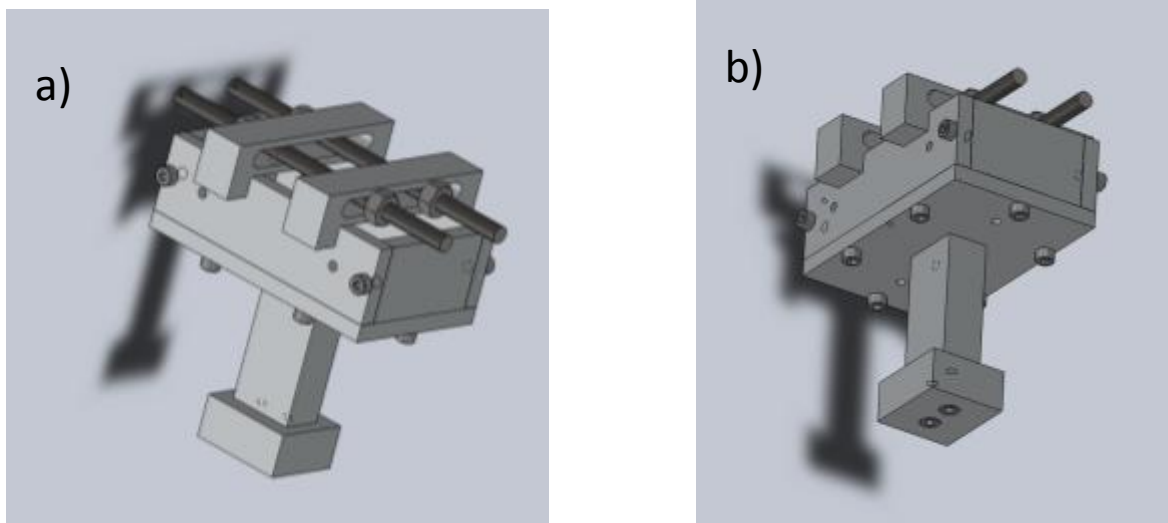

Figure 26: Final Design of Bilateral Testing Device a) view from top angle, b) view from bottom angle

From materials perspective the design of the box, guiding rails, and gripping bars are made out of aluminum alloy 6061. The threaded bar and the accompanying nuts, and the fastening head cup screws are made of stainless steel type 316. The material selection was made various reasons. First, the aluminum is light material that would be easy to mount to the Instron machine. It is preferred also for its interface with PMMA. For test reproducibility purposes the fixtures have to be cleaned up after each test and loaded with new sample the exact same way as the previous. In order to facilitate this process, the aluminum provides smooth surface that makes



PMMA removal easier. Second, using this relatively low weight metal eliminates the probability of having the fixture tilting itself within the grips. Third, given that the fixtures have to be sterilized regularly as result of their contact with biological tissues requires all fasteners and threaded mechanisms to be made out of stainless steel.

## 3.5 METHODOLOGY

### 3.5.1 HYPOTHESES

Two hypotheses were made in order to predict and test the efficiency of various fixation plates, screws, and systems that influence the screw-bone, screw-plate, and plate-bone interfaces. Each hypothesis will be subjected to testing to reveal advantageous screw and plate characteristics to reach absolute rigidity within the system. Defining these characteristics is crucial to minimize screw loosening, anterior dehiscence, and posterior splay. Minimizing these factors allows for healing and a higher success rate of union between the two halves of the sternum.

#### 3.5.1.1 HYPOTHESIS 1: SCREW-BONE INTERFACE

The screw-bone interface experiments will explore the different characteristics of the screw that can minimize screw loosening, and anterior dehiscence and posterior splay to less than 2 mm after bilateral cyclic testing. The first part of this experiment will test unicortical versus bicortical configuration. This testing will be carried out on both polyurethane bone model and cadaveric tissue. From prior research, bicortical and unicortical configuration are anticipated to perform similarly. The second part of this hypothesis is the analysis of different screw major diameters and their effects on screw loosening and bone separation. Three major screw diameters will be used; 2.0 mm, 2.3 mm, and 2.7 mm screws. This testing will be performed using

polyurethane bone model. From prior work, the 2.3 mm major diameter screws will be most effective in reducing screw loosening and bone separation. A demonstration of the screw-bone interface and anterior dehiscence, posterior splay, and screw loosening can be seen in Figure 27.

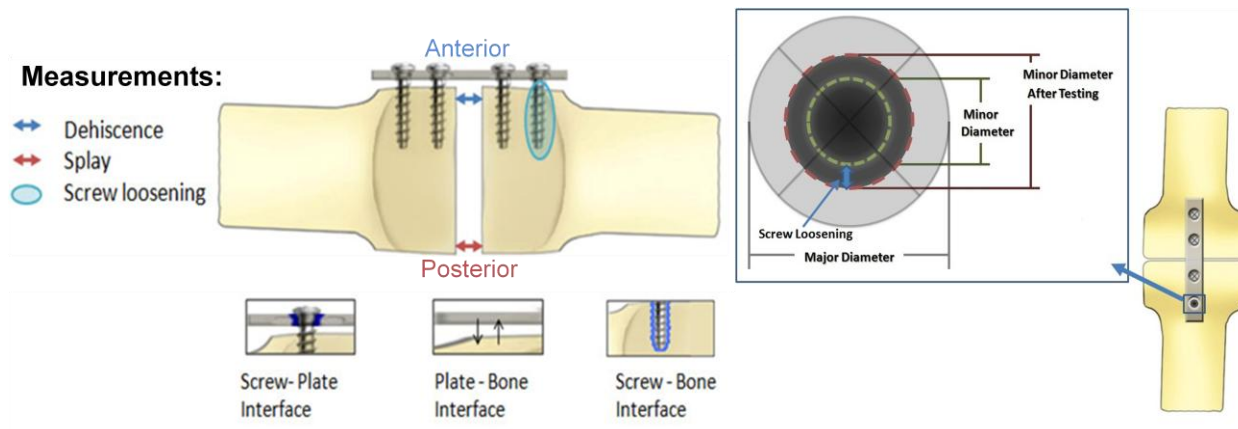

Figure 27: Depiction of the three interfaces and the three measurements taken before and after testing

### 3.5.1.2 HYPOTHESIS 2: SCREW-PLATE AND BONE-PLATE INTERFACE

The screw-plate and bone-plate interface will analyze bone separation and screw loosening to determine which type of fixation systems best reduces these measures. Compression, standard, and locking fixation systems will be studied in this experiment and will be carried out on polyurethane bone model. From prior research, the locking fixation system is anticipated to minimize screw loosening and bone separation to a higher extent than the other systems. A representation of the interfaces analyzed and measurements taken can be seen in Figure 27.

### 3.5.2 POWER ANALYSIS

In order to perform experimental testing that will generate statistically significant data the number of samples has to be determined. For this purpose a series of statistical assumptions and calculations were performed. The statistics method used is power analysis and the software is

G\*Power version 3.1.0 each hypothesis was broken down on testing groups as shown in Table 6 below.

Table 6: List of Hypotheses and the respective number of different groups tested

| Hypothesis |                        | # groups |
|------------|------------------------|----------|
| 1          | unicortical/bicortical | 2        |
| 1          | Thread diameter        | 3        |
| 2          | Plate/Screw            | 3        |
| 2          | plate/bone             | 3        |

For the first part of Hypothesis 1 (unicortical vs. bicortical) there are 2 groups only. This set up was analyzed using t-test with difference between two independent means. The effect size was determined from the average of the anterior dehiscence and the standard deviation of each group based on literature (Ahn, et. al, 2009). The allocation ratio was set to 1, which means that both groups (unicortical configuration and bicortical configuration) will have equal number of testing samples. As result the effect size was determined to be 0.7, which was further used for determining sample size based on the desired statistical significance (power). The entire calculation protocol as well as the list of assumptions can be found in Appendix H- Power Analysis.

For the rest of the hypothesis an ANOVA test was performed since they have 3 groups of different samples. The test was performed assuming fixed effects, omnibus, one-way variance. The effect size for hypothesis 2 and 3 is the same because the same samples will be used to prove them. It was found to be equal to 0.5 based on data from the literature (Ahn, et. al, 2009) and on assumption for the fixation systems that have not been reported in previous research

works. Since Hypothesis 1 has parts that consist of 3 groups an ANOVA analysis is required. The effect size was assumed to be 0.6, which denotes high effect. This means that one of the three groups that will be tested is performing significantly better and proves the hypothesis with relatively low number of samples. Reference Appendix H- Power Analysis for detailed protocols.

The power analysis was focused on 4 different statistical significance levels also known as levels of confidence or power. The most significant test is considered to have power of 95% and only 5% error but it requires high number of tests and samples. A more realistic target is 70-80%, and less confident test has power of 50%. Appendix H- Power Analysis lists all those power levels with their respective number of samples that were determined by taking into account the effect sizes for each hypothesis.

Given that the required mechanical testing is bilateral, the total number of samples should be perceived as number of rib pairs. The total number of sterna is determined by dividing the number of samples by 6. Even though there are 7 ribs attached to the sternum, only 6 of them can be physically used for plating. For the experimental design a power of 50% was used, which requires a total of 66 sternal rib pairs (11 sterna). In Table 7 is shown the breakdown of samples required for each hypothesis part.

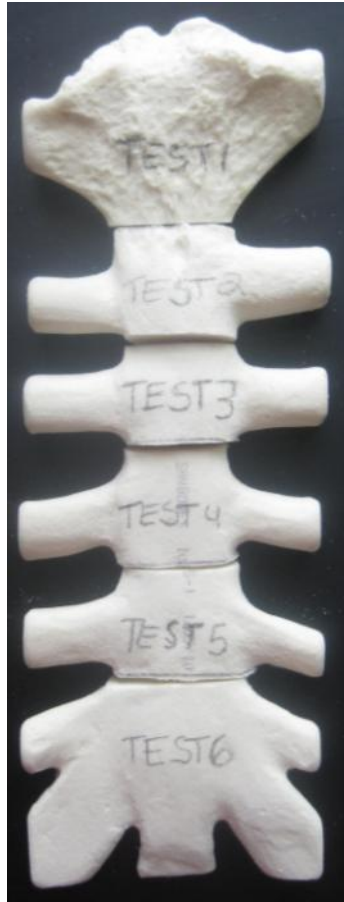

Figure 28: Sternum divided in 6 rib pairs

Table 7: Power Analysis for all Hypotheses at 50% power

| Power        |   | Hypothesis              | # groups | Test Type | effect size | # samples | # sterna  |
|--------------|---|-------------------------|----------|-----------|-------------|-----------|-----------|
| 50%          | 1 | unicortical/bicortical  | 2        | t-test    | 0.7         | 24        | 4         |
|              | 1 | Thread diameters        | 3        | ANOVA     | 0.6         | 18        | 3         |
|              | 2 | Plate/Screw; plate/bone | 3        | ANOVA     | 0.5         | 24        | 4         |
| <b>TOTAL</b> |   |                         |          |           |             | <b>66</b> | <b>11</b> |

Based on this power analysis the total number of samples and the respective hardware for each hypothesis is shown in

Table 8.

Table 8 Total number of samples required based on power analysis

|   | Description               | Hardware   | Need total # samples |
|---|---------------------------|--|----------------------|
| <b>Hypothesis 1:</b><br>cortex<br>configuration and<br>screw design | Unicortical Configuration | Standard plate<br>Screw: 7mm long; 2.3mm<br>diameter         | 12                   |
|   | Bicortical Configuration  | Standard plate<br>Screw: 11mm long; 2.3mm<br>diameter        | 12                   |
|   | Diameter: 2.0mm           | Standard plate<br>Screw: 7mm long; 2.0mm<br>diameter         | 6                    |
|   | Diameter: 2.3mm           | Standard plate<br>Screw: 7mm long; 2.3mm<br>diameter         | 6                    |
|   | Diameter: 2.7mm           | Standard plate (2.7mm)<br>Screw: 8mm long; 2.7mm<br>diameter | 6                    |
| <b>Hypothesis 2:</b><br>Plate/Bone and<br>plate/screw<br>interface  | Standard plate system     | Standard plate<br>Screw: 7mm long; 2.3mm<br>diameter         | 8                    |
|   | Compression plate system  | Compression plate<br>Screw: 7mm long; 2.3mm<br>diameter      | 8                    |
|   | Locking plate system      | Locking plate<br>Screw: 7mm long; 2.3 mm<br>diameter         | 8                    |

### 3.5.3 STERNUM AND FIXTURE PREPARATIONS

Many steps will be taken to ensure that samples are tested in the same way every time. This section details the steps we will take to prepare samples and fixtures, how measurements will be take before and after testing, and also give an overall description of our testing method.

To prepare our polyurethane sternum samples and fixtures, several steps are taken (for full protocol see Appendix Q - Full Protocol). First, a line is drawn on the sample marking where we want the potting material to come up to. This is done by measuring two centimeters

from the sternotomy cut and drawing a line around the rib section of the sample. In order to guarantee proper adhesion of the sample and potting material, the region on the sample to be submerged was scoured with a scalpel. After this procedure, the sample was thoroughly vacuumed to remove any excess particles that might affect putty adhesion. Testing fixtures were prepared for each test as well. First, all excess putty was scraped from the fixtures so proper adhesion and alignment of samples can occur. Next, the inner walls of each fixture were lined with one layer of scotch tape so putty can be released from the fixtures post-test. The sample was then aligned in our referencing system. It is first placed so that the two centimeter marker line is aligned with the top edge of the box fixture. The sternotomy cut was aligned so it is parallel to the top of the referencing system. The cut edges of the sample are held by the flat guiding rails of the system. Then, the threaded rods hold the anterior and posterior sides of the sample in place and are tightened. To pot samples, the all-purpose putty components must be mixed together. One and a half scoops of putty were measured along with one and a half lines of hardener and mixed in order to fill one fixture. The components are mixed for about a minute and then poured into a taped fixture. Once the putty has been added, the aligned sample in the guiding system is placed on top of the fixture. Proper adhesion is ensured by pushing the putty towards the sample once potted. This is allowed to dry for approximately a half an hour. To pot the remaining half of the sample, the first fixture is inverted and gripped by the top clamps of the Instron Machine. The second fixture is filled with putty the as described above. This fixture is then placed in the lower Instron grips aligned underneath the sample. Using the “jog down” function of the Instron machine, the sample is submerged into the putty up to the potting line. Putty is pushed towards the sample to ensure adhesion. The sample is left to dry for about a half an hour.

Once the putty has fully solidified, the sample is ready to be tested. C-clamps are added on either side of the fixtures and putty to hold putty inside the fixtures during testing. Pictures of the anterior and posterior side of the sample are taken prior to testing. Then the test can begin.

To prepare the cadaveric sternum samples some different steps were taken before potting. First, the tissue was removed from the refrigerator and allowed to sit for approximately thirty minutes to warm up to room temperature. At this point, a scalpel was used to remove the periosteum layer from the rib sections of the sample. Once cleaned, a layer of super glue was applied to the rib sections. This sealed off any moisture from the sternum itself. From this point the same method was used to align the cadaveric samples and pot them as the polyurethane samples.

---

#### 3.5.4 PROGRAMMING

---

##### BLUEHILL PROGRAM

In order to perform lateral cyclic testing, Instron 5544 machine was used. It is controlled by Instron Bluehill software. A specific program was created in the software to command the motion of the machine at a given speed, force, and number of cycles. Since the clinically relevant loading of the chest is up to 50 N (Pai, 2008), the Bluehill program was designed to make an upward motion until it reaches  $50 \text{ N} \pm 0.4\%$ , and then to return to  $0\text{N} \pm 0.4\%$  at the same rate. One full cycle is considered to be one pull up (to  $50 \text{ N} \pm 0.4\%$ ) and one release of the loading down (to  $0 \text{ N} \pm 0.4\%$ ). Initially the program was intended to perform 15000 cycles at rate 200 N/s, which results as 2 cycles per second (2 Hz) as referenced from the literature (Pai, 2008) but during validation testing it was discovered that the limitations of the load cell do not allow frequency higher than 0.5 Hz. Taking into account this technical restriction the program was



created to move the load cell at a rate 30 N/s. This is equal to frequency of 0.33 Hz (0.33 cycles/sec). In order to keep the total time of the test within reasonable time frame it was necessary to lower the number of cycles to 2500.

Another aspect of the Bluehill program was improved after the initial setup was tested. After the test was over it was set to “return” option, which is intended to return the load cell to the initial gage length set at the beginning of the test. This was found to impede the capability of taking picture after test completion in order to measure anterior dehiscence and posterior splay. For this purpose the end of the test was set to “Stop and Return”. The return of the load cell to gage length is executed after confirming in the pop-up window in Bluehill.

---

#### 3.5.5 PRE AND POST TEST MEASUREMENTS

Prior to testing several measurements of each sample were taken. The angle of the sternotomy cut to the plate and the plate orientation in relation to the ribs were measured to determine how straight the plate was applied. A ratio comparing rib width and length of rib pair will be documented. Initial separation of sternotomy halves will be recorded on the anterior and posterior sides of the sample at both the superior and inferior edges. Bone plate separation at each screw site and whether the plate was contoured to each sample will be recorded. The “looseness/strength” of the system will be recorded prior to testing. A 1-5 scale as described in Appendix Q - Full Protocol was used objectively by teammates to determine overall sturdiness of each sample. Several pictures of each sample were taken. Lastly, any other notable information about each sample was recorded for future reference and comparison.

Following the completion of each test, several other measures were taken for each sample. Screw loosening was measured by measuring the resultant screw hole size using

calipers and comparing this value to the major diameter of the screws used. Resulting separation of the sternal halves was measured by taking digital pictures of each sample. These images were uploaded and analyzed using Image J software. The reference points on the samples made prior to testing were measured with the software to gain a final separation measurement which was compared to the initial separation measurement. The strength of the system was decided upon by the observations of the team members using the 1-5 rating system.

---

#### 3.5.6 IMAGE PROCESSING

ImageJ was used to measure dehiscence and splay before and after testing. ImageJ is a Java based program used for image processing and analysis developed by the National Institute of Health. ImageJ is mainly used for cell counting and cell measurements but can be used for a variety of applications. A Canon Power Shot SD1100IS camera was used to document the sample prior to and after testing. The camera used produced an image of 3264 by 2448 pixels per picture. Each image was documented while fixated to the Instron machine with a calibration ruler placed at the plane of the samples being tested. Images were taken at a set distance of 25 cm away from the Instron machine on the anterior and posterior side of the sample for consistency and accuracy. The placement of the calibration ruler is crucial to set the scale of the amount of pixels to a known distance. By setting the scale of the image, the program is capable of measuring the gap between the cut samples by translating pixels to distance. The image was taken while fixated to the Instron machine. This was due to the fragile state of the sample after testing and for consistency. Black dots were placed superior and inferior ends of both posterior and anterior sides of the bone models to compare differences after testing shown in Figure 29.



Figure 29: Images taken prior to testing on the anterior and posterior side

At first, during the image analysis, we decided to measure each sample from the edges of the dots but this proved to be inaccurate due to the picture quality. After a few attempts it was apparent that the edges of the dots blurred due to small movement, image perception, and shadows portrayed. Using the drawing tool within ImageJ, an ellipse can be made to encircle the dot and measurements can be taken to obtain the average X and Y values to pinpoint the centroid. Each measurement taken was documented using ROI (Region of Interest) manager shown in Figure 30. It was then concluded that measuring from the centroids of the dots proved to be accurate and precise.

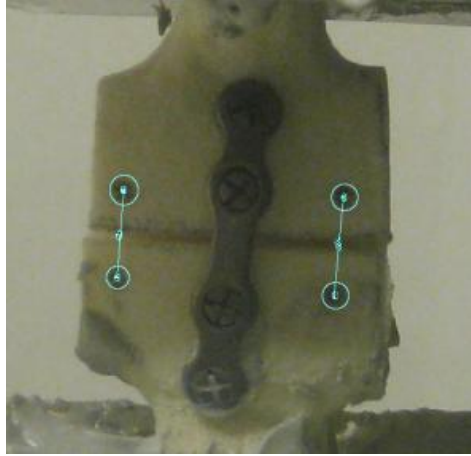

Figure 30: Documented measurements using ROI manager showing the distance between the centroid of each dot

The precision of the ImageJ software is 0.5 pixels. Each image has its own precision value depending on the calibration set to each image, image resolution, and the straightness of the measurement.

---

### 3.5.7 VALIDATION OF TESTING METHOD

---

#### PMMA TESTING

The preliminary validation of the testing method utilized PMMA bone cement to pot sternum samples within the previously discussed aluminum fixtures. The bone cement, Depuy PMMA surgical bone cement, consists of two monomers kept separate until potting was about to commence. Though the bone cement adhered well to the sternum samples, it did not adhere well to the fixture walls. This caused some slippage of the hardened medium during cyclic testing. This caused additional strains on the sample when an edge or corner of the medium slipped, or sometimes caused tests to fail entirely as the entire block of PMMA would pull out of the fixture during testing. In addition to these slippage problems, the type of bone cement needed was too expensive for our budget. In altering our test method, we looked to different mediums to use for testing.

---

## ALL-PURPOSE PUTTY

All-purpose putty, by Bondo, was obtained for further testing method and fixture validation. Like the PMMA, this putty also consists of a two part method where a hardener is introduced so that the putty will become firm. Putty proved to be much better in terms of affixing to the walls of the aluminum fixtures. No failures were observed during validation because of slippage of the medium. However, the medium became so adhered to the fixtures the only way to remove the putty was to utilize a hammer and chisel and a high powered brush for full putty removal from the fixtures. This decreased our timeline too much so further improvements needed to be made to our system. By applying a layer of scotch tape to the inside of the aluminum fixtures, the putty was then easily removable simply by disassembling our fixtures as planned. Occasionally during testing medium slippage or pull-out from our fixtures was observed. To remedy this, small 2.5 inch c-clamps were obtained from a local hardware store. These clamps were applied on either side of each filled fixture to hold the block of putty in place with the fixture. Far less slippage was observed in validation using putty than with PMMA, so the clamps are mostly a precaution. In addition, Bondo all-purpose putty was a far more economical substance to use for our project allowing us to do the full number of tests planned while staying within budget.

---

## OPTIMIZATION OF FIXTURE DESIGN

Based on the initial drawings the fixtures had been manufactured and evaluated by the team. The first consideration was related to the volume of the potting material that had to be inserted in the fixture for every single test. In order to reduce the costs of the testing method the design was optimized. The short sides of the box walls were moved towards the center of the fixture, which reduced the volume almost twice. The only manufacturing alteration made was

drilling 3 more holes for each wall (2 on the sides, one on the base). These changes are found to have no interference with the potting section of the sterna sample. Enough potting material was able to surround the rib portion, which kept the validation samples intact with the putty during testing. Reference Appendix L - Drawings of final testing method design for complete fixture drawings and material specifications.

---

### 3.5.8 DATA ANALYSIS

---

#### BONE SEPARATION

The raw data generated from the load cell of the Instron machine was used to determine the distance between the sternal halves. This raw data included information about the number of cycles, time, loading, and displacement of the load cell. In order to determine the total distance between the sternal halves it was necessary to plot the graph of displacement vs. cycle count. The displacement was taking into account the measurement of splay and the dehiscence but it gave information for displacement in general. Each sample was analyzed by taking the maximum values at every 10 cycles until 100, and then at every 100 cycles up to 2500. The first 10 cycles were considered to be pre-cycling, so the total displacement was found by subtracting the maximum at cycle 10 from the maximum at cycle 2500. For samples A2, A4, B4, and B5 the last cycle was considered to be cycle 2499, because there was a spike in the load on the very last cycle due to an issue with the custom Bluehill program. Full list of the plots can be found in Appendix S – Full list of load cell data analysis.

## SCREW LOOSENING

Screw loosening was analyzed by measuring the final hole diameter at each screw location and subtracting the initial minor screw diameter from it (Figure 31). For better understanding the screw loosening concept all values were converted to percent change in order to account for the different screw sizes. The initial minor diameter for the 2.0 mm major diameter screws is 1.5 mm, whereas for the 2.3 mm screws the minor diameter is 1.9 mm. Each sample was represented with a single screw loosening value, which was the average of all 4 screw hole percent changes for the particular sample. Only the samples that completed testing were analyzed. A full list of all measurements can be found in Appendix T – Full list of screw hole measurements.

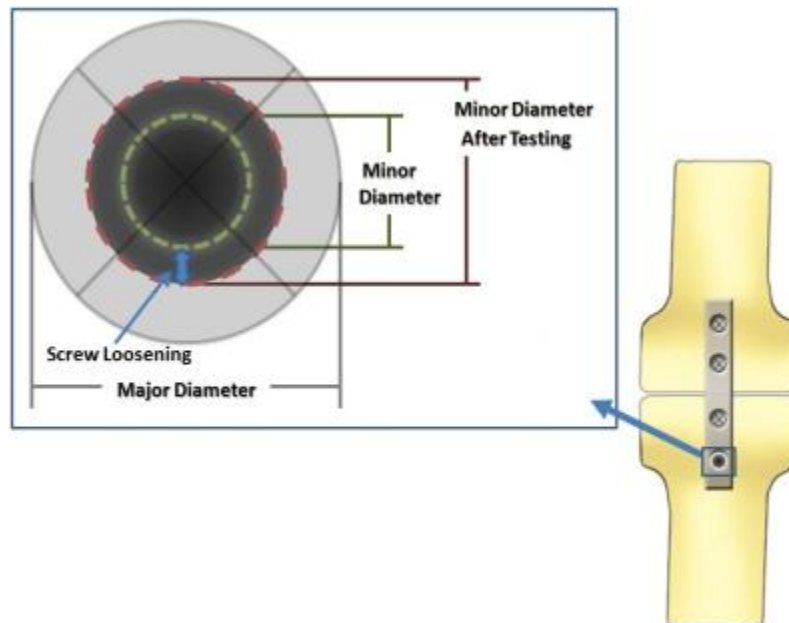

Figure 31: Screw loosening measurement

---

## FAILURE MODES

Two failure types were defined to categorize the different fails observed during testing. The first one is called setup failure and it includes all samples that were not able to complete the test (2500 cycles). The major reasons for this failure type were: screws pulled through a rib pair half, the screws were stripping from the bone and the sample fell apart, and the bone breaking at an end screw hole that was drilled all the way through the sample. The second failure type is called fixation failure and it is defined as the samples that finished testing but they were not able to minimize the distance between the sternal halves to less than 2 mm. For data analysis purposes the setup failures were excluded from the data sets, but the fixation failures were included. A complete list of all test samples showing if the samples pass or fail can be found in Appendix U – Full list of tested samples (pass/fail).

---

## STATISTICAL ANALYSIS

In order to analyze if the difference between the groups of samples was statistically significant, we performed ANOVA Single factor analysis with significance level  $p < 0.05$ . For this purpose Microsoft Excel 2007 was used.

---

## COMPUTER SIMULATION – WORKING MODEL 2D

Software Working Model 2D was used for the development of a computer simulation representing bilateral forces on a rib pair. The outlines for the rib pair sample were taken from a top view photo of the polyurethane test sample B3 used for in vitro testing (Figure 32). Only the section that was out of the putty was included in the model system. The forces were applied to the both sternal halves at the end of the rib section. The hardware on the actual sample was a standard plate with 4 screws – 2.3 mm major diameter and 11 mm long. The dimensions of the



modeled plate were proportional to the real plate that was on the polyurethane sample. It was made of 4 points and 3 rods connecting them. The purpose of the plate having 3 sections was to be able to measure the tension in the rods between the screws and to evaluate their magnitude.

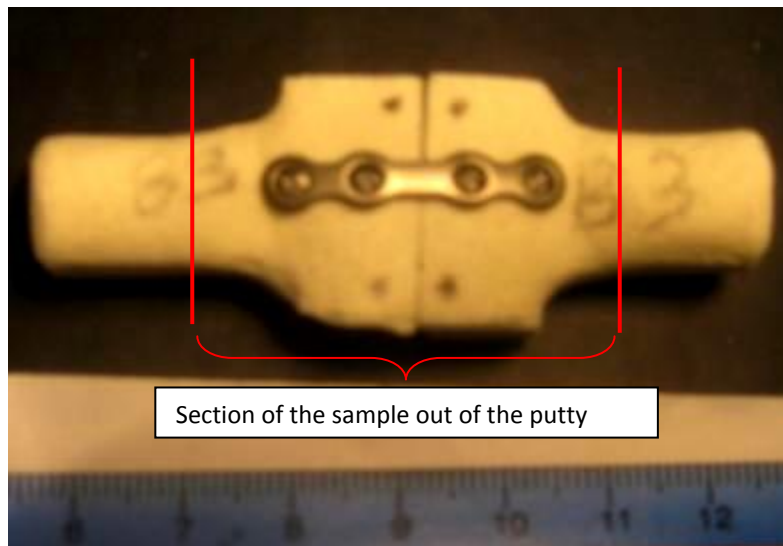

Figure 32: Polyurethane rib pair used for computer simulation modeling (Sample B3)

The goal of the modeling system was to validate a sternal rib pair model with the data that was obtained during testing with the Instron machine. Once validated, the software can be used to model different configurations and sternal fixation systems in order to evaluate various parameters such as bone separation and tension in the plate, as well as torque or modes that are difficult to test in a live test.

Based on the setup failures that resulted in the polyurethane testing there were 2 major reasons for failure. The plate was too offset and was not in line with the applied force, or the plate was placed at an angle that caused the screws to pull through due to the torque created from the force distribution on the screws.

There were 4 dots placed on the sample for markers. They were used for tracking the bone dehiscence on the superior and inferior sides of the anterior view. Other measurements

were taken were made at each rod that connects the screw models. The tension in those rods was important in order to analyze the sections of the plate that bear the majority of the loading. This analysis will help in predicting which screws are likely to fail given the position of the plate relative to the loading direction.

## CHAPTER 4. RESULTS/DISCUSSION

### 4.1 PRE-TESTING RESULTS FOR FIRST HARDWARE APPLICATION

Once all of the pre-testing measurements for the first set of testing were recorded, they were analyzed to note any trends in plate centering, plate contouring, plate placement regarding the angle of plate from the sternal cut, and overall looseness of the bone/plate/screw system. Figure 33, Figure 34, and Figure 35 depict how these measurements were taken. A series of three analyses were conducted to analyze these four measurements. The first analysis compared the four measurements across each whole sternum independent of the plates and screws that were applied. The second analysis compared the four measurements across each rib pair independent of the plates and screws that were applied. The final analysis compared the four measurements based on the screws and plates that were applied according to the three hypotheses described in 3.5.1 Hypotheses. The data from this section will be useful once all of the testing has occurred because conclusions can be drawn regarding tolerances for the final design based on the relationships between pre-testing measurements and results and post-testing measurements and results.



Figure 33: Schematic of how plate centering was measured during pre-testing



Figure 34: Plate contouring

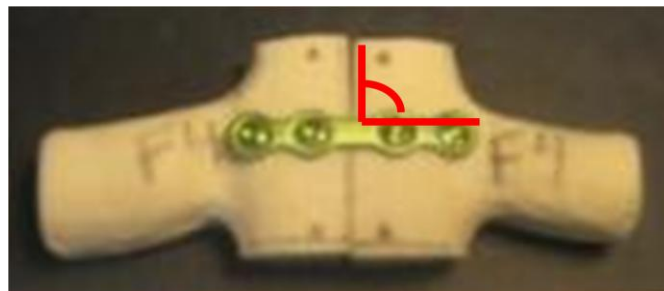

Figure 35: Schematic of how plate angle was measured during pre-testing measurements.

---

#### 4.1.1 COMPARATIVE ANALYSES OF INDIVIDUAL STERNUM

The first set of analyses conducted using the pre-testing measurements were between each individual sternum independent of the types of plates and screws applied. These results can be useful to evaluate the trends of how the plates and screws are applied. It is interesting to note the variability of how each resident applied the plates and screws and how the measurements vary from sternum to sternum. Note that the total number of plates for each sternum varies

between 5 and 6 because not every rib pair of every sternum was utilized for testing in the first round of testing.

The plate centering for each sternum was analyzed first. As described in the methodology, plate centering was measured as the distance from the left and right edges of the plate to the start of the left and right rib struts. This analysis is useful because it can give a better understanding of how fixation systems are applied and variations in application based on the person who performs it. Figure 36 summarizes the plate centering for sternum A, B, C, D, E, and F.

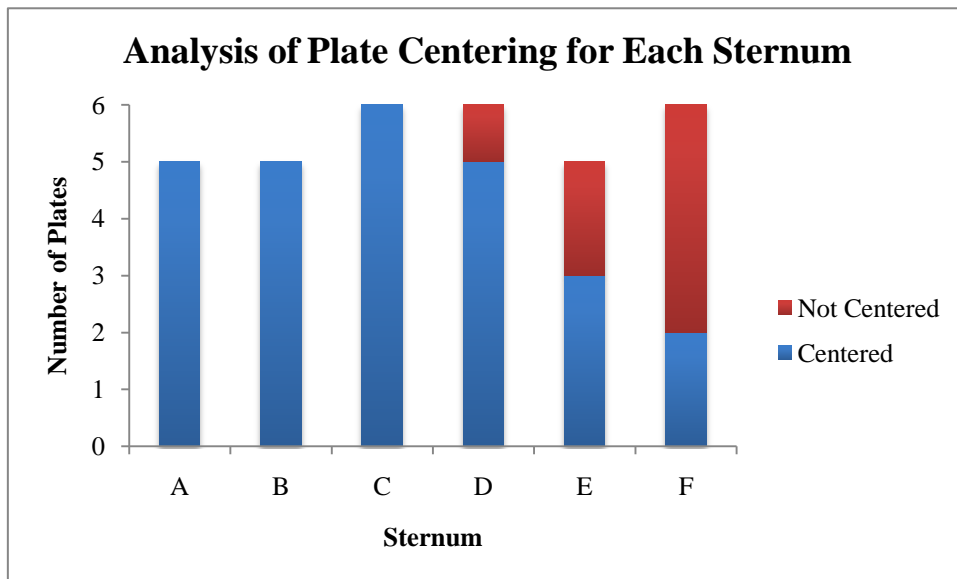

Figure 36: Plate centering for each sternum independent of the types of plates and screws applied

All of the plates on sterna A, B, and C were centered, the plates on sternum D were mostly centered, and the plates on sterna E and F had several plates that were not centered. This could be a result of a more experienced resident applying the hardware to A, B, C, and D, or it could be a factor of the types of plates and screws applied to these sterna. It is also possible that

the plates and screws applied to A, B, C, and D were easier to apply than those on the other sterna and therefore centering was easier to establish.

The second pre-testing measurement that was analyzed was plate contouring. The project team instructed the residents to apply the plates as they would do in surgery, which meant that they could choose when and when not to contour the plates. Plates that were flushed to the bone without having to be manually contoured were also considered to be contoured. This analysis is important to understand trends in how the residents applied fixation systems because contouring is a choice made by the applicator. The summary of plate contouring can be seen in Figure 37.

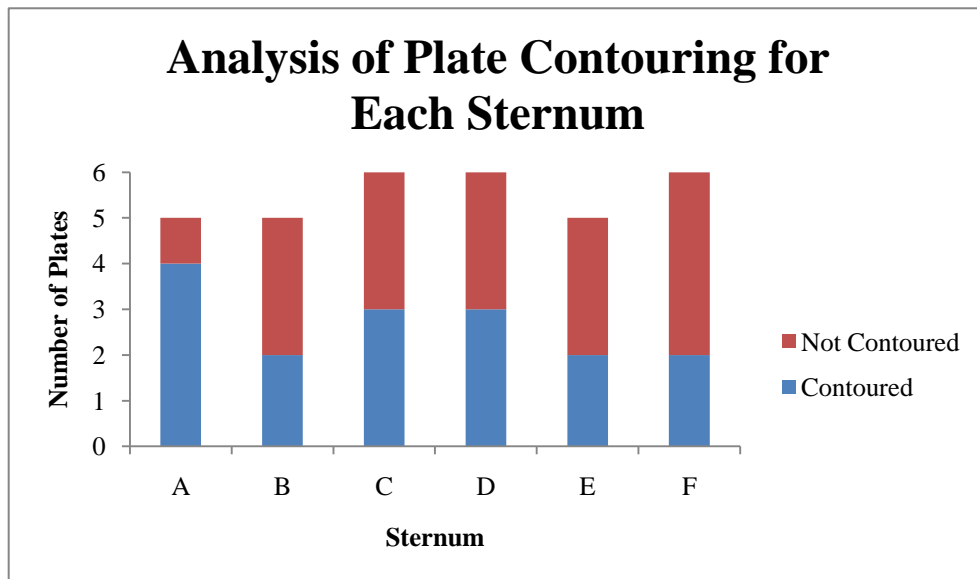

Figure 37: Plate contouring for each sternum independent of the types of plates and screws applied

It is clear from this graph that the variability in contouring for each individual sternum is great. This is partially due to resident surgical preferences, but it is likely that the residents chose to contour plates as a result of the types of screws and plates they were applying as well as the shape of the rib pairs to which they were applying the plates. About half of each sternum, with the exception of sternum A, was contoured while the other half was not. It is possible that

this is a result of the shapes of each rib pair because some pairs are flatter while others are rounder and more obscure. These concepts will be discussed further in the following sections regarding analyses of rib pairs and plate and screw types.

The third comparative analysis that was made for each individual sternum was plate placement. Plate placement was measured as the angle from the sternal cut to the top edge of the plate. The placement of the plates would ideally be 90.0°, but various factors caused this angle to be off by a few degrees. Most likely, the cause for angle variability was due to the shape of the rib pairs and the types of plates and screws that were applied because these factors can make application more or less difficult. Figure 38 shows a summary of the plate placement for each sternum.

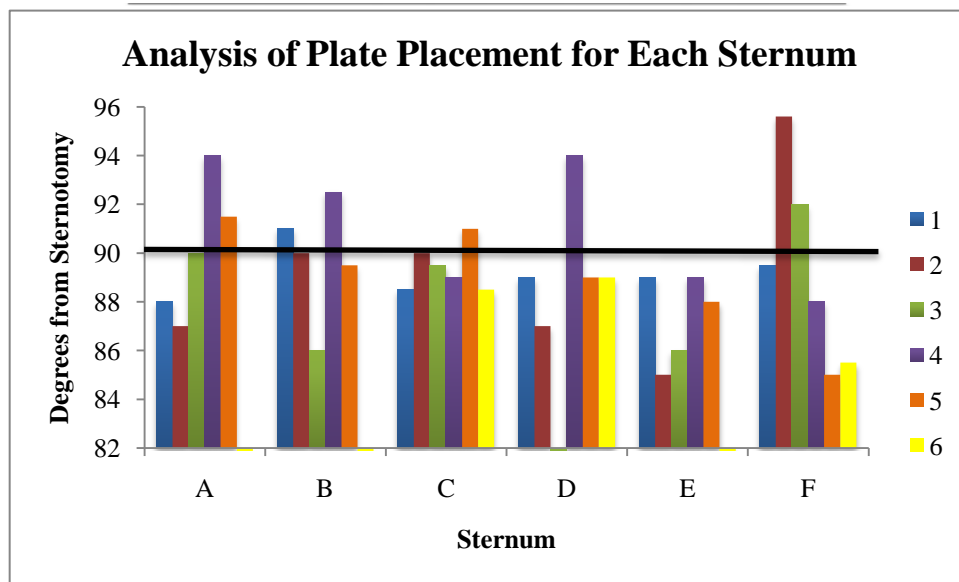

Figure 38: Plate placement for each sternum independent of types of plates and screws applied. 90° is the ideal angle of the plate from the sternal cut.

The black line in the graph identifies the ideal 90.0° angle for plate placement. Most of the plates were placed within 0.0-3.0° of this ideal angle, and all plates were within 5.0°. Sternum C had the most consistency of placement with all plates placed within 1.5° of 90.0°.

This consistency is likely due to a more experienced resident or the type of plates and screws that were applied to it might have been easier to apply.

The final measurement that was analyzed with respect to individual sternum was the looseness of the bone/plate/screw system. As described in the methodology, the looseness was measured using a 1 to 5 scale where a 1 was given to a system that fell apart and a 5 was given to a very rigid system. A system was considered rigid if it did not move in any direction when force was applied. The summary of this data can be seen in Figure 39.

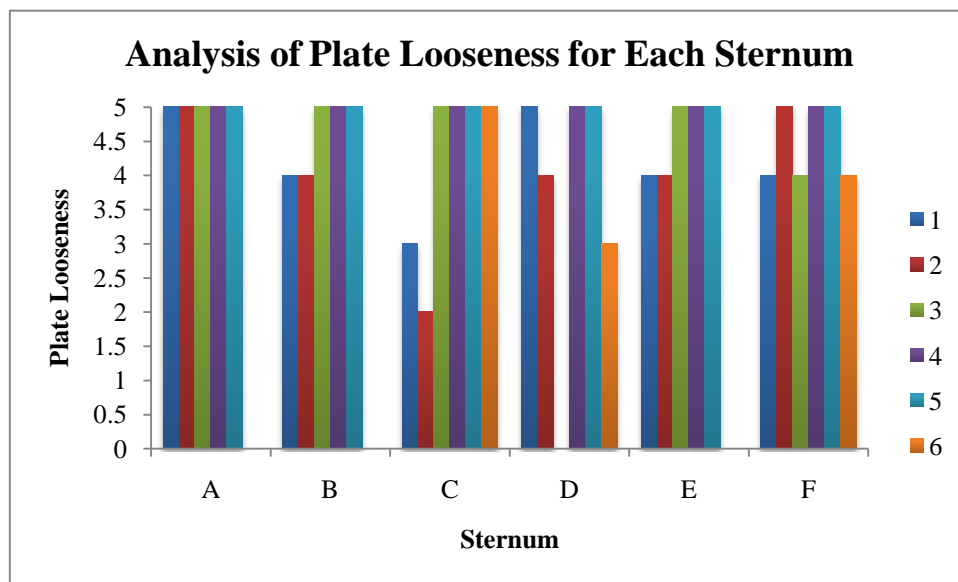

Figure 39: Looseness of the bone/plate/screw system for each sternum independent of the types of plates and screws applied. A rank of 5 is very rigid and a 1 means the system fell apart.

Sterna A, B, E, and F all had fairly to very rigid systems as they received fours and fives for their looseness rankings. This rigidity does not seem to be closely correlated to plate contouring or placement since contouring and placement for these sternum varied greatly; however, there may be a relationship with the plate centering. All of the plates on sternum A and B were centered, which may be a reason for the rigidity of the system. This relationship does not appear to be true for sternum E and F however because several of their plates were not centered,

yet they still seemed to have very rigid systems. As will be discussed in the following sections, the rigidity of these systems is likely a result of the types of plates and screws that were applied. The variability of the rigidity of the systems from sterna C and D is also likely due to the plates and screws that were applied to them.

#### 4.1.2 COMPARATIVE ANALYSES OF INDIVIDUAL RIB PAIRS

The second set of analyses conducted using the pre-testing measurements were between each individual rib pair independent of the types of plates and screws applied. Figure 40 shows each rib pair of the sternum and how they have been numbered for the purposes of this paper. Similar to the first set of analyses, these results can be useful to evaluate the trends of how the plates and screws are applied. It is interesting to note the variability of how each resident applied the plates and screws and how the measurements vary from rib pair to rib pair. As was the case for the previous section, the total number of plates for each rib pair varies because not every rib pair was utilized for testing in the first round of testing.

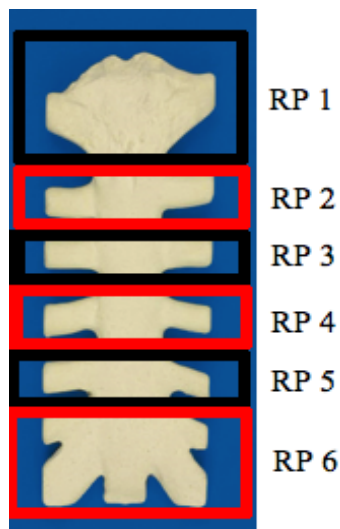

Figure 40: Pictorial representation defining the 6 rib pairs of a sternum. Rib pair 1 is the manubrium, rib pairs 2-5 are the body, and rib pair 6 is the xiphoid region.



The first analysis that was conducted for the pre-testing measurements of each rib pair was plate centering. This analysis was important because it showed if there was a relationship between the size and shape of a rib pair and the ability to center the plate on it. A summary of plate centering results can be seen in Figure 41.

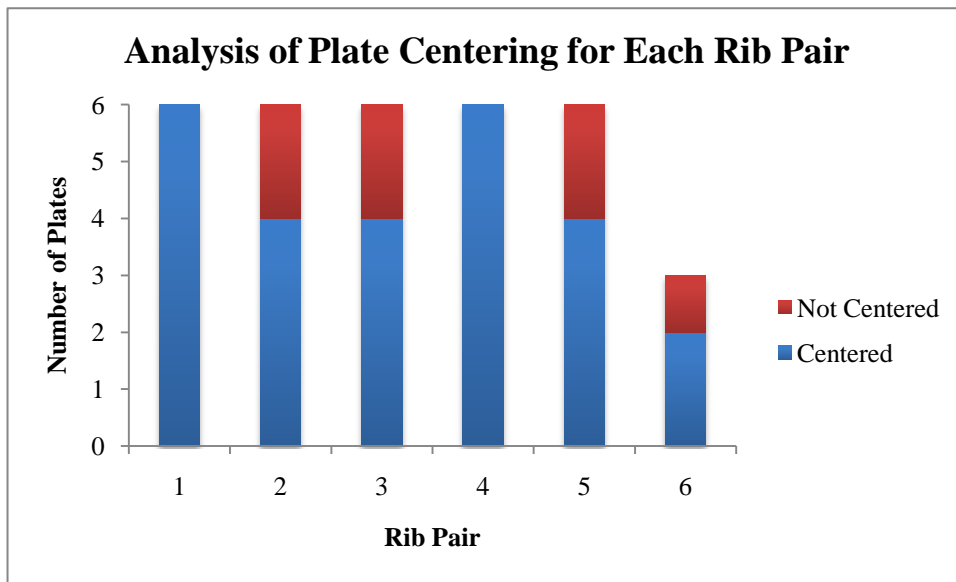

Figure 41: Plate centering for each rib pair independent of the types of plates and screws applied

All of the plates applied to rib pairs 1 and 4 were centered, while one-third of the plates for rib pairs 2, 3, 5, and 6 were not centered. The reason that the plates are centered or not centered could be due to the shape of the rib pairs as well as the expertise of the resident that applied the plates. Rib pairs 3 and 4 are fairly flat in the lateral direction (left to right) as well as straight, which would seem to make a centered application of the plates easier to do. However, rib pair 3 has two plates that are not centered, which makes plate non-centering seem more likely to be a result of human error during application and less a result of the rib pair shape. This statement is further validated by the fact that the manubrium, rib pair 1, is the most obscurely shaped, yet all of the plates on these pairs were centered.

The second analysis conducted on the measurements from the rib pairs was regarding plate contouring. Note again that plates that were not manually contoured, yet were still flush to the bone, were considered contoured for this analysis. This analysis was important to determine if there was a relationship between the size and shape of a rib pair and the choice to contour or not contour. A summary of data for plate contouring can be seen in Figure 42.

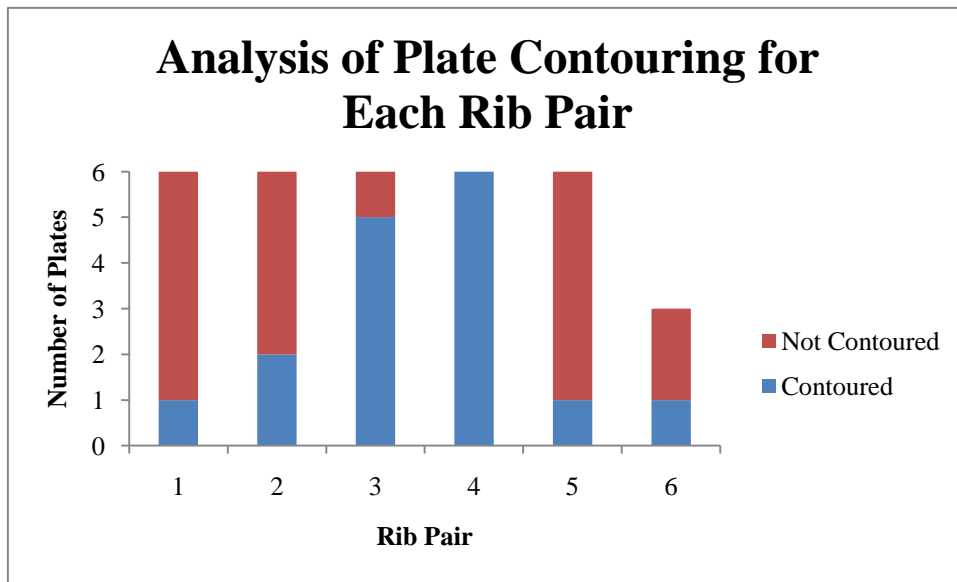

Figure 42: Plate contouring for each rib pair independent of the types of plates and screws applied

As previously suggested during the analysis of plate contouring for each individual sternum, plate contouring seems to be very closely related to the shape of the rib pair that it is applied to. Both rib pairs 3 and 4 had most or all of the plates applied to them contoured. These rib pairs are both laterally flat and therefore the plates did not need to be bent in order to contour to the shape of the bone. All other rib pairs had very few plates contoured to them. This is likely because the residents used their personal discretion for contouring. Contouring to the other rib pairs, particularly the first rib pair would be difficult to do as a result of their obscure and uneven shaping. The type of plates and screws applied could also affect this difficulty.

Plate placement was the third pre-testing measurement that was analyzed by rib pair. The ideal angle for plate placement was 90° from the sternal cut. Figure 43 shows a summary of this analysis.

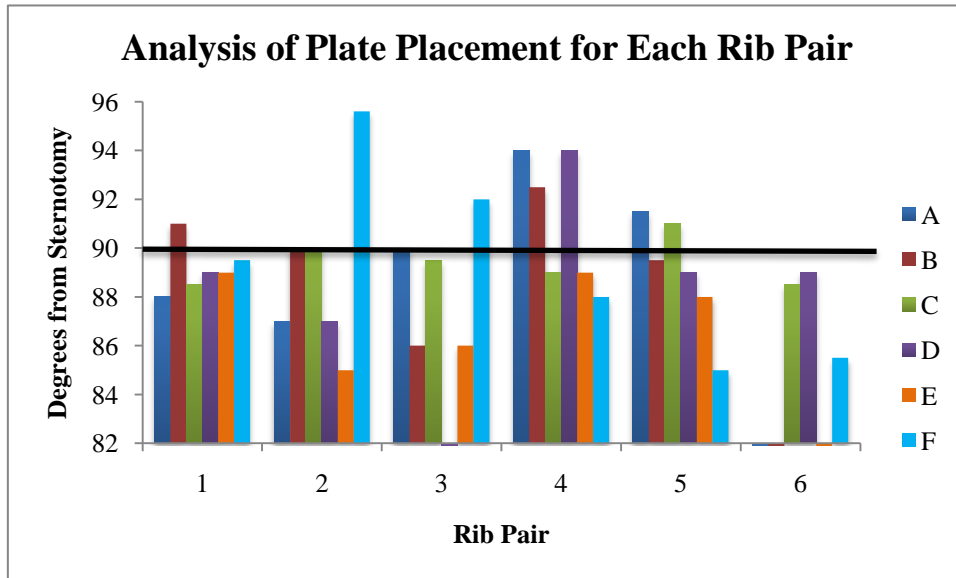

Figure 43: Plate placement for each rib pair independent of the types of plates and screws applied. 90° is the ideal angle of the plate from the sternal cut.

For all the rib pairs, the plates were placed within at least 5.0° of 90°. Rib pair 1 had the most consistency with plate placement with all plates being within at least 2.0° of 90°. This was surprising because, as previously mentioned, the first rib pair is the most obscurely shaped, so it would be expected that the plates would be placed less desirable. Additionally, the plate placement for all other rib pairs was extremely variable. It seems that plate placement is not really affected by the shape of the rib pair. Therefore, poor plate placement is most likely a result of plate and screw type, as well as human error during application.

The last individual rib pair analysis conducted from the pre-testing measurements was plate looseness. A summary of this analysis can be seen in Figure 44.

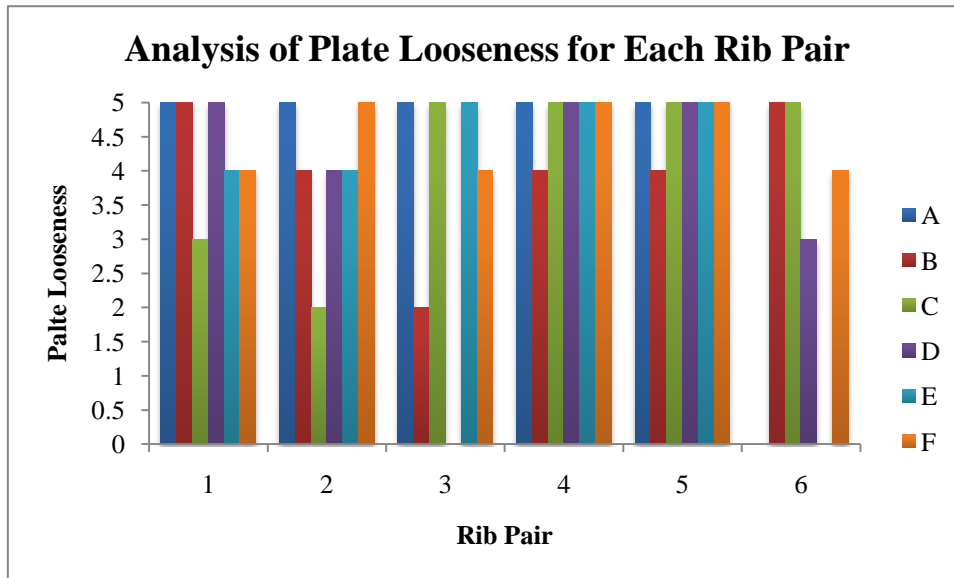

Figure 44: Looseness of the bone/plate/screw system independent of the types of plates and screws applied. A rank of 5 is very rigid and a 1 means that the system fell apart.

Plates applied to rib pairs 4 and 5 were the most rigid, receiving rankings of fours and fives. Rib pair 4 always had centered and contoured plates, so this rigidity could be a result of these factors; however, while rib pair 5 had several centered plates, most of them were not contoured. Rib pair 1 also received all fours and fives with the exception of one three. All of the plates applied to rib pair 1 were centered, but most were not contoured. Based on these rib pairs, it seems that centering may cause the systems to be more rigid. This centering-rigidity relationship is consistent with the findings from the individual sternum analyses. Since contouring seems to vary based on rib pair shape, its relation to rigidity is inconclusive. Additionally, there does not seem to be a correlation between plate placement and rigidity. The cause of the variability in rigidity for rib pairs 2, 3, and 6 are likely a result of the types of plates and screws that were applied to them.

---

#### 4.1.3 COMPARATIVE ANALYSES OF DIFFERENT FIXATION SYSTEMS

The analyses of pre-testing measurements in respect to the different types of plates and screws used were three-fold because three hypotheses were considered in this report. First, unicortical versus bicortical screw configurations were considered. Then, different screw diameters of 2.0 mm, 2.3 mm, and 2.7 mm, were considered. Lastly, three different plate types were considered: standard, locking, and compression. These analyses are beneficial to see the trends in ease of application as well as initial rigidity of different plate and screw types. All four analyses types discussed in the previous sections (plate centering, plate contouring, plate placement, and looseness) were conducted in this section as well. Note that because of the varied required sample sizes for different tests, the number of rib pairs analyzed throughout this section also varies.

The first pre-testing analysis for screw types was for unicortical and bicortical screw configurations. Unicortical and bicortical configurations were compared regarding plate centering, plate contouring, plate placement, and looseness. Figure 45 - Figure 48 summarize all of these comparisons.

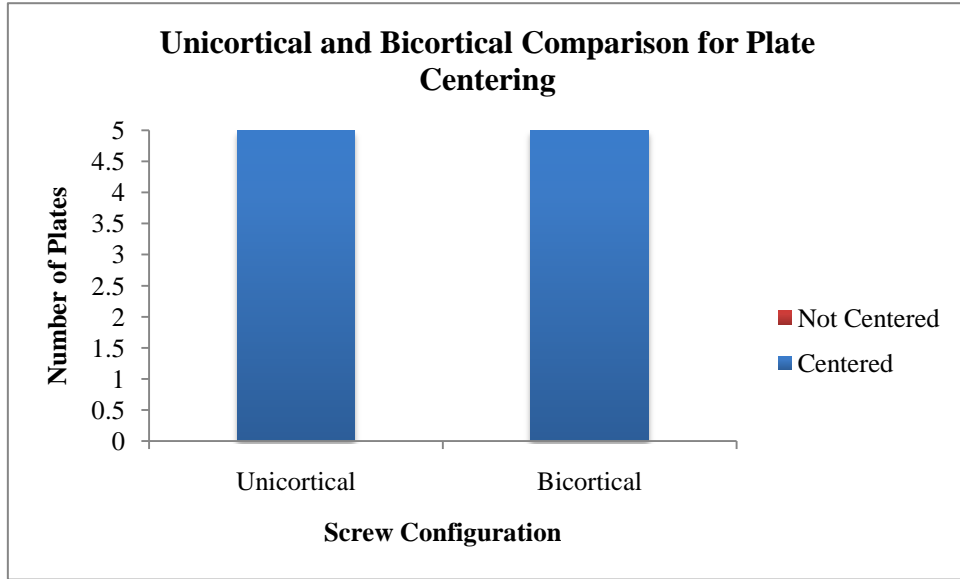

Figure 45: Comparison of plate centering for unicortical and bicortical configurations

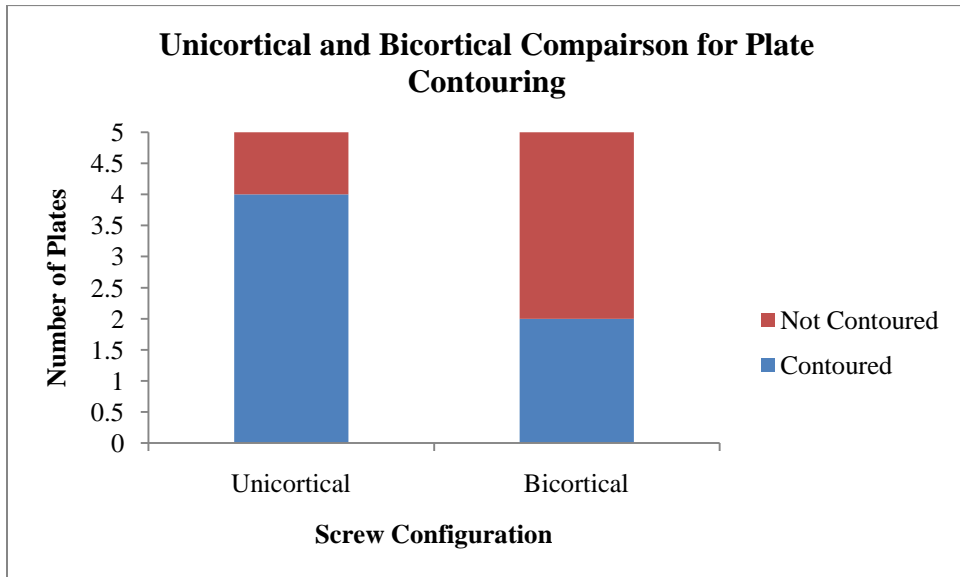

Figure 46: Comparison of plate contouring for unicortical and bicortical configurations

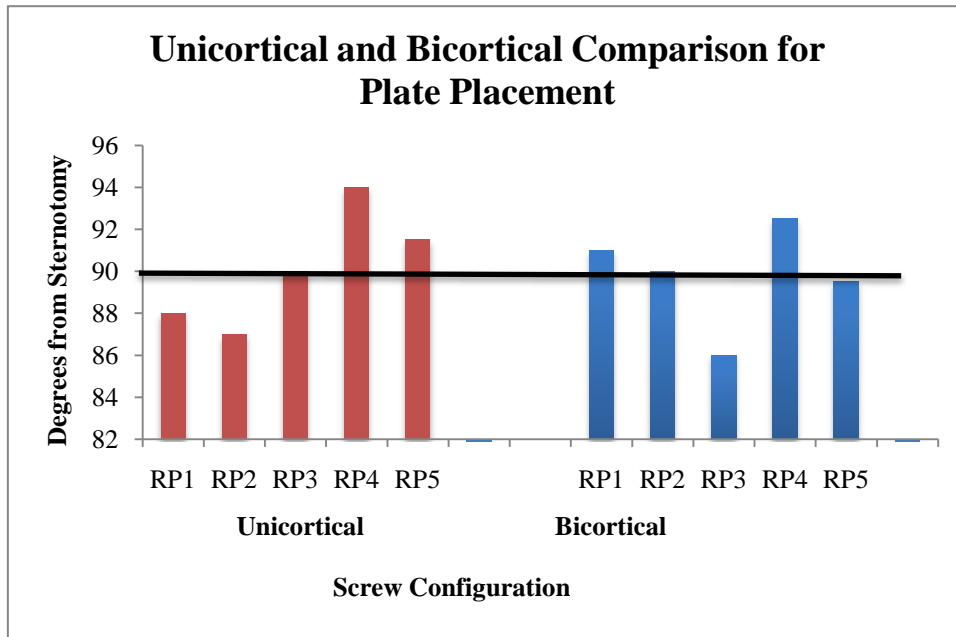

Figure 47: Comparison of plate placement for unicortical and bicortical configurations. 90° is the ideal angle of the plate from the sternal cut.

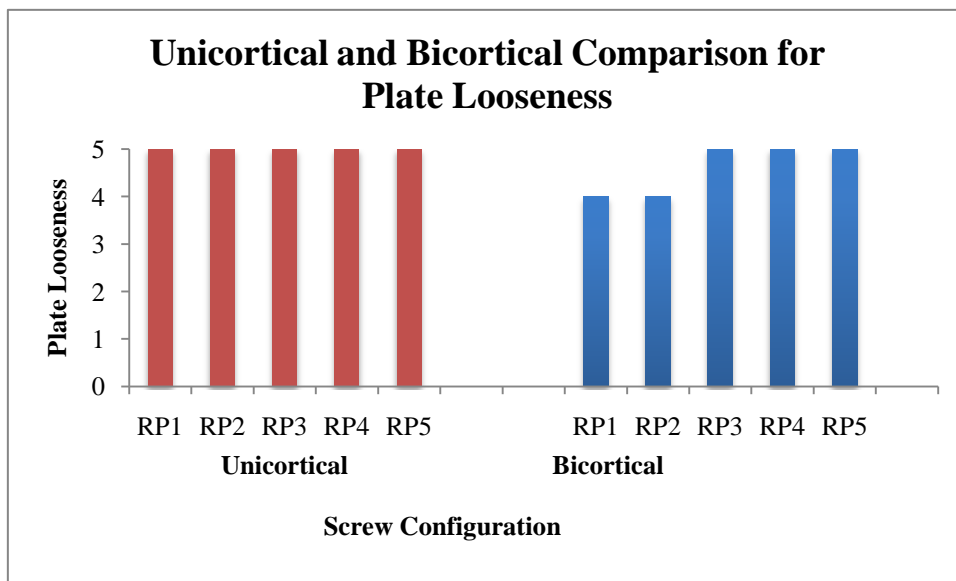

Figure 48: Comparison of the looseness of the bone/plate/screw system for unicortical and bicortical configurations. A rank of 5 is very rigid and a rank of 1 means the system fell apart.

All plates for unicortical and bicortical configurations were centered, but more plates were contoured for unicortical than for bicortical configurations. Contouring for these plates did not really matter in this case because the purpose of this testing was to evaluate different types of

screw configurations' abilities to improve rigidity. Plate centering was important in this case however because the fact that all of the plates were centered implies that these plate and screw types might be easier to apply. Similarly, plate placement was kept within 4.0° of 90.0°, and therefore it seems that these plates and screws were fairly easy to apply since their application was consistent and close to the desired angle. All of the plates for both unicortical and bicortical configurations were rigid as they were given only fours and fives for looseness. This rigidity is likely a culmination of the plate centering and plate placement, which was likely a result of the ease of application of these types of plates and screws.

The second pre-testing analysis for screw types was for different diameter screws. Screws with different diameters were compared regarding plate centering, plate contouring, plate placement, and looseness. Figure 49 - Figure 52 summarize all of these comparisons.

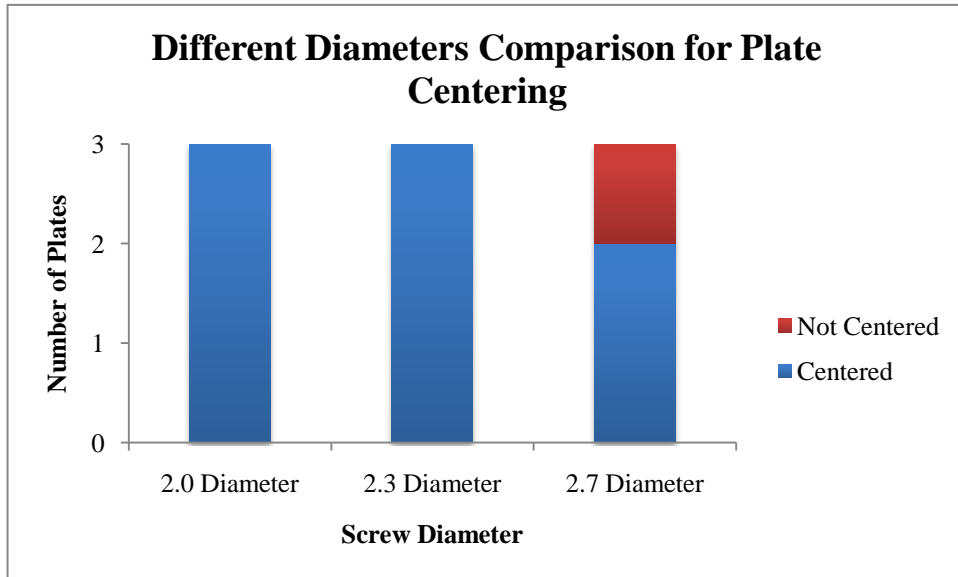

Figure 49: Comparison of plate centering for different diameter screws



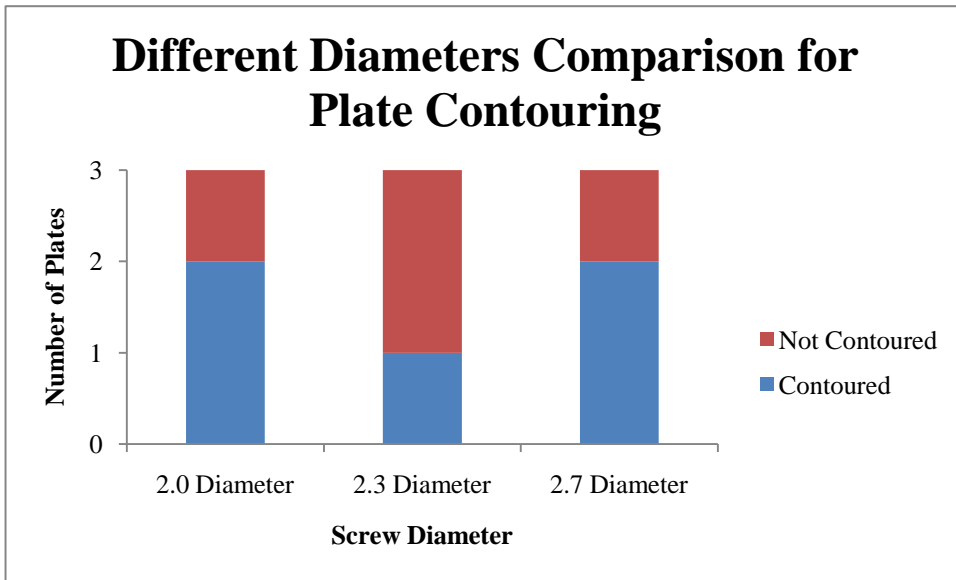

Figure 50: Comparison of plate contouring for different diameter screws

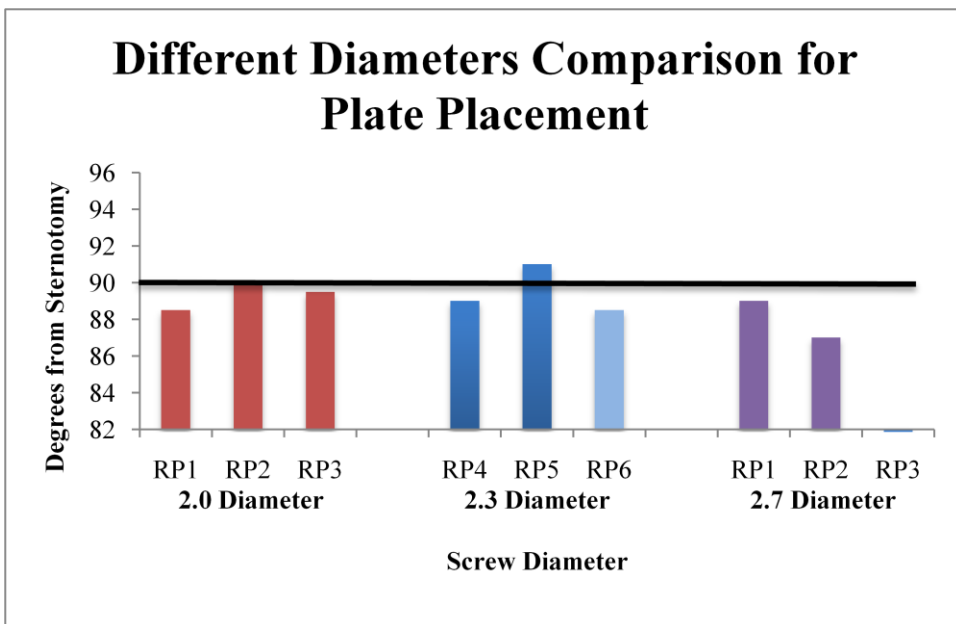

Figure 51: Comparison of plate placement for different diameter screws. 90° is the ideal angle of the plate from the sternal cut.

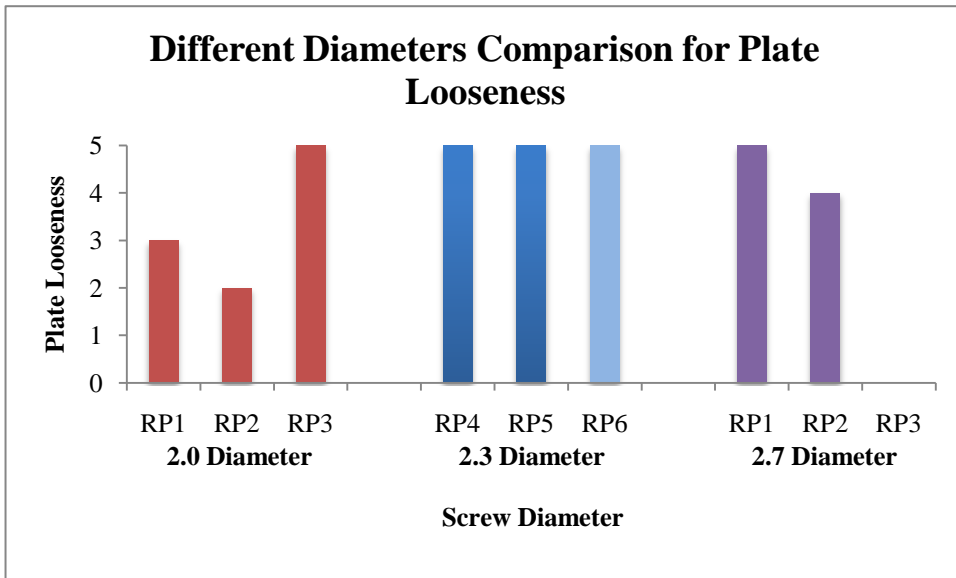

Figure 52: Comparison of the looseness of the bone/plate/screw system for different diameter screws. A rank of 5 is very rigid and a 1 means that the system fell apart.

The plates with 2.0 mm and 2.3 mm diameter screws were all centered while one plate was not centered for the 2.7 mm diameter screw. The 2.7 mm diameter screws had larger plates than the other two screw sizes, which may have made them more difficult to apply. As was the case with the unicortical and bicortical configurations analyses, the plate contouring really didn't matter for this analysis since the testing is looking at the screws' abilities to maintain rigidity. Contouring was varied for the three different diameters. Plate placement for the 2.0 mm and 2.3 mm diameter screws were both within 2.0° of 90.0°, and plate placement for the 2.7 mm diameter screws were within 3.0° of 90.0°. The third rib pair with 2.7 mm diameter screws fell apart prior to testing. The variability of plate placement and the fact that one rib pair fell apart prior to testing suggests that the 2.7 mm diameter screws might have been difficult to apply. This is consistent with the findings regarding plate centering. Lastly, the looseness for both the 2.0 mm and 2.7 mm diameter screws was extremely variable. This result implies that the 2.3 mm diameter screws were the easiest to apply to the rib pairs and are likely to produce the best results post-testing. This is consistent with the screw size that surgeons typically use in surgery.

The final pre-testing analysis was for different plate types. Standard, locking, and compression plates were compared regarding plate centering, plate contouring, plate placement, and looseness. Figure 53 - Figure 56 summarize all of these comparisons.

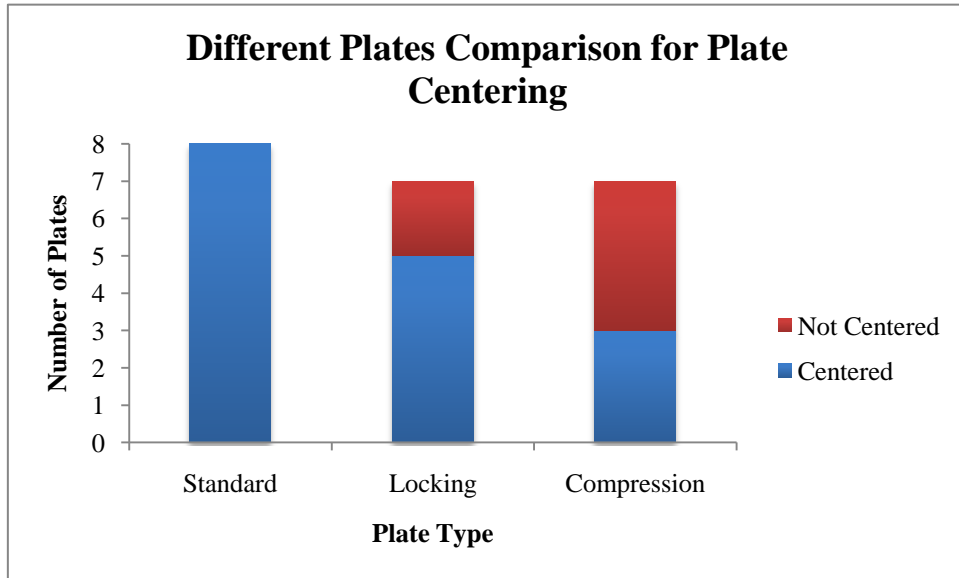

Figure 53: Comparison of plate centering for different plate types

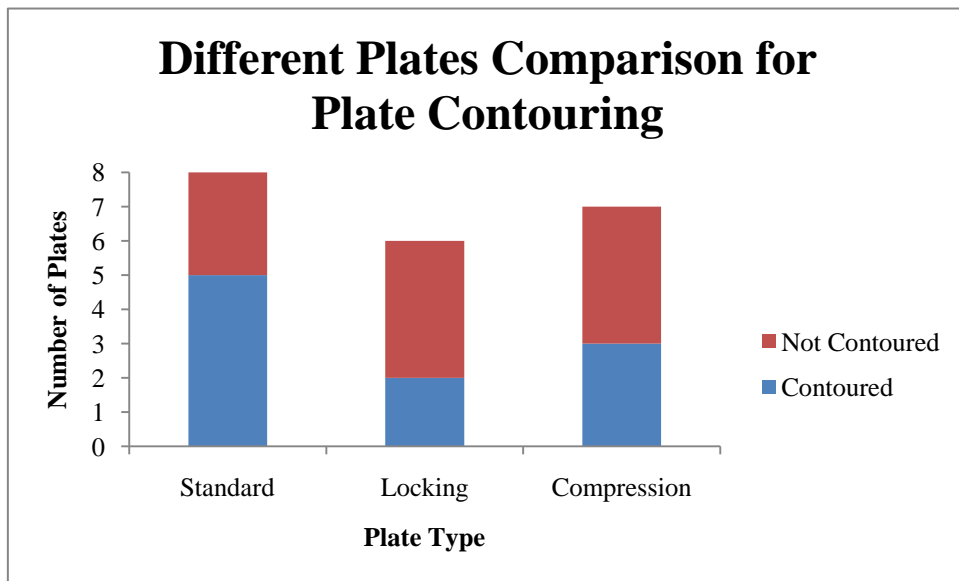

Figure 54: Comparison of plate contouring for different plate types.

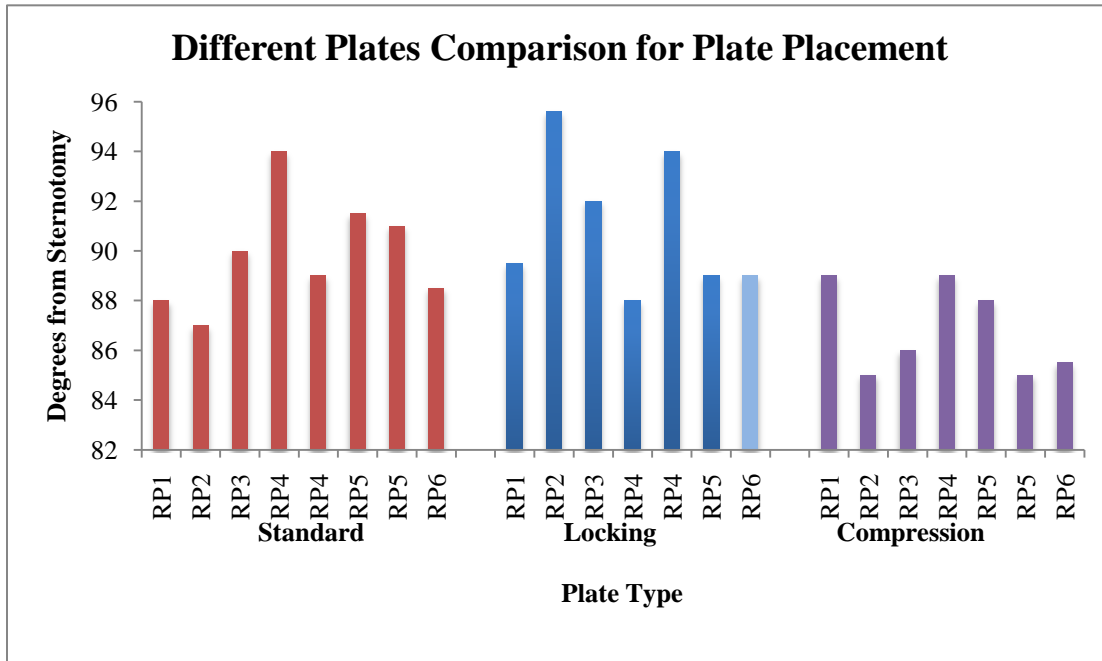

Figure 55: Comparison of plate placement for different plate types. 90° is the ideal angle from the plate to the sternal cut.

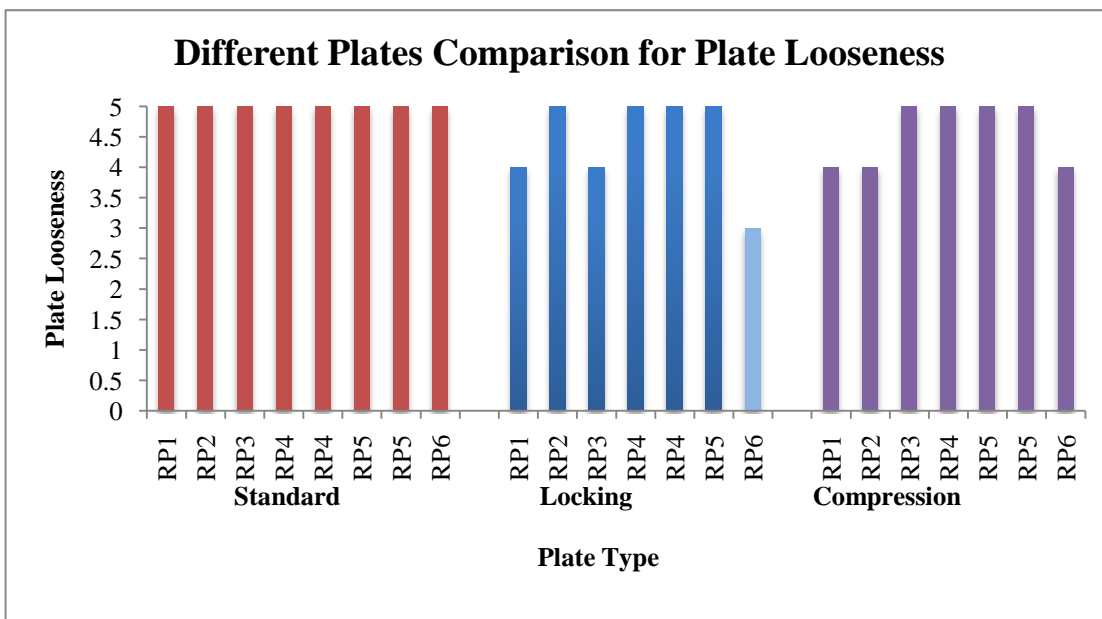

Figure 56: Comparison of the looseness of the bone/plate/screw system for different plate types. A rank of 1 is very rigid and a 5 means that the system fell apart.

All of the standard plates and most of the locking plates were centered, but only half of the compression plates were centered implying that they may have been more difficult to apply. Contouring for the three types of plates was extremely varied. Only two of the six locking plates

were contoured, but this is expected because locking plates are traditionally designed to not press against the bone. The varied contouring can also be explained by the previous findings from the individual rib pair analyses where it appeared that contouring was closely related to the shape of the rib pairs. Most of the standard and locking plates stayed within 2.0° of 90.0°. The plate placement of the compression plates, however, was much more varied with most of the plates 4.0° or more from 90.0°. This variability agrees with the results of the centering and suggests that the compression plates might have been more difficult to apply. Lastly, all of the three plate types were ranked fours and fives for looseness with the exception of one locking plate that was given a three. The standard plates all received fives for rankings, further demonstrating that these plates were easy to apply and as a result of being applied in a desirable way, they were also more rigid. It is interesting that despite the inconsistency of application, the compression plates still created rigid systems.

The results from the pre-testing measurements analyses are extensive and are a useful tool in understanding the reasoning behind setup failures that occurred prior to or during testing that were not a result of fixation failure. Additionally, they will be useful to determine tolerances for rigid sternal fixation systems.

#### 4.2 PRE-TESTING RESULTS FOR ALL TESTS

Upon completion of all testing, the following results were found pertaining to hardware application. Based on results from the first set of testing, it was decided that only plate centering and contouring would be analyzed for all samples. For this series of analyses, both centering of the plate horizontally and vertically on the rib pairs were considered. A similar series of analyses were followed to those for the first set of testing, where centering and contouring were

considered in relation to rib pair and fixation system type. An additional series of analyses was conducted to determine the relationship between these pre-testing measurements and setup failure rates.

#### 4.2.1 COMPARATIVE ANALYSES OF INDIVIDUAL RIB PAIRS

The first set of analyses conducted using the full set of pre-testing measurements is between each individual rib pair independent of the types of plates and screws applied. This first set of analyses continues the previous series from the first set of data to determine any correlation of rib pair size and shape with centering and contouring.

The first measurement considered was vertical plate centering. Vertical centering was evaluated by visual inspection to determine if a plate with centered between the superior and inferior edges of the rib pair. The Figure 57 below shows the results of this analysis.

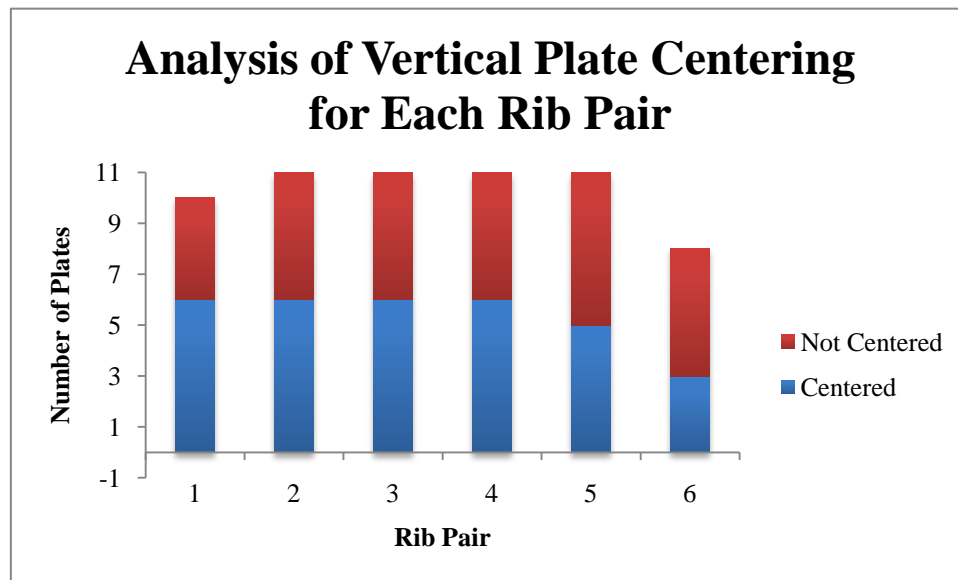

Figure 57: Analysis of vertical plate centering for each rib pair.

It does not appear that vertical plate centering is affected by the size or shape of a rib pair with the exception that rib pair 6, which is the xiphoid region, may be slightly more difficult to apply the plate vertically centered. It is likely that it is difficult to vertically center a plate on the 6<sup>th</sup> rib pair because it is larger in the vertical direction than other rib pairs. It may be difficult to determine where to place the plate especially since the xiphoid region is typically more cartilaginous than other rib pairs and usually the bonier portion is at the superior edge, and therefore the preferred location for plate placement. While polyurethane bone model was used in this testing, the residents were told to apply the plates as they would during surgery. This could be the reason that the vertical centering of the plates appears to be affected by the shape and size of rib pair 6.

The second measurement considered in this series of analyses is horizontal centering. This measurement was determined by measuring the horizontal distance of the left and right edges of the applied plate from the start of the left and right rib struts closest to that edge of the plate. This distance of the right rib pair was then divided from the left rib pair to determine the percentage difference of the two distances. If the percentage was within 20%, then the plate was considered to be horizontally centered. This analysis is useful to understand the relationship between horizontal centering and rib pair shape and size. The results from this analysis can be seen in Figure 58.

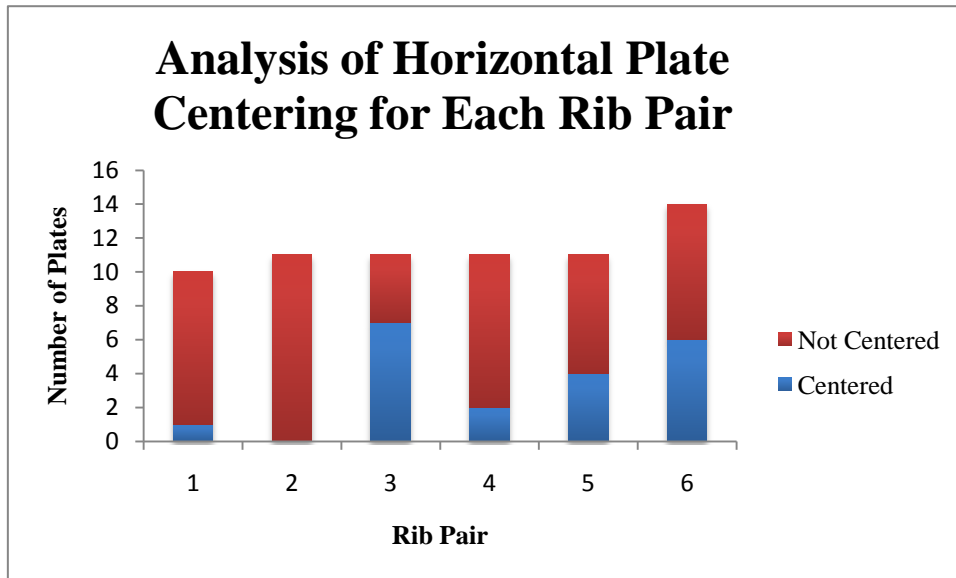

Figure 58: Analysis of horizontal plate centering for each rib pair.

There does not appear to be a correlation between horizontal plate centering and rib pair shape and size. Rib pairs 4 and 5 are the most simple and symmetrical in shape, which should make them easier to apply hardware to; however, they both have more plates not horizontally centered than centered. Rib pair 3 has the highest ratio of centered to not centered plates, which is understandable because it has a more symmetrical and flat shape similar to rib pairs 4 and 5. Despite this trend, there does not seem to be any correlation between horizontal plate centering and rib pair size and shape. It is more probable that horizontal plate centering is solely dependent on the person who applies the hardware.

The last measurement considered in this series of analyses is plate contouring. This analysis is useful to determine if plates tend to be contoured more frequently to certain rib pairs due to the shape of the rib pairs. Note that a plate is considered contoured if it fits with the rib pair even if it has not been manually bent to do so. The results from this analysis can be seen in Figure 59.



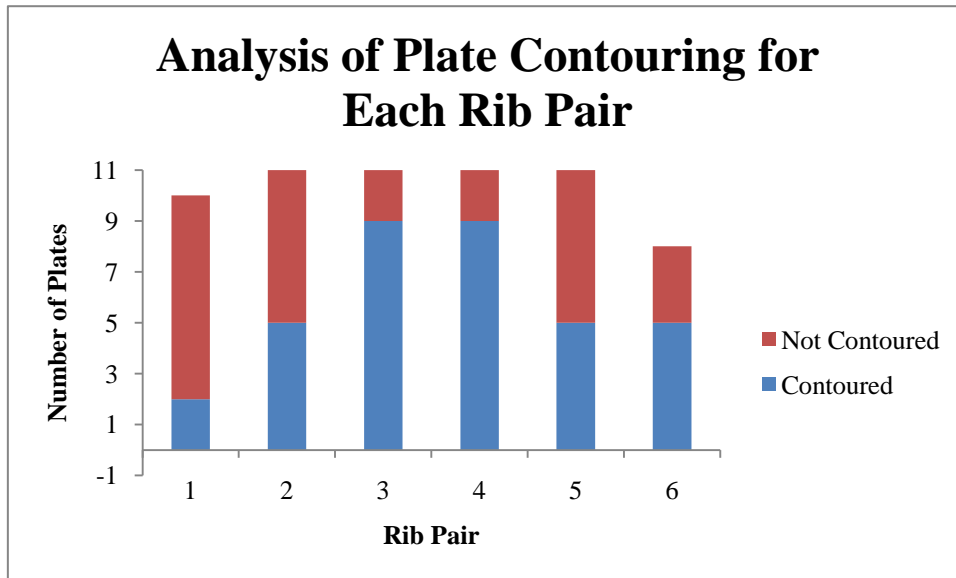

Figure 59: Analysis of plate contouring for each rib pair.

It is evident that plates tend to be contoured to rib pairs 3 and 4 more than any other rib pair. This is because these rib pairs are more flat in shape than most of the other rib pairs, and therefore little to no contouring is needed for a good fit. Additionally, rib pair 6 had a high ratio of contoured to not contoured plates. This trend is likely because the superior portion of rib pair 6 is considerably flat, and plates do not require much contouring in order to fit this rib pair. The trend from this analysis seems to be that plate contouring is usually a result of simpler, flatter rib pairs that happen to fit well with plates without actually being manually contoured.

---

#### 4.2.2 COMPARATIVE ANALYSES OF DIFFERENT FIXATION SYSTEMS

The second set of analyses conducted using the full set of pre-testing measurements is between different fixation systems. This second set of analyses continues the previous series from the first set of data to determine any correlation of unicortical and bicortical configurations, different screw diameters, and standard, locking, and compression systems with centering and

contouring. These analyses are useful to determine whether certain fixation types are easier to center or contour than others.

The first measurement considered in this series is vertical plate centering. The results from this analysis can be seen in Figure 60, Figure 61, and Figure 62.

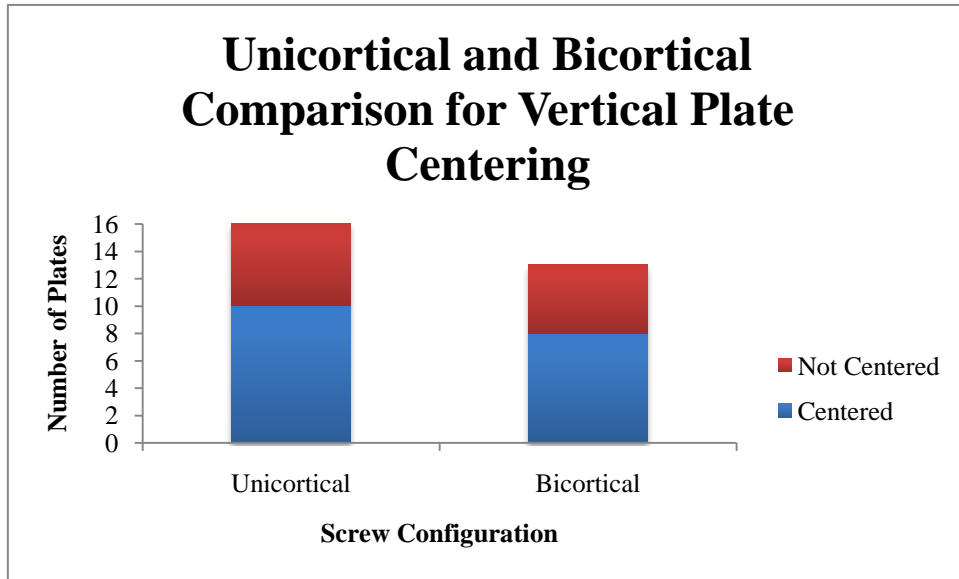

Figure 60: Comparison of unicotical and bicortical configurations with respect to vertical plate centering.

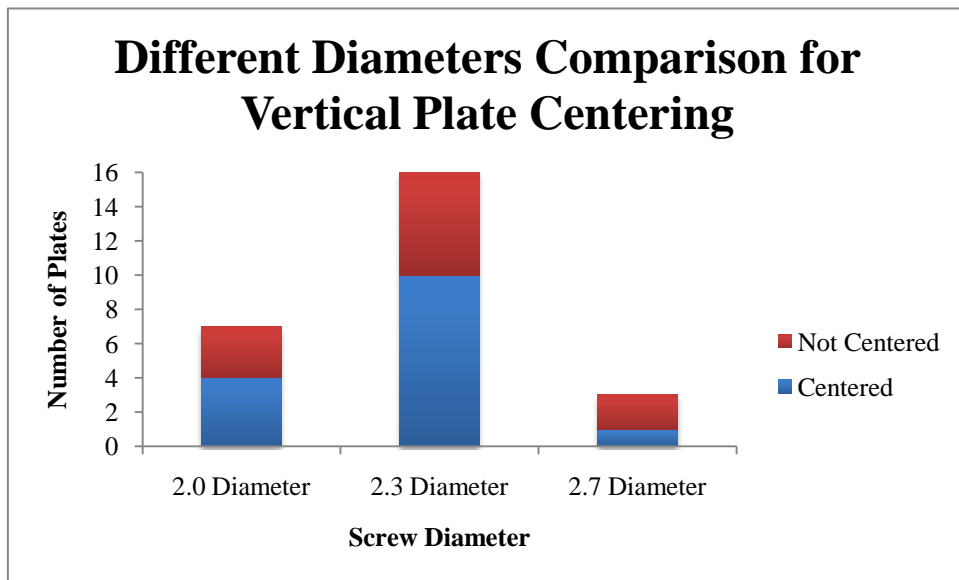

Figure 61: Comparison of different diameter screws with respect to vertical plate centering.

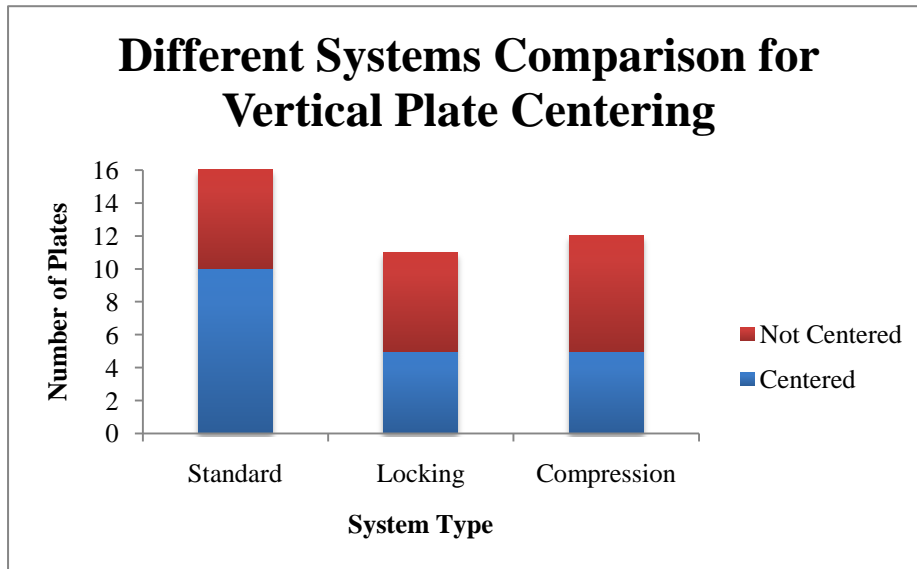

Figure 62: Comparison of different fixation systems with respect to vertical plate centering.

Despite the varying sample sizes, it appears that unicortical and bicortical configurations, 2.0 mm and 2.3 mm diameter screws, and standard fixation systems all have a larger number of plates that are vertically centered than not centered. This data could imply that these systems are easier to apply; however, all of these systems, with the exception of unicortical configuration and 2.0 mm diameter screws, are currently the standard used in clinical procedures. Additionally, the clients have mentioned that unicortical configurations can be easier to apply because there is less concern of piercing through the sternum. It seems that the results from this analysis are that certain fixation systems are more easily applied than others due to prior experience of applying them.

The second measurement considered in this series of analyses is horizontal plate centering. The results from this analysis can be seen in Figure 63, Figure 64, and Figure 65.

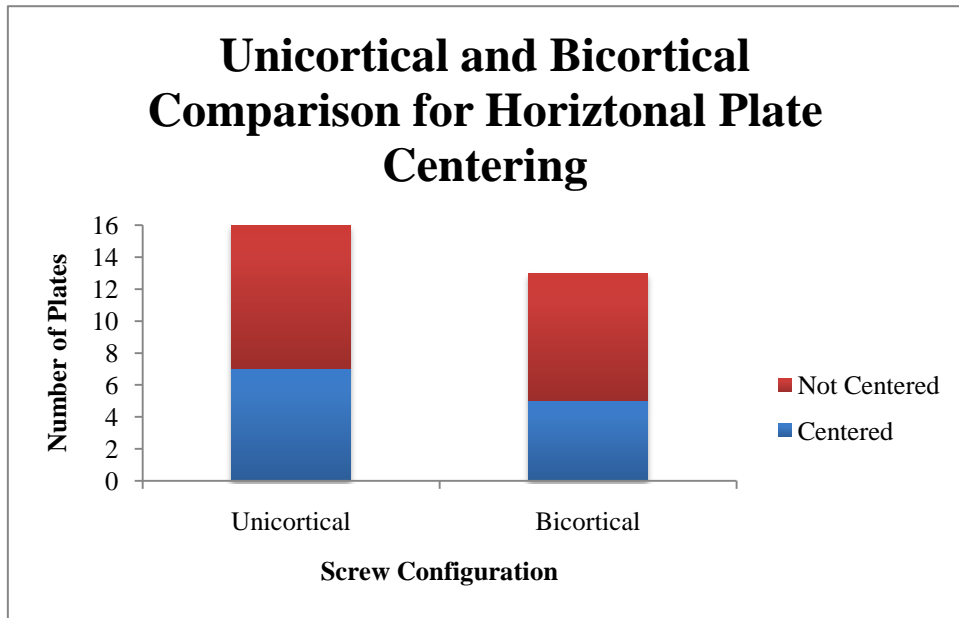

Figure 63: Comparison of unicortical and bicortical configurations with respect to horizontal plate centering.

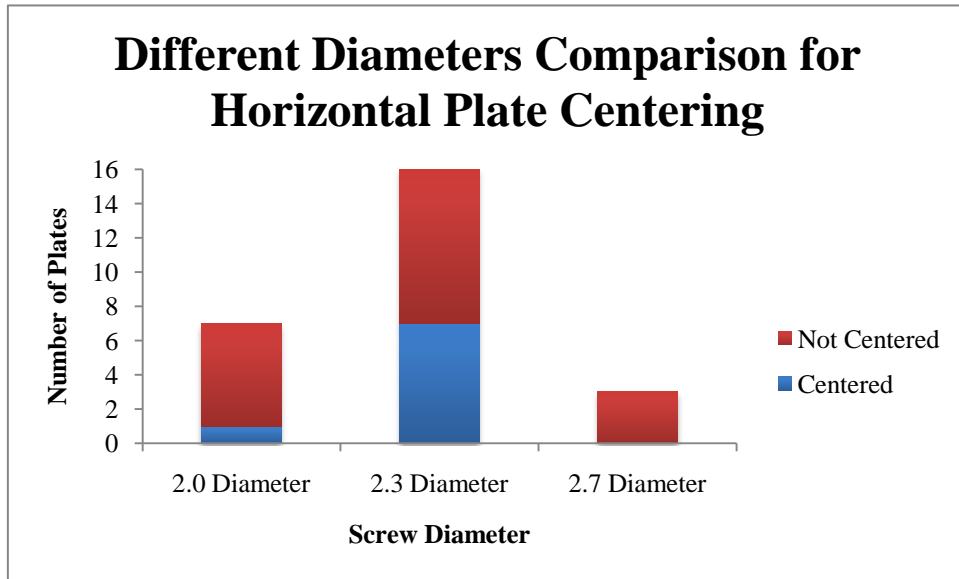

Figure 64: Comparison of different diameter screws with respect to horizontal plate centering.

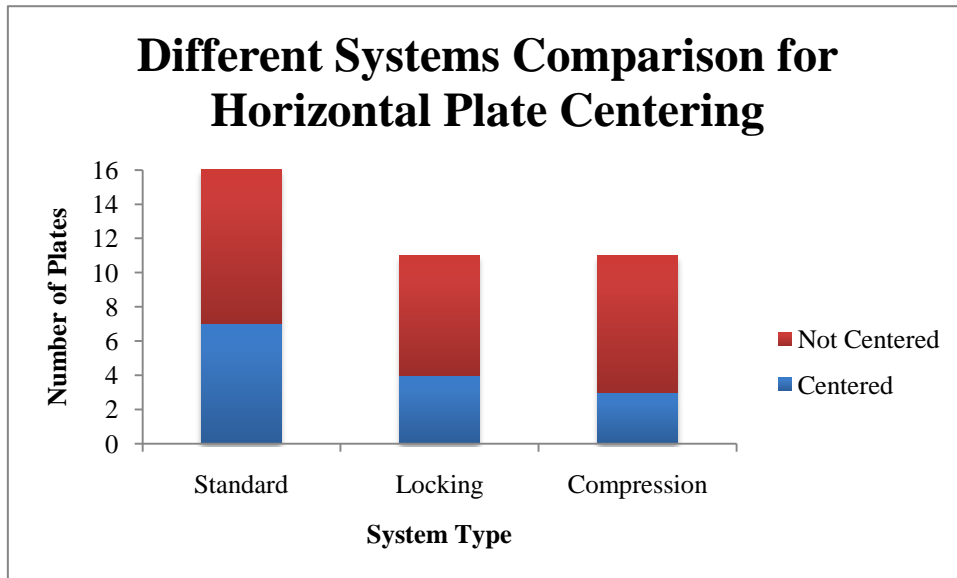

Figure 65: Comparison of different fixation systems with respect to horizontal plate centering.

There does not appear to be any correlation between horizontal plate centering and the type of fixation system. While some of the systems had more horizontally centered plates than others, none of the systems had a higher ratio of centered to not centered plates. The systems that had more horizontally centered plates than others were almost identical to the findings for vertically centered plates: unicortical and bicortical configurations, 2.3 mm diameter screws, and standard systems. This data seems to reiterate the fact that application relies more on experience with certain fixation systems.

The last measurement considered for this series of analyses is plate contouring. Only one graph is needed for this part of the analysis because contouring can only occur on plates, and while different configurations and screw diameters are used with plates, they are not contoured themselves. The graph displaying the results from this analysis can be seen in Figure 66.

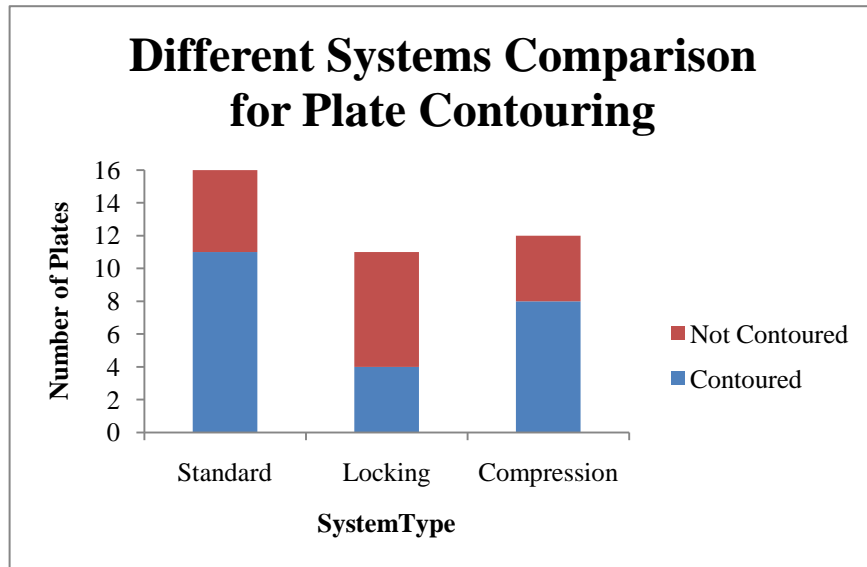

Figure 66: Comparison of different fixation systems with respect to plate contouring.

From this graph, standard and compression fixation systems are contoured more than not contoured. This is expected because locking plates are not intended to tightly fit the rib pair like standard and compression plates are. The few locking plates that are contoured are a result of the shape of the rib pair and not manual contouring of the plate. The results of this analysis show that all three fixation systems are being contoured appropriately according to their intended uses.

#### 4.2.3 CORRELATION OF PRE-TESTING MEASUREMENTS AND SETUP FAILURES

The final, and perhaps most important, analysis conducted using the pre-testing measurements was to determine the correlation of these measurements to the setup failures that occurred prior to or during testing. There were a total of 31 setup failures. Each pre-testing measurement was analyzed for each failure to determine the rates at which each pre-testing measurement coincided with a failure. The results of this analysis can be seen in Figure 67.

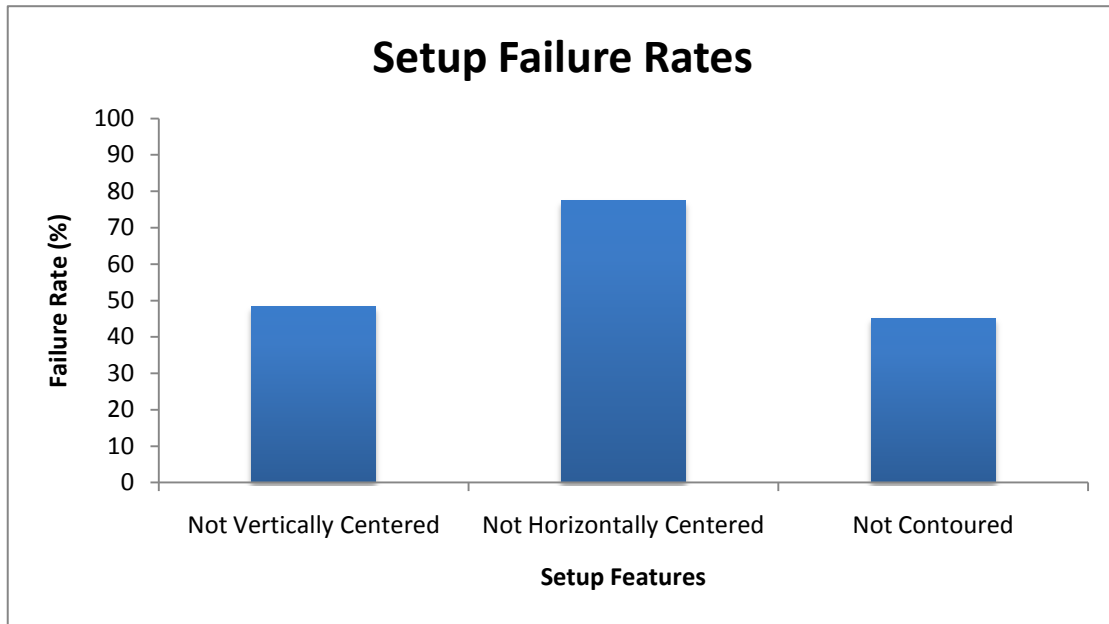

Figure 67: Setup failure rates with respect to different setup features.

Seventy-seven percent of all failures were systems that were not horizontally centered. It is evident that this setup feature plays an important role in the success of a sample to complete testing. The other two setup features resulted in less than fifty percent of failures, which seems to show that vertical centering and contouring are not as much of a concern as horizontal centering during hardware application.

The series of analyses conducted from the pre-testing measurements are useful to understand the importance of careful hardware application in order to prevent setup failures. Ultimately, with more extensive research, tolerances can be determined in order to optimize rigid fixation system placement on the sternum.

#### 4.3 POST-TESTING DATA RESULTS OF IMAGE PROCESSING

Pictures were taken prior to and after testing and analyzed through ImageJ in attempts to measure dehiscence and splay. Each sample was measured by drawing a line connecting the centroid of the superior and inferior dots. The amount of anterior dehiscence and posterior splay will reveal how well the plate types, screw configurations, and varying screw diameters will affect the success of the system. These results are useful to evaluate and characterize an optimal screw-plating system that will be able to prevent malunion and fosters bony in growth for osteoporotic bone.

Samples not included had resulted in failure due to Instron malfunctions, screw pullout, or a break in the polyurethane bone model. The failures were expected due to the low density characteristics exhibited by the polyurethane bone models chosen for this experiment. The negative splay and dehiscence values are present when there is an increased displacement but are compensated when compressed on the opposite side. Figure 68 is a representation of an increased amount of splay causing compression on the posterior side of the sample.



Figure 68: Side view of a sample with an increased amount of splay



The negative values are also caused by an increased amount of distance on either the superior or inferior ends, compensated with a compression on the opposite side. This is illustrated in Figure 69, where the one side's gap widens while the other side's compresses.

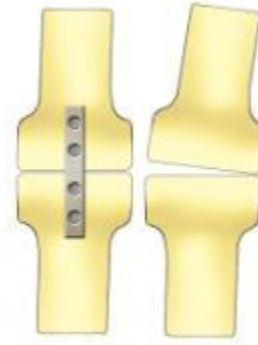

Figure 69: Frontal view of a sample with a considerable gap on one side

Although pictures were taken prior to and after testing, the first half of the images were not considered since the Bluehill program had reset the gauge length to its initial position after the set amount of cycles. Because of this, there was no difference to be seen when the Instron machine reset to the initial starting position. The second batches of images were corrected but there were only a limited amount of samples that could be analyzed using the ImageJ software to calculate the dehiscence and splay values. The second batch of images included six unicortical and six bicortical configuration screws as seen in Figure 70 and Figure 71.

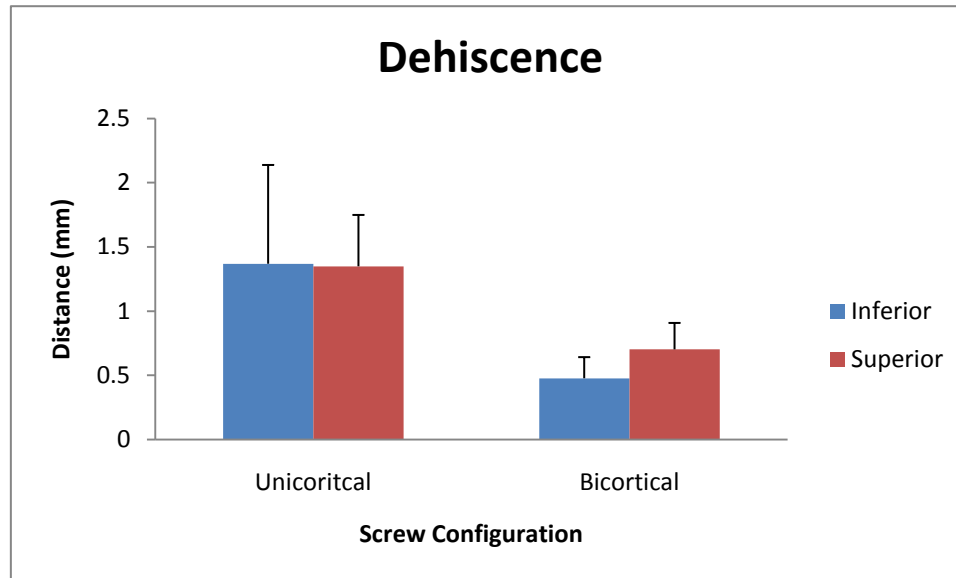

Figure 70: Anterior dehiscence using the ImageJ analysis

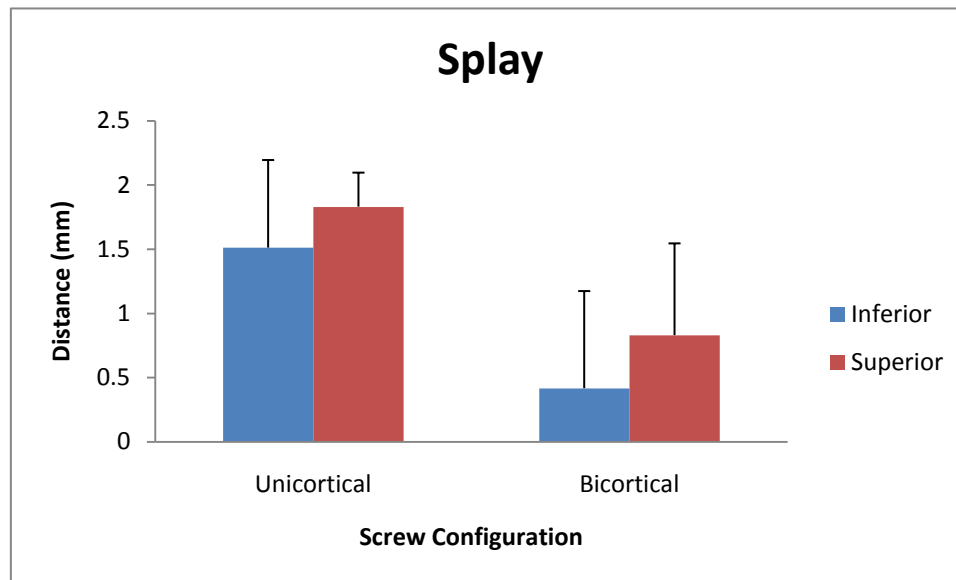

Figure 71: Posterior splay using the ImageJ analysis

Although one can infer from Figure 70 and Figure 71 that the bicortical screws performed better than the unicortical screws for anterior dehiscence and posterior splay, the ImageJ analysis was discarded due to various factors that may have influenced the data. None of the results were

statistically different and each had a high standard deviation. Additional comparisons between the ImageJ analysis and displacement values output by the Instron machine did not match. The distance per pixel measured had varied due to varying positions of the camera and calibration ruler which had skewed the data for each picture. As mentioned previously, when the loads were initially applied to the polyurethane bone models, the hysteresis was not held accountable during the ImageJ analysis. There are several ways to assess and address these issues for an optimal experiment to measure anterior dehiscence and posterior splay.

In order to utilize the calibration ruler efficiently, the calibration ruler must be placed at a set position on the plane of the sample. If the placement of the ruler is offset, then the amount of pixels per distance will vary accordingly. If one can place tick marks on the fixture of a known distance, consistent placement of the calibration ruler would be ensured. In order to compensate for the hysteresis values onto the ImageJ values, the pictures could be taken after a few cycles for the screws to settle into the bone. A real-time video can also be used to document the displacement over time.

One needs to take into consideration various factors for ImageJ analysis when utilizing cadaveric sternum tissue for the experiments. The dots cannot be used because they are covered by the gauze, and the phosphate buffered saline (PBS) used to keep the sample hydrated may run the ink off of the sternum. Alternatively, an extensometer can be used in order to track changes in dehiscence and splay.

## 4.4 POST-TESTING ANALYSIS OF BONE SEPARATION AND SCREW LOOSENING

### 4.4.1 HYPOTHESIS 1: BONE/ SCREW INTERFACE

#### UNICORTICAL VS. BICORTICAL CONFIGURATION

Hypothesis 1 was focusing on the bone/screw interface analysis. The first part of this hypothesis was designed to evaluate the effect of unicortical and bicortical configurations. This was achieved by measuring the bone separation using the raw data collected from the Instron load cell measurements, and the screw loosening data collected for the size of each screw hole. The total number of samples that were needed for each group according to the power analysis was 13 samples per group. Two samples of each group did not finish testing. From the rest only one unicortical and one bicortical samples had bone separation greater than 2 mm. After discarding the setup failure test samples there were 10 per group that were used for data analysis. As shown in Table 9 the mean for bone separation of all unicortical samples (n=10) is 1.15 mm, SD 0.87, whereas the mean for all bicortical samples (n=10) is 1.16 mm, SD 1.21.

Table 9: Average Bone Separation Data for unicortical vs. bicortical configurations

|                      | Unicortical | Bicortical |
|----------------------|-------------|------------|
| # of samples tested  | 13          | 13         |
| # of samples pass    | 10          | 10         |
| Bone separation [mm] | 1.15        | 1.16       |
| Standard Deviation   | 0.87        | 1.21       |

Even though the bicortical configuration had smaller separation it had higher standard deviation compared to unicortical (Figure 72). Performing ANOVA Single Factor analysis with

$p < 0.05$  for this part of the hypothesis shows p-value of 0.98. This demonstrated that there is no statistically significant difference between the two groups, therefore unicortical and bicortical configurations were comparable in fixation performance.

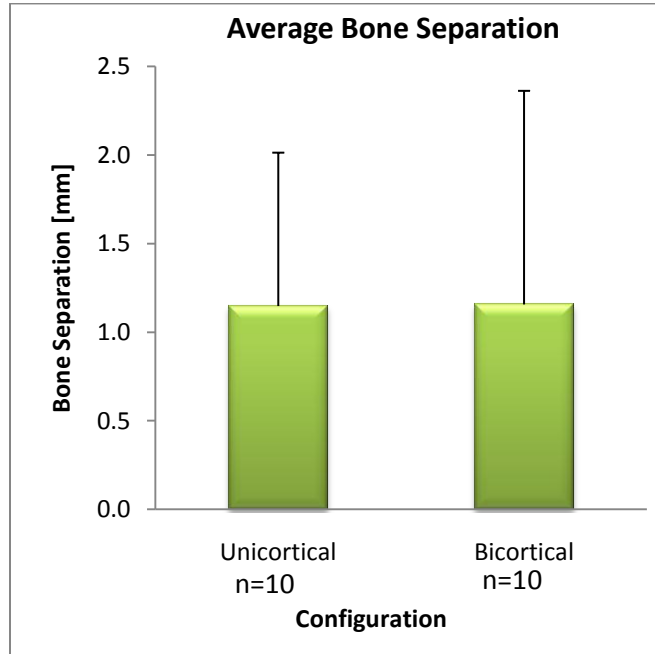

Figure 72: Average Bone Separation Analysis for unicortical vs. bicortical configurations

This result was confirmed with the screw loosening data analysis showing comparable performance of the unicortical and bicortical configurations. As shown in Table 10 the average screw loosening for unicortical configuration (n=10) was 31%, SD 8.0, whereas for bicortical it was 26%, SD 12.7.

Table 10: Percent screw loosening data for unicortical vs. bicortical configurations

|                     | Unicortical | Bicortical |
|---------------------|-------------|------------|
| # of samples tested | 13          | 13         |
| # of samples pass   | 10          | 10         |
| Screw Loosening [%] | 31          | 26         |
| Standard Deviation  | 8.0         | 12.7       |

Even though the bicortical screw loosening was lower than the unicortical (Figure 73), it was found to be a not statistically significant difference between the 2 groups based on the ANOVA analysis with a p-value of 0.31.

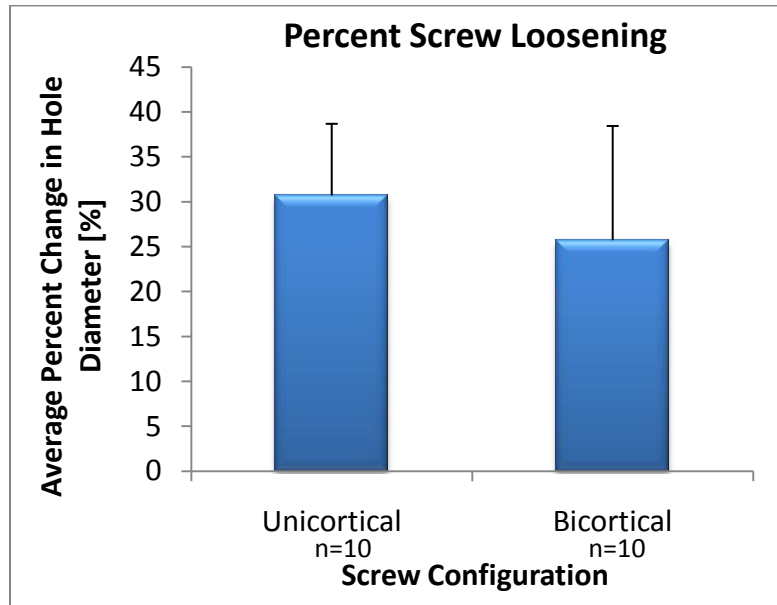

Figure 73: Percent screw loosening Analysis for unicortical vs. bicortical configurations

The team decided to continue further testing on cadaveric sternum for two major reasons: the obtained data from the low density polyurethane sternal models was consistent with previous research, and the fact that the polyurethane models have uniform density and there is a lack of cortical layers. The sternum was provided by the surgeons at UMMS and the hardware was applied by Dr. Dunn. The validation was focused on unicortical and bicortical configurations; therefore, three samples of each were assembled. Reference Appendix Q - Full Protocol for complete protocol of the testing parameters.

The average bone separation results are presented in Table 11. Out of 3 samples attempted for both groups all unicortical configurations successfully completed testing, but the

bicortical samples had one setup failure in which the sample became loose at the beginning of the test. This was a result of the screws in the anatomical left rib, which were pulling out of the bone while testing and this made the load cell exceed the programmed limits. This sample was discarded from the data analysis. The unicortical configuration had average bone separation of 1.43 mm, SD 0.36, whereas the bicortical one had 3.46 mm, SD 0.25.

**Table 11: Comparison of unicortical vs. bicortical configurations from cadaveric testing**

|                      | Unicortical | Bicortical |
|----------------------|-------------|------------|
| # of samples tested  | 3           | 3          |
| # of samples pass    | 3           | 2          |
| Bone separation [mm] | 1.43        | 3.46       |
| Standard Deviation   | 0.36        | 0.25       |

The unicortical configuration was observed to minimize bone separation better than bicortical not only based on the average bone separation but also based on the failure rate. The bicortical configuration was found to violate the major constraint of the project – separation between the sternal halves less than 2 mm (Figure 74). Performing ANOVA analysis with significance level of 0.05 showed that the difference between the two groups was statistically significant due to the p-value of 0.01. Therefore, unicortical configuration was shown to perform better than bicortical configuration as per cadaveric testing.

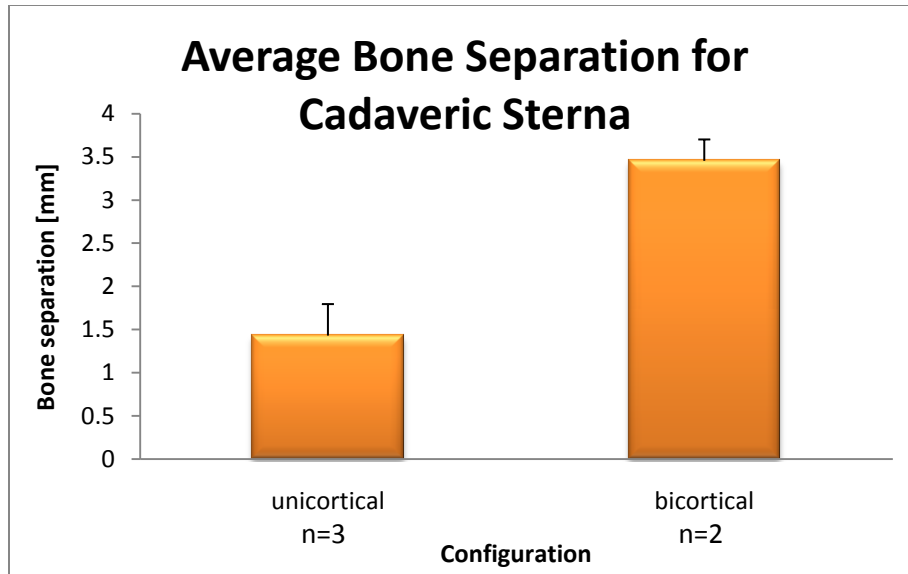

Figure 74: comparison between unicortical and bicortical configuration based on cadaveric sternal testing

#### MAJOR SCREW DIAMETER ANALYSIS

The second part of Hypothesis 1 was based on the analysis of different major screw diameters of cortical screws. The hardware used was standard plates with 2.0 mm and 2.3 mm major diameter screws, and compression plates with 2.7 mm major diameter screws. The first hardware assembly session was made on all 3 types of hardware including 3 samples of each. Since all 2.7 mm screw/plate systems failed early in the test they were excluded from further testing. The second hardware application session was intended to replace the setup failures from the first batch and to make a total of 6 samples for each group as described in the power analysis. 4 samples of the 2.0 mm system failed before completion of the test due to setup failure, so the total number of samples included in the data analysis was 2. Similarly, one of the 2.3 mm major diameter systems failed, so the total number for this group was 5. As shown in Table 12 the mean for bone separation of all 2.0 mm major screw diameter samples (n=2) is 1.33 mm, SD 0.01, whereas the mean for all 2.3 major screw diameter samples (n=5) is 0.83mm, SD 0.53.



Table 12: Average Bone Separation Data for different major diameter screws

|                      | 2.0 mm | 2.3 mm | 2.7 mm  |
|----------------------|--------|--------|---------|
| # of samples tested  | 6      | 6      | 3       |
| # of samples pass    | 2      | 5      | 0       |
| Bone separation [mm] | 1.33   | 0.83   | No Data |
| Standard Deviation   | 0.01   | 0.53   | No Data |

In addition to the lower bone separation it has to be noted that the success rate of the 2.3 mm screws was much higher than that of the 2.0 mm and 2.7 mm screws.

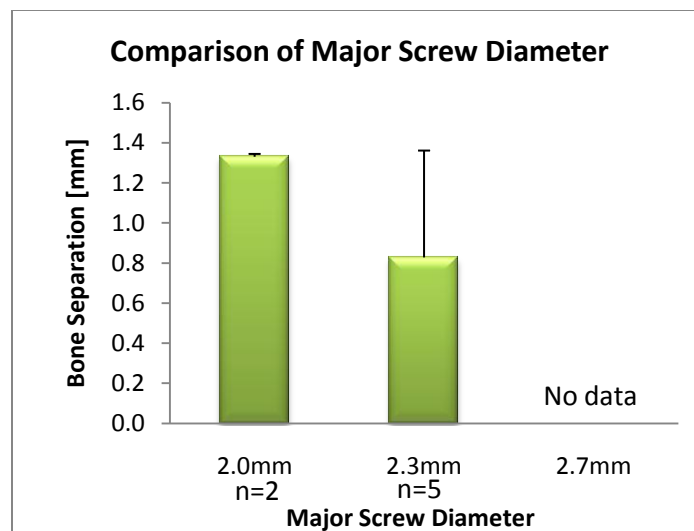

Figure 75: Comparison of bone separation for different major screw diameters

Performing ANOVA Single Factor analysis with  $p < 0.05$  for this part of the hypothesis shows p-value of 0.26. This demonstrated that there is no statistically significant difference between the groups, therefore 2.0 mm and 2.3 mm major diameter screws were comparable in fixation performance; however, there was a trend that the 2.3 mm screws were minimizing the bone separation to higher extent compared to the 2.0 mm and 2.7 mm screws.

The same trend was observed in the screw loosening analysis. As shown in Table 13 all 2.7 mm major diameter screws had no data because they all failed during testing. In addition, the 2.0 mm major diameter screws had screw loosening of 43%, SD 2.8, whereas the 2.3 mm screws had 31%, SD 14.4.

Table 13: Percent screw loosening data for different major diameter screws

|                     | 2.0 mm | 2.3 mm | 2.7 mm  |
|---------------------|--------|--------|---------|
| # of samples tested | 6      | 6      | 3       |
| # of samples pass   | 2      | 5      | 0       |
| Screw Loosening [%] | 43     | 31     | No Data |
| Standard Deviation  | 2.8    | 14.4   | No Data |

The 2.3 mm screws have smaller screw loosening compared to the 2.0 mm screws (Figure 76). However, this was not a statistically significant difference based on the ANOVA analysis with p-value equal to 0.08.

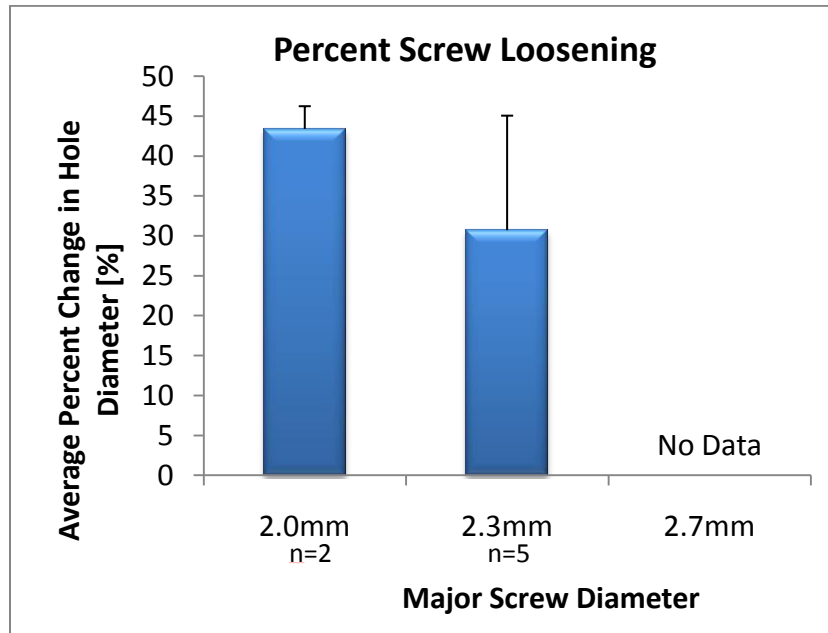

Figure 76: Comparison of percent screw loosening for different major screw diameters

#### 4.4.2 HYPOTHESIS 2: BONE/PLATE AND SCREW/PLATE INTERFACES

Hypothesis 2 was focusing on the bone/plate and screw plate interfaces for 3 fixation types: standard, locking, and compression. These were evaluated through bone separation and screw loosening analysis as well as bone/plate distance. The latter was evaluated based on a pass/fail analysis because measuring the exact distance between bone and plate was difficult with the instrumentation provided. Pass was defined as the distance between the bone and the plate being less than 2 mm. The total number of samples needed for each group based on the power analysis was 8. After testing the samples that failed due to setup failures and fixation failure were removed from the data analysis. The standard fixation system resulted in 2 setup failures; therefore, the total number of samples used was 6. Similarly, the locking system had 1 setup failure resulting in 7 samples for data analysis, and the compression system had 6 setup failures, so the total number of samples was reduced to 2. The average bone separation for standard plates (n=6) was 0.81 mm, SD 0.45. The average bone separation for compression system (n=2) was 0.93 mm, SD 0.2, and for locking (n=7) was 0.91 mm, SD 0.72 (Table 14).

Table 14: Average Bone Separation Data for different fixation systems

|                      | Standard | Compression | Locking |
|----------------------|----------|-------------|---------|
| # of samples tested  | 8        | 8           | 8       |
| # of samples pass    | 6        | 2           | 7       |
| Bone separation [mm] | 0.81     | 0.93        | 0.91    |
| Standard Deviation   | 0.45     | 0.20        | 0.72    |

Locking and standard fixation systems demonstrated lowest bone separation among the 3 fixation types tested. Even though the compression plates had the lowest standard deviation, they had also the highest failure rate.

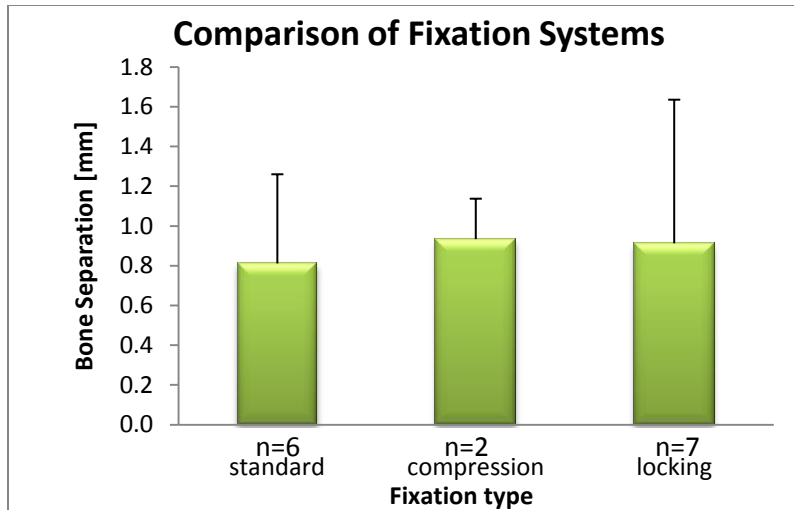

Figure 77: Comparison of average bone separation for different fixation systems

Performing ANOVA Single Factor analysis with  $p < 0.05$  for this part of the hypothesis shows p-value of 0.97. This demonstrated that there is no statistically significant difference between the groups, therefore standard, locking, and compression fixation systems were comparable in fixation performance; however, there was a trend that the standard and locking systems minimized the bone separation to higher extent compared to the compression systems.

The results from the bone separation analysis were also confirmed with the screw loosening data showing the same trend. In Table 15 the data for the 3 different fixations systems – standard, compression and locking – were shown to have 31%, SD 13.2, 63%, SD 26.5, and 40%, SD 20.1 respectively.

Table 15: Average screw loosening data for different fixation systems

|                     | Standard | Compression | Locking |
|---------------------|----------|-------------|---------|
| # of samples tested | 8        | 8           | 8       |
| # of samples pass   | 6        | 2           | 7       |
| Screw Loosening (%) | 31       | 63          | 40      |
| Standard Deviation  | 13.2     | 26.5        | 20.1    |

Even though the standard and the locking fixation systems were found to have less screw loosening compared to the compression (Figure 78) there was no statistically significant difference between the three groups because the p-value generated through the ANOVA analysis was 0.09.

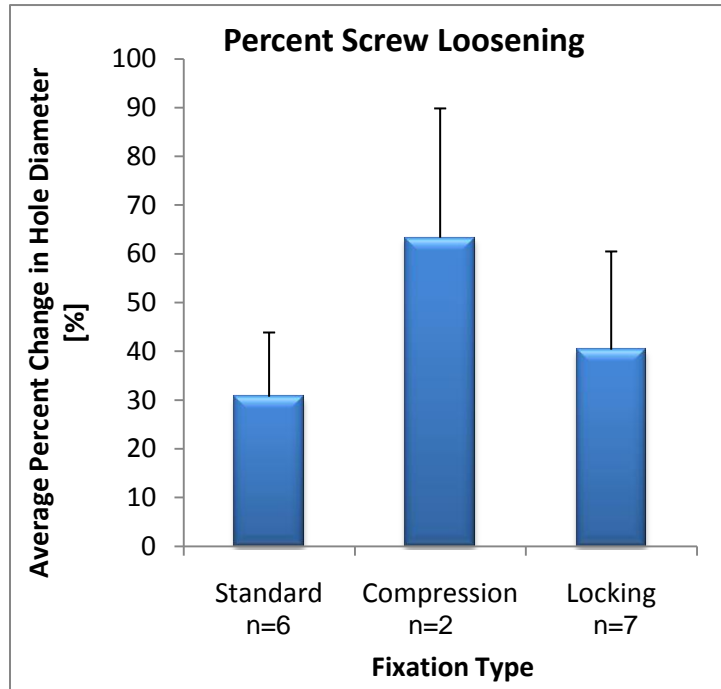

Figure 78: Comparison of percent screw loosening for different fixation systems

## 4.5 RESULTS OF COMPUTER SIMULATION

Models were generated with the Working Model 2D software. They were based on actual polyurethane samples. The first one was modeled as a straight plate that was placed perpendicular to the sternal cut and the loading is applied in line with the plate as shown in Figure 79. Each of the three sections of the plate was numbered with numbers from 1-3 in Figure 79. The average tension for sections 1 and 3 resulted in 0 N, whereas section 2 was found to be 50.5N. In terms of bone separation the total superior separation distance was 0.17 mm, and the inferior separation was 0.25 mm.

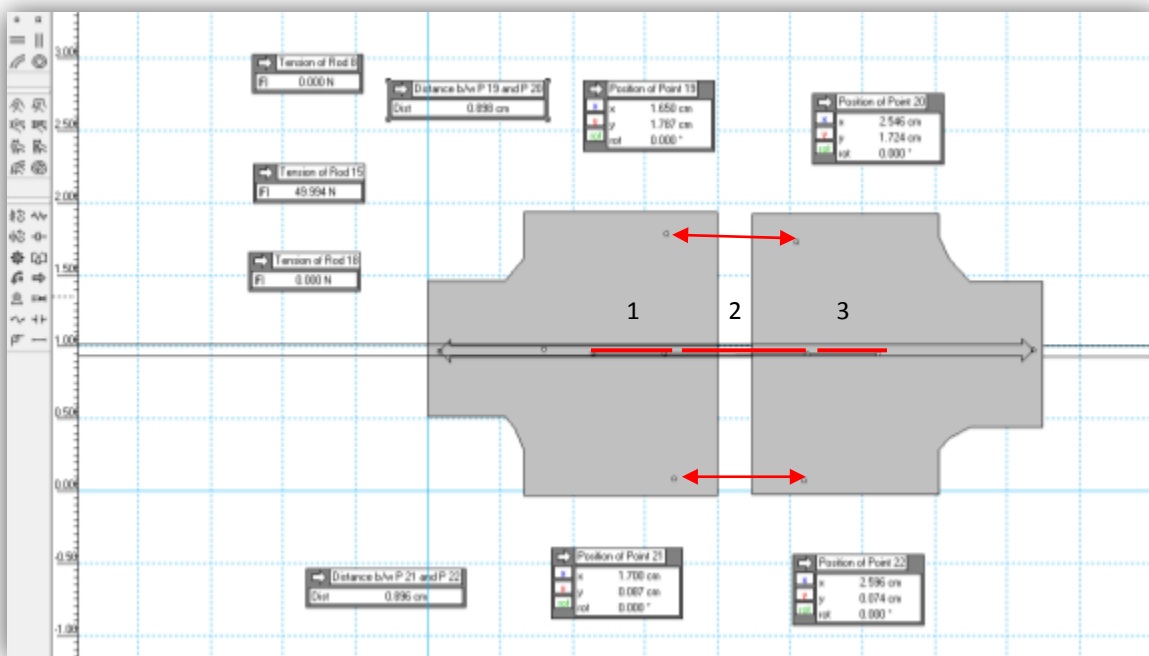

Figure 79: Working Model 2D - Model of a straight plate

The second model was developed as an offset plate placed above the line of the loading. The plate was still perpendicular to the sternotomy like in the previous case but the load on the plate and screws differs. The setup is shown in Figure 80 with red arrows denoting the measurements of the bone separation and red lines showing the 3 sections of the plate model.

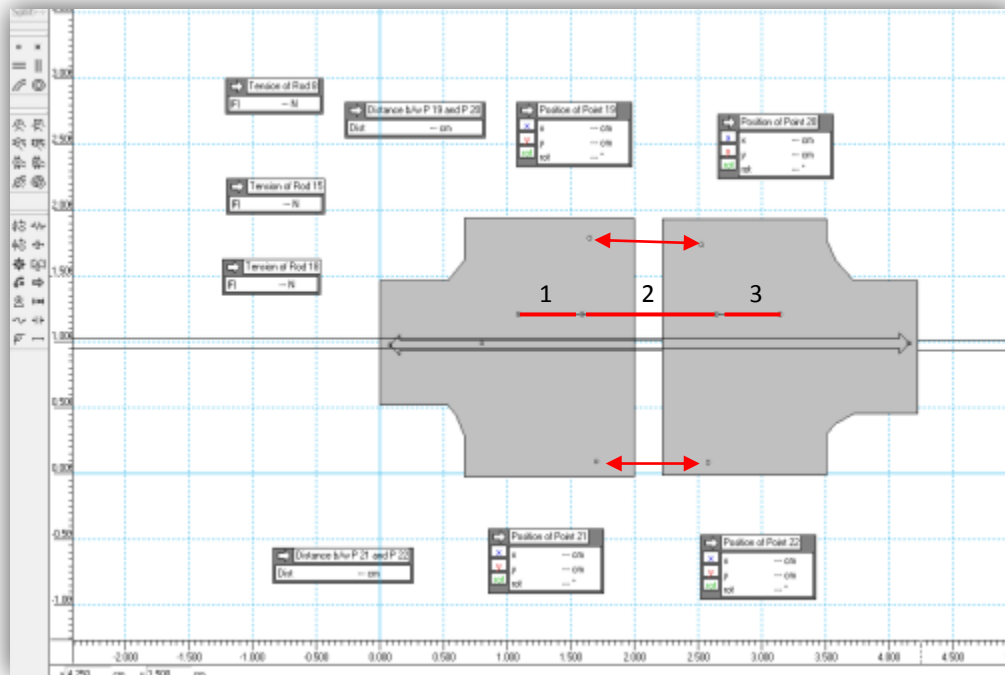

Figure 80: Working Model 2D - Model of an offset plate

The results for the second scenario showed that the tension in the sections 1 and 3 was 0N, whereas in Section 2 was 52.9N. The superior separation of the offset model was 0.34 mm, and the inferior was 0.79 mm (Table 16).

The third model was developed as an angled plate placed across the line of the loading at an angle. In this case the plate was subjected to torque due to the uneven distribution of the forces. The setup is shown in Figure 81 with red arrows denoting the measurements of the bone separation and red lines showing the 3 sections of the plate model. The middle section of the plate is longer than the rest, so the load is distributed across this portion.

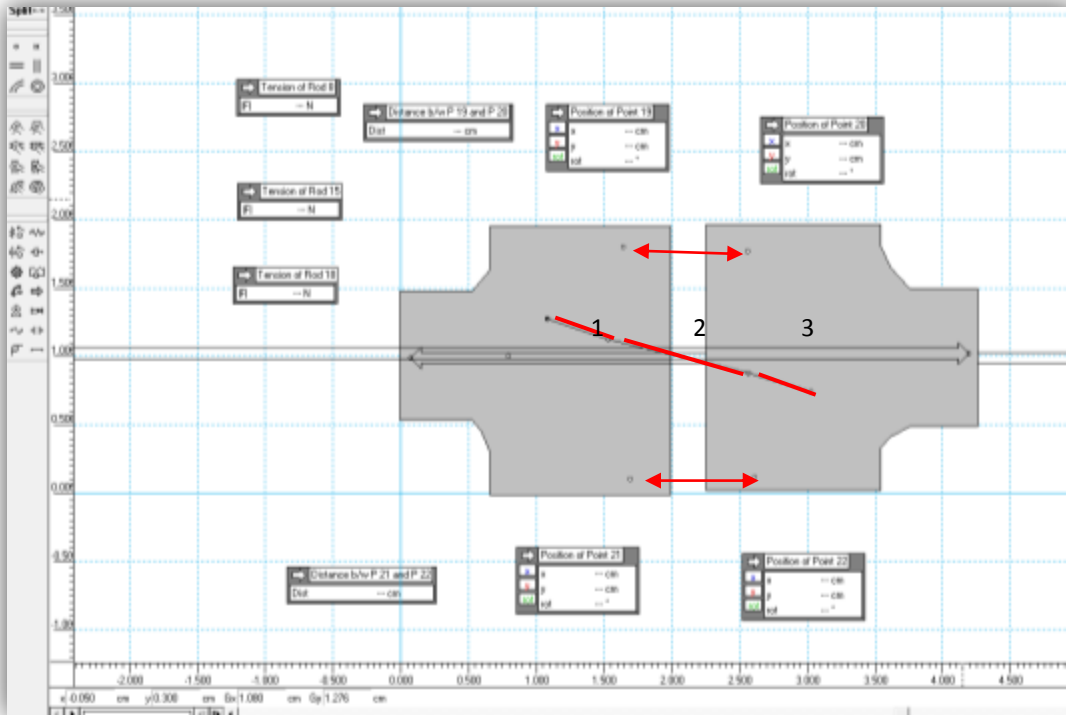
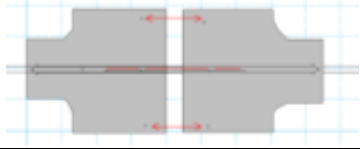



Figure 81: Working Model 2D - Model of an angled plate

The results for the second scenario showed that the tension in the sections 1 and 3 was 0N, whereas in Section 2 was 57.9N (

Table 17). The superior separation of the offset model was 0.39 mm, and the inferior was 0.38 mm (Table 16).

Table 16: Comparison of bone separation data for the Working Model 2D simulation

| Bone separation   | Superior Side<br>Bone separation [mm] | Inferior Side<br>Bone separation [mm] |
|---|---------------------------------------|---------------------------------------|
| Straight<br> | 0.17                                  | 0.25                                  |
| Offset<br>   | 0.34                                  | 0.79                                  |

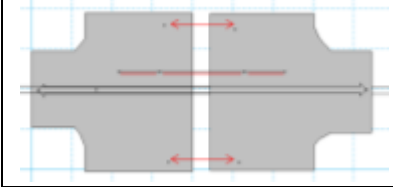
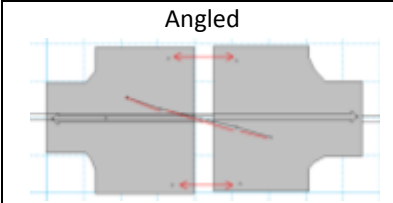

|   |      |      |
|---|------|------|
|                |      |      |
|  <p>Angled</p> | 0.39 | 0.38 |

Given that the actual sample used for modeling (sample B3) had plate that was slightly angled (Figure 32) and the measured separation between the sternal halves was 0.39 mm it can be confirmed that the simulated model was validated through real testing data, because the model gave bone separation of 0.39 mm superior and 0.38 mm inferior separation . Once validated the model was used for further analysis of parameters that were not tested during the in vitro testing of the polyurethane sternal rib pairs. Two factors of interest were the separation between the sternal halves of the modeled sternal rib pair, and tension in the 3 sections of the plate model.

Analyzing the bone separation results it was noticed that the offset and angled plates had larger separation between the sternal halves than the straight plates. There was considerably larger separation on the inferior side of the offset plate compared to the rest of the scenarios. This is a result of the large distance between the fixation plate and the inferior side of the sample.

Analyzing the tension in the middle section of the plate model it was observed that the straight plate has the lowest tension (50.5 N), therefore the screws will be exposed to a load with a magnitude close to the applied force. In contrast, the angled plate had the highest tension measured (57.9 N), which suggests that the plates that have been applied at an angle relative to

the loading will bear significantly larger force compared to the straight or offset plates as shown in Table 17.

Table 17: Comparison of rod tension data for the Working Model 2D simulation

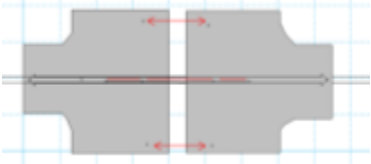
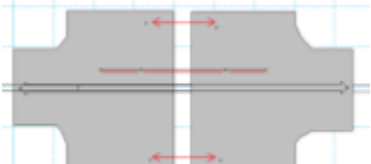
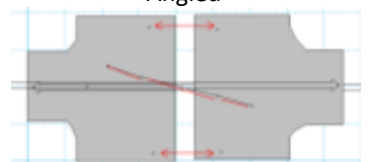
|   | Section 2<br>Tension [N] |
|---|--------------------------|
|  <p style="text-align: center;">Straight</p> | 50.5                     |
|  <p style="text-align: center;">Offset</p>   | 52.9                     |
|  <p style="text-align: center;">Angled</p> | 57.9                     |

The simulated sternal rib pair model was validated using data from the in vitro testing of a polyurethane sample. The model was used to analyze the importance of positioning the plate relative to the median sternotomy and relative to the ribs. It was found that applying the plates perpendicular to the sternotomy cut and in line with the applied forces (centered with respect to the superior and inferior sides of the ribs) would reduce the tension in the plate and the loading on the screws that hold the plate. As a result, the separation between the sternal halves during loading and unloading will be minimal. Since the model has been validated it can be used for further analysis on rib pairs for modeling various scenarios, such as unbalanced forces, different plate shapes and sizes, and various rib pair models.

## CHAPTER 5. PROJECT CONSIDERATIONS

### 5.1 ECONOMIC

This research does not have much of an economic impact on everyday living. In the future if a new sternal closure device results from this study, a slight economic change might be felt by medical device companies. They would manufacture and market the new product which would have some economical impact on their company but not to a higher extent than most other new products they take on and develop. In short, the medical device industry is well equipped to handle new types of products so this device would not change their infrastructure or monetary activities to a high degree.

### 5.2 ENVIRONMENTAL IMPACT

This project does not pose any real environmental concerns. The goal of this research was to compare the effects of various rigid sternal fixation systems in osteoporotic and cadaveric sternal tissue and determine which components best minimize sternal dehiscence, splay, and screw loosening. The only influence environmentally that this research may have would be the manufacturing implications of making the testing devices and the waste created by the potting medium. However, fairly little material is needed to create the testing fixtures and they are reusable. The fixtures are created in a machine shop that is well equipped to manufacture this type of instrument and would require little additional energy. Each test does generate some

waste in the form of two epoxy putty blocks. These are unable to be recycled, but they are relatively small for the amount of information gathered from this research.

---

### 5.3 SOCIETAL INFLUENCES AND POLITICAL RAMIFICATIONS

The development of a new rigid sternal fixation system is intended to increase the success of various open heart procedures which require a median sternotomy. The information gained from this research will allow better guided studies to take place and find the best solution for sternal closure in osteoporotic patients. The end result of this will be fewer incidences of sternal infections, sternal instability, and the need for costly revision surgeries for patients. This research does not have any political ramifications.

---

### 5.4 ETHICAL CONSIDERATIONS

The ethical considerations surrounding our research would come into play when considering which patients are best suited for rigid sternal fixation systems. Many patients have no complications from the use of traditional cerclage wires, however there are patients where these wires could be detrimental to the patient and require them to undergo difficult and risky revision surgeries. How would sternal fixation choice be standardized? How would we ensure that this system is a widespread technology, available nationwide? These questions would need to be answered in order to ethically use rigid fixation systems in the future. Our research in particular does not have any ethical ramifications as our testing is conducted on bone model and cadaveric tissue that is donated by individuals for these types of uses.

---

### 5.5 HEALTH AND SAFETY ISSUES

This research is intended to gather information about rigid sternal fixation systems to ultimately improve sternal stability and to minimize sternal dehiscence and splay post median sternotomy. All laboratory precautions are taken when working with cadaveric tissue to maintain safe conditions for the research team and others using the laboratory space. With this research we hope that improved sternal fixation systems will be developed that will help patients who are not good candidates for sternal closure via cerclage wires.

---

## 5.6 MANUFACTURABILITY

The testing fixtures used to carry this research were easily manufacturable and are able to be made in the future with the same ease. Our device is quite simple from a manufacturing standpoint while still meeting all of our requirements for testing. Standard metal cutting and welding methods are all that are needed to create these testing fixtures. With the CAD drawings of our fixtures along with the extensive protocol for both polyurethane bone model and cadaveric tissue found in the appendix, our testing method and research should be easily reproducible for others.

---

## 5.7 SUSTAINABILITY

This research requires little energy as a whole. Some energy is needed to manufacture the testing fixtures, but this is done in a machine shop that is accustomed to making a large quantity of metallic devices very often. Our devices are reusable so that new fixtures do not have to be made for each test. To complete testing, some energy is used in order to run the computer console and Instron machine. However, this is a very small amount of energy and is not significant.

## CHAPTER 6. FINAL DESIGN AND VERIFICATION

At the outset of this project, the team was tasked with developing a bilateral rigid sternal closure testing system that would be able to measure sternal displacement and screw loosening to characterize the effects of various fixation systems on bisected sterna. To help develop the testing method, client discussions took place in order to define the most important objectives of the testing device. Bilateral cyclic testing, accommodation of initial splay, use of sternum appropriate fixation devices, test reproducibility, instrumentation reproducibility, accommodation of multiple bone models, and reusability of the testing system were defined as the most important factors for our testing device. Multiple test alternatives were developed. After rating how well each one met these criteria, we decided to use the bilateral testing device with guiding rails and screws. This device met all of the most important criteria for the testing method and was the most user friendly. This method consists of two fixtures, one to grip each half of the sternum allowing bilateral testing. These fixtures had t-shaped ends that were used to load into the Instron testing machine. The guiding rail and screw system allowed the sample to be aligned consistently and accurately for each test. This guiding system also allows initial splay to be accommodated for. The sample can be inserted into the guiding system slightly angled so that the sample is not pulled apart further due to being aligned linearly. These fixtures are also reusable as the walls can be removed to remove the sample and potting material after each test. Additionally, a custom Bluehill program was developed to test each sample. This program was

developed to mimic in vivo breathing by loading the sample to 50N each cycle at a rate of 33N/s. Also the test was run for 2500 cycles which mimics approximately two hours of breathing. Lastly, mandibular reconstruction screws and plates were chosen to be tested for use on the sternum. These were chosen for their more sternum appropriate size than other orthopedic systems currently on the market.

Upon attempting to validate the system, several problems were encountered. First, the first potting material, PMMA bone cement, slipped too much from the grips so a new potting material was tried. All-purpose epoxy putty was used next. This putty gripped the sample sufficiently; however it was very difficult to remove after testing. To guard against this, a layer of scotch tape was applied to the inside of the fixture before the potting material was added. Lastly, c-clamps were added to hold the fixture and potting material together during testing to prevent slippage.

Overall, this testing system met all needs of this research and was easy to use and understand. This device is also able to accommodate both polyurethane bone models and cadaveric tissue which is essential for continuation of testing in this area. We would recommend that this device be utilized in the continuation of these studies for all of its benefits as discussed earlier.

## CHAPTER 7. CONCLUSION AND FUTURE RECOMMENDATIONS

In conclusion, an effective bilateral cyclic testing device was designed and developed that can be used to mimic *in vivo* breathing forces in order to test fixation systems applied on both polyurethane bone model and cadaveric tissue. Additionally, several conclusions can be drawn as a result of the testing conducted using this testing device. While two types of failures limited the sample sizes and statistical significance of the final data, pre-testing measurement analysis created a constructive outcome as a result of setup failures. It was found that horizontal plate centering is an important aspect of hardware application, and that, if controlled properly, it can greatly reduce the number of setup failures. Another conclusion that can be drawn from the testing that was performed, is that unicortical configurations perform as well as, if not better, than bicortical configurations. These configurations were not statistically different in polyurethane testing, while they were statistically different in cadaveric tissue favoring unicortical configurations. This is beneficial because until now bicortical configuration has been the gold standard in clinical practice; however, they pose a threat of piercing through the posterior side of the sternum, damaging vital organs. Unicortical configurations can prevent this danger from occurring altogether. Additionally, testing results showed a trend that 2.3mm diameter screws minimized bone separation and screw loosening more than 2.0mm and 2.7mm diameter screws. While these results were not statistically significant, this trend is in agreement with the fact that 2.3mm diameter screws are the current gold standard in clinical practice. Lastly, testing results demonstrated that standard and locking systems comparably minimized



bone separation and screw loosening. These systems were not found to be statistically different, which is consistent with previous research. The similar performance of these two systems is important because, while standard systems are more commonly used in clinical practice, locking systems promote healing as a result of limited bone-plate contact. If the two systems are in fact comparable in mechanical performance, then it is possible that after more research locking systems can replace standard systems to add the benefit of improved healing.

While there were several outcomes from this project that can be used to further research in the field of rigid sternal fixation systems, there were also some limitations that can be improved upon. Firstly, the initial method to measure anterior dehiscence and posterior splay using dot markers and the ImageJ program was unsuccessful because of hysteresis that occurred at the beginning of each test as a result of fixation systems settling into the bone. No picture was taken after the hysteresis occurred, so there was no initial photograph to refer to during analysis. The bone separation results used for analysis were taken from the extension data given by the Instron machine; however this method was unable to allow for separate analyses of dehiscence and splay. Separate analysis of these two measurements is important to ensure that bone separation is minimized to less than 2mm on both side of the sternum. Another limitation of this research was that while the final testing specifications used were more realistic to actual *in vivo* breathing, the number of cycles performed only allowed for performance analysis and not fatigue analysis as originally intended. Performance data is useful to understand general capabilities of fixation systems, but fatigue testing is necessary to ensure performance over an extended length of time.

Following the outcome of this research we have several recommendations for future research and testing. As discussed earlier, both unicortical and bicortical configurations

performed quite similarly. With a p-value of 0.98 we can say that these configurations are not statistically different and seem to perform equally. Therefore, we suggest continuing testing using unicortical configurations only. The reasoning for this is that unicortical configurations allow faster and safer application in surgery, and is safer for the patients. When using bicortical configuration, surgeons must ensure that the screws do not pierce through the posterior of the bone which can cause agitation to other tissues, and specialty screws with rounded tips and a custom length to each patient must be used to accommodate different sternum widths. Unicortical configuration allows more standard length screws to be used and do not require a rounded tip. Additionally, surgeons can be confident that this screw will not pierce through the posterior of the sternum allowing a faster applications time. Another benefit to using unicortical configuration is that there is less risk of compromising the bone's structural integrity. Sometimes when the second cortical layer of bone is pierced by a screw it can either push out the second cortical layer causing a convex shape to occur. Or the inverse can happen where the second cortical layer is pulled in causing it to be concave in shape. These occurrences either stretch or compress the middle cancellous bone layer which can change how the sternum will act mechanically.

Continued research to characterize the effects of standard and locking fixation systems is also recommended for the future. A data trend showed that both standard and locking systems reduced bone separation and screw loosening to a higher extent than compression systems. Therefore continuing studies in this area will allow for more data to be gathered about the systems and find which performs best. Lastly, we advise that future testing be carried out using cadaveric tissue instead of polyurethane sawbones. Cadaveric tissue is able to more closely mimic clinical conditions than other bone models and will result in more accurate data. The

polyurethane models used do not have proper cortical and cancellous layers, so using cadaveric tissue will allow this distinction. Though, when using cadaveric tissue the mechanical structure of the bone is variable. Therefore, bone density analysis should be conducted on all samples before testing so they can be categorized based on their degree of osteoporosis.

## REFERENCES

- "Cardiovascular Disease Statistics." 2006. *American Heart Association*. 10 Oct. 2009  
<<http://www.americanheart.org/presenter.jhtml?identifier=4478>>.
- "Heart Disease and Stroke Statistics — 2009 Update." 2009. *American Heart Association*. 10 Oct. 2009.  
<<http://www.americanheart.org/presenter.jhtml?identifier=3037327>>.
- "Heart and stroke death rates down, some risk factors still too high." 2008. *American Heart Association*.  
10 Oct. 2009 <<http://americanheart.mediaroom.com/index.php?s=43&item=626>>.
- "Older Americans and Cardiovascular Diseases." 2009. *American Heart Association*. 10 Oct. 2009  
<<http://www.americanheart.org/presenter.jhtml?identifier=3000936>>.
- "Open-Heart Surgery Statistics." 2009. *American Heart Association*. 2006. 15 Oct. 2009.  
<<http://www.americanheart.org/presenter.jhtml?identifier=4674>>.
- "Men and Osteoporosis." 2009. *National Osteoporosis Foundation*. 15 Oct. 2009.  
<<http://www.nof.org/men>>.
- "NOF Advocacy - The State of Osteoporosis and Low Bone Mass in the US." 2009. *National Osteoporosis Foundation*. 15 Oct. 2009. <<http://www.nof.org/advocacy/prevalence>>.
- Ahmad, M. "Biomechanical testing of the locking compression plate: When does the distance between bone and implant significantly reduce construct stability?" *International Journal of the care of the injured* 38 (2007): 358-64.
- Ahn et al. Design of an Optimized Rigid Fixation System for the Osteoporotic Sternum. Worcester Polytechnic Institute. (2009) Worcester, MA.
- Bagby, GW. "Compression bone-plating: historical considerations." *Journal of Bone and Joint Surgery*. 59(1977):625-631.
- Brown, GA. "Mechanical Performance of Standard and Cannulated 4.0 mm Cancellous Bone Screws." *Journal of Orthopaedic Research* (2000) 18: 307-312.
- Bruhlin, Raimund. "Numerical simulation Techniques to Study the Structural Response of the Human Chest Following Median Sternotomy." *The Annals of Thoracic Surgery* (2005) 80: 623-630.
- Chapman et al. 1996. "Factors affecting the Pullout Strength of Cancellous Bone Screws." *ASME Biomech Eng* (1996) 118: 391-398
- Cohen, D. & Griffin, L. "A biomechanical comparison of three sternotomy closure techniques." *The Annals of Thoracic Surgery* (2002) 73: 563-568.
- Crown Metal Works. (2009). Retrieved Oct 2 2009 from  
[http://www.crownmetalworks.com/orthopedic\\_implants.html](http://www.crownmetalworks.com/orthopedic_implants.html)

- Decoteau, D., et al. "Comparison of Cancellous and Cortical Bone Screws for Sternal Application." Worcester Polytechnic Institute. (2006) Worcester, MA.
- Egol, Kenneth A. "Biomechanics of Locked Plates and Screws." *Journal of Orthopedic Trauma* (2004) 18.8: 488-93.
- Eijer, H. "PC-Fix and local infection resistance - Influence of implant design on postoperative infection development, clinical and experimental results" *International Journal of the Care of the Injured* (2001) 32: 38-43.
- Field, John R. "The influence of screw torque, object radius of curvature, mode of bone plate application and bone plate design on bone-plate interface mechanics." *Injury* (1998) 29.3: 233-41.
- Gardner, Michael J. "Hybrid Locked Plating of Osteoporotic Fractures of the Humerus." *The Journal of Bone and Joint Surgery* (2006) 88-A.9: 1962-966.
- Greiwe, Michael R. "Locking Plate Technology: Current Concepts." *The Journal of Knee Surgery* (2007) 20.1: 50-55.
- Grey, Henry. "II. Osteology. 4a. Sternum." *Anatomy of the Human Body: 20th ed.* Philadelphia: Lea & Febiger, 1918.
- Kun, Hua. "Median sternotomy closure: review and update research." *Journal of Medical Colleges of PLA* (2009) 24: 112-17.
- Lepelletier, D. et al. "Risk factors for mortality in patients with mediastinitis after cardiac surgery" *Archives of Cardiovascular Disease* (2009) 102: 119-125.
- Losanoff, J., et al. "Biomechanical Comparison of Median Sternotomy Closures." *The Annals of Thoracic Surgery* (2004) 77: 203-209.
- Malizos, Konstantinos N. "The Healing Potential of the periosteum molecular aspects." *International Journal of the Care of the Injured* (2005) 36S: S13-19.
- Martinez, Honguero. "Descending Necrotizing Mediastinitis: Treatment by Transcervical Thoracic Drainage." *Arch Bronconeumol* (2005) 41.5: 293-94.
- McGregor, W., Trumble, D., & Magovern, J. "Mechanical Analysis of Midline Sternotomy Wound Closure." *The Journal of Thoracic and Cardiovascular Surgery* (1999) 117: 1144-1149.
- Medscape. (2009). Retrieved Sept 12, 2009, from MedScape:  
[http://img.medscape.com/pi/emed/ckb/orthopedic\\_surgery/1230552-1269987-2333.jpg](http://img.medscape.com/pi/emed/ckb/orthopedic_surgery/1230552-1269987-2333.jpg)
- Ozaki, Wayne. "Biomechanical Study of Sternal Closure Using Rigid Fixation Techniques in Human Cadavers." *The Annals of Thoracic Surgery* (1998) 65: 1660-665.
- Pai, Shruti., et al. "Characterization of Forces on the Sternal Midline Following Median Sternotomy in a Porcine Model." *The Journal of Biomechanical Engineering* (2008) 130.

- Pai, Shruti., et al. "In Vitro Comparison of Wire and Plate Fixation for Midline Sternotomies." *The Society of Thoracic Surgeons* (2005) 80: 962-8.
- Raman, Jaishankar. "Rigid Plate Fixation of the Sternum." *The Annals of Thoracic Surgery* (2007) 84.3: 1056-058.
- Ratnovsky, A. Anatomical Model of the Human Trunk for analysis of the Respiratory Muscle Mechanics. *Respiratory Physiology & Neurobiology* (2005) 148 (3): 245-62.
- Ratnovsky, A. "Mechanics of respiratory muscles." *Respiratory Physiology & Neurobiology* (2008) 163: 82-89.
- Schutz, Michael. "Revolution in plate osteosynthesis: new internal fixator systems." *Journal of Orthopaedic Science* (2003) 8: 252-58.
- Selthofer, Robert. "Morphometric Analysis of the Sternum." *Collegium Antropologicum* (2006) 30.1: 43-47.
- Shields, LoCicero, Ponn, & Rusch. 2004. *General Thoracic Surgery: Sixth Edition*. Lippincott Williams & Wilkins.
- Song, David H. "Primary sternal plating in high-risk patients prevents mediastinitis." *European Journal of Cardio-thoracic Surgery* 26 (2004): 367-72.
- Voss, Bernhard. "Sternal reconstruction with titanium plates in complicated sternal dehiscence." *European Journal of Cardio-thoracic Surgery* (2008) 34: 139-45.
- Zehnder, Scott. "The effects of screw orientation in severely osteoporotic bone: A comparison with locked plating." *Clinical Biomechanics* (2009) 24: 589-94.

**APPENDIX A- DR. RAYMOND DUNN'S PAIRWISE COMPARISON CHARTS FOR THE BILATERAL TESTING METHOD**

**Pairwise Comparison Chart for Major Design Objectives for Bilateral Testing Device**

|                                     | Ability to Grip Both Sterna Halves | Accuracy | Perform Cyclic Testing | Test Reproducibility | Instrumentation Reproducibility | Cost Effective | Ease of Use | Accommodate Multiple Tissue Samples | Time Efficient | TOTAL Score |
|-------------------------------------|------------------------------------|----------|------------------------|----------------------|---------------------------------|----------------|-------------|-------------------------------------|----------------|-------------|
| Ability to Grip Both Sterna Halves  | X                                  | .5       | .5                     | .5                   | .5                              | 1              | 1           | 0                                   | 0              | 4           |
| Accuracy                            | .5                                 | X        | .5                     | .5                   | .5                              | 1              | 1           | 1                                   | 1              | 6           |
| Perform Cyclic Testing              | .5                                 | .5       | X                      | .5                   | .5                              | 1              | 1           | .5                                  | 1              | 6           |
| Test Reproducibility                | .5                                 | .5       | .5                     | X                    | .5                              | 1              | 1           | .5                                  | 1              | 5.5         |
| Instrumentation Reproducibility     | .5                                 | .5       | .5                     | .5                   | X                               | 1              | 1           | .5                                  | 1              | 5.5         |
| Cost Effective                      | 0                                  | 0        | 0                      | 0                    | 0                               | X              | 0           | 0                                   | 0              | 0           |
| Ease of Use                         | 0                                  | 0        | 0                      | 0                    | 0                               | 0              | X           | 0                                   | 0              | 0           |
| Accommodate Multiple Tissue Samples | 1                                  | 0        | .5                     | .5                   | .5                              | 1              | 1           | X                                   | 1              | 5.5         |
| Time Efficient                      | 1                                  | 0        | 0                      | 0                    | 0                               | 0              | 0           | 0                                   | X              | 1           |

**Pairwise Comparison Charts for Sub-Objectives for Bilateral Testing Device**

Test Reproducibility

|                    | Measure Stability | Measure Dehiscence | TOTAL Score |
|--------------------|-------------------|--------------------|-------------|
| Measure Stability  | X                 | .5                 | .5          |
| Measure Dehiscence | .5                | X                  | .5          |

Instrumentation Reproducibility

|   | Control Force Distribution | Straight Sternotomy Line | Consistent Alignment of Sterna in Grips | Doesn't Alter Mechanical Properties of Tissue | Biocompatible Materials | TOTAL Score |
|---|----------------------------|--------------------------|---|---|-------------------------|-------------|
| Control Force Distribution                    | X                          | .5                       | .5                                      | .5  | 1                       | 2.5         |
| Straight Sternotomy Line                      | .5                         | X                        | .5                                      | .5  | 1                       | 2.5         |
| Consistent Alignment of Sterna in Grips       | .5                         | .5                       | X                                       | .5  | 1                       | 2.5         |
| Doesn't Alter Mechanical Properties of Tissue | .5                         | .5                       | .5                                      | X   | 1                       | 2.5         |
| Biocompatible Materials                       | 0                          | 0                        | 0                                       | 0   | X                       | 0           |



Ease of Use

|                               | Few Components | Computerized Data Acquisition | TOTAL Score |
|-------------------------------|----------------|-------------------------------|-------------|
| Few Components                | X              | 0                             | 0           |
| Computerized Data Acquisition | 1              | X                             | 1           |

Accommodate Multiple Tissue Samples

|                    | Multiple Rib Pairs | Multiple Types | TOTAL Score |
|--------------------|--------------------|----------------|-------------|
| Multiple Rib Pairs | X                  | .5             | .5          |
| Multiple Types     | .5                 | X              | .5          |

Time Efficient

|             | Quick Prep | Quick Reset | TOTAL Score |
|-------------|------------|-------------|-------------|
| Quick Prep  | X          | .5          | .5          |
| Quick Reset | .5         | X           | .5          |

**Pairwise Comparison Charts for Sub-Sub-Objectives for Bilateral Testing Device**

Measure Dehiscence

|                     | Anterior Dehiscence | Posterior Splay | TOTAL Score |
|---------------------|---------------------|-----------------|-------------|
| Anterior Dehiscence | X                   | .5              | .5          |
| Posterior Splay     | .5                  | X               | .5          |

Accommodate Multiple Rib Pairs

|         | Size | Shape | Density | TOTAL Score |
|---------|------|-------|---------|-------------|
| Size    | X    | .5    | .5      | 1           |
| Shape   | .5   | X     | .5      | 1           |
| Density | .5   | .5    | X       | 1           |

Accommodate Multiple Types of Tissue Samples

|               | Polyurethane | Fresh Cadaver | Fixed Cadaver | TOTAL Score |
|---------------|--------------|---------------|---------------|-------------|
| Polyurethane  | X            | 0             | 0             | 0           |
| Fresh Cadaver | 1            | X             | 1             | 2           |
| Fixed Cadaver | 1            | 0             | X             | 1           |

**APPENDIX B- DR. JANICE LALIKOS' PAIRWISE COMPARISON CHARTS FOR THE BILATERAL TESTING METHOD**

**Pairwise Comparison Chart for Major Design Objectives for Bilateral Testing Device**

|                                     | Ability to Grip Both Sterna Halves | Accuracy | Perform Cyclic Testing | Test Reproducibility | Instrumentation Reproducibility | Cost Effective | Ease of Use | Accommodate Multiple Tissue | Time Efficient | TOTAL Score |
|-------------------------------------|------------------------------------|----------|------------------------|----------------------|---------------------------------|----------------|-------------|-----------------------------|----------------|-------------|
| Ability to Grip Both Sterna Halves  | X                                  | 1        | 1                      | 1                    | 0.5                             | 1              | 1           | 1                           | 1              | 7.5         |
| Accuracy                            | 0                                  | X        | 0.5                    | 0.5                  | 0.5                             | 1              | 1           | 1                           | 1              | 5.5         |
| Perform Cyclic Testing              | 0                                  | 0.5      | X                      | 0.5                  | 0.5                             | 1              | 1           | 1                           | 1              | 5.5         |
| Test Reproducibility                | 0                                  | 0.5      | 0.5                    | X                    | 0.5                             | 1              | 1           | 1                           | 1              | 5.5         |
| Instrumentation Reproducibility     | 0.5                                | 0.5      | 0.5                    | 0.5                  | X                               | 1              | 1           | 1                           | 1              | 6           |
| Cost Effective                      | 0                                  | 0        | 0                      | 0                    | 0                               | X              | 1           | 0                           | 0.5            | 1.5         |
| Ease of Use                         | 0                                  | 0        | 0                      | 0                    | 0                               | 0              | X           | 0                           | 0.5            | 0.5         |
| Accommodate Multiple Tissue Samples | 0                                  | 0        | 0                      | 0                    | 0                               | 1              | 1           | X                           | 0.5            | 2.5         |
| Time Efficient                      | 0                                  | 0        | 0                      | 0                    | 0                               | 0.5            | 0.5         | 0.5                         | X              | 1.5         |

**Pairwise Comparison Charts for Sub-Objectives for Bilateral Testing Device**

Test Reproducibility

|                    | Measure Stability | Measure Dehiscence | TOTAL Score |
|--------------------|-------------------|--------------------|-------------|
| Measure Stability  | X                 | 0.5                | 0.5         |
| Measure Dehiscence | 0.5               | X                  | 0.5         |

Instrumentation Reproducibility

|   | Control Force Distribution | Straight Sternotomy Line | Consistent Alignment of Sterna in Grips | Doesn't Alter Mechanical Properties of Tissue | Biocompatible Materials | TOTAL Score |
|---|----------------------------|--------------------------|---|---|-------------------------|-------------|
| Control Force Distribution                    | X                          | 1                        | 0.5                                     | 0.5   | 0.5                     | 2.5         |
| Straight Sternotomy Line                      | 0                          | X                        | 0                                       | 0   | 0                       | 0           |
| Consistent Alignment of Sterna in Grips       | 0.5                        | 1                        | X                                       | 0.5   | 0.5                     | 2.5         |
| Doesn't Alter Mechanical Properties of Tissue | 0.5                        | 1                        | 0.5                                     | X   | 0.5                     | 2.5         |
| Biocompatible Materials                       | 0.5                        | 1                        | 0.5                                     | 0.5   | X                       | 2.5         |

Ease of Use

|                               | Few Components | Computerized Data Acquisition | TOTAL Score |
|-------------------------------|----------------|-------------------------------|-------------|
| Few Components                | X              | 0                             | 0           |
| Computerized Data Acquisition | 1              | X                             | 1           |

Accommodate Multiple Tissue Samples

|                    | Multiple Rib Pairs | Multiple Types | TOTAL Score |
|--------------------|--------------------|----------------|-------------|
| Multiple Rib Pairs | X                  | 1              | 1           |
| Multiple Types     | 0                  | X              | 0           |

Time Efficient

|             | Quick Prep | Quick Reset | TOTAL Score |
|-------------|------------|-------------|-------------|
| Quick Prep  | X          | 0           | 0           |
| Quick Reset | 1          | X           | 1           |

**Pairwise Comparison Charts for Sub-Sub-Objectives for Bilateral Testing Device**

Measure Dehiscence

|                     | Anterior Dehiscence | Posterior Splay | TOTAL Score |
|---------------------|---------------------|-----------------|-------------|
| Anterior Dehiscence | X                   | 0.5             | 0.5         |
| Posterior Splay     | 0.5                 | X               | 0.5         |

Accommodate Multiple Rib Pairs

|         | Size | Shape | Density | TOTAL Score |
|---------|------|-------|---------|-------------|
| Size    | X    | 0     | 0       | 0           |
| Shape   | 1    | X     | 1       | 2           |
| Density | 1    | 1     | X       | 2           |

Accommodate Multiple Types of Tissue Samples

|               | Polyurethane | Fresh Cadaver | Fixed Cadaver | TOTAL Score |
|---------------|--------------|---------------|---------------|-------------|
| Polyurethane  | X            | 1             | 1             | 2           |
| Fresh Cadaver | 0            | X             | 1             | 1           |
| Fixed Cadaver | 0            | 0             | X             | 0           |



**APPENDIX C- DR. RONALD IGNOTZ'S PAIRWISE COMPARISON CHARTS FOR THE BILATERAL TESTING METHOD**

**Pairwise Comparison Chart for Major Design Objectives for Bilateral Testing Device**

|                                       | 1 Ability to Grip Both Sterna Halves | 2 Accuracy | 3 Perform Cyclic Testing | 4 Test Reproducibility | 5 Instrumentation Reproducibility | 6 Cost Effective | 7 Ease of Use | 8 Accommodate Multiple Tissue | 9 Time Efficient | TOTAL Score |
|---------------------------------------|--------------------------------------|------------|--------------------------|------------------------|-----------------------------------|------------------|---------------|-------------------------------|------------------|-------------|
| 1 Ability to Grip Both Sterna Halves  | X                                    | 0          | 0.5                      | 0                      | 0                                 | 1                | 1             | 1                             | 1                | 4.5         |
| 2 Accuracy                            | 1                                    | X          | 0.5                      | 0.5                    | 0.5                               | 1                | 1             | 1                             | 1                | 6.5         |
| 3 Perform Cyclic Testing              | 0.5                                  | 0.5        | X                        | 0.5                    | 0.5                               | 1                | 1             | 1                             | 1                | 6           |
| 4 Test Reproducibility                | 1                                    | 0.5        | 0.5                      | X                      | 1                                 | 1                | 1             | 1                             | 1                | 7           |
| 5 Instrumentation Reproducibility     | 1                                    | 0.5        | 0.5                      | 0                      | X                                 | 1                | 1             | 1                             | 1                | 6           |
| 6 Cost Effective                      | 0                                    | 0          | 0                        | 0                      | 0                                 | X                | 0             | 1                             | 1                | 2           |
| 7 Ease of Use                         | 0                                    | 0          | 0                        | 0                      | 0                                 | 1                | X             | 1                             | 1                | 3           |
| 8 Accommodate Multiple Tissue Samples | 0                                    | 0          | 0                        | 0                      | 0                                 | 0                | 0             | X                             | 0                | 0           |
| 9 Time Efficient                      | 0                                    | 0          | 0                        | 0                      | 0                                 | 0                | 0             | 1                             | X                | 1           |

**Pairwise Comparison Charts for Sub-Objectives for Bilateral Testing Device**

Test Reproducibility

|                      | 2 Measure Stability | 2 Measure Dehiscence | TOTAL Score |
|----------------------|---------------------|----------------------|-------------|
| 1 Measure Stability  | <b>X</b>            | <b>1</b>             | <b>1</b>    |
| 2 Measure Dehiscence | <b>0</b>            | <b>X</b>             | <b>0</b>    |

Instrumentation Reproducibility

|   | 1 Control Force Distribution | 2 Straight Sternotomy Line | 3 Consistent Alignment of Sterna in Grips | 4 Doesn't Alter Mechanical Properties of Tissue | 5 Biocompatible Materials | TOTAL Score |
|---|------------------------------|----------------------------|---|---|---------------------------|-------------|
| 1 Control Force Distribution                    | <b>X</b>                     | <b>1</b>                   | <b>0.5</b>                                | <b>1</b>  | <b>1</b>                  | <b>3.5</b>  |
| 2 Straight Sternotomy Line                      | <b>0</b>                     | <b>X</b>                   | <b>1</b>                                  | <b>1</b>  | <b>1</b>                  | <b>3</b>    |
| 3 Consistent Alignment of Sterna in Grips       | <b>0.5</b>                   | <b>0</b>                   | <b>X</b>                                  | <b>1</b>  | <b>1</b>                  | <b>2.5</b>  |
| 4 Doesn't Alter Mechanical Properties of Tissue | <b>0</b>                     | <b>0</b>                   | <b>0</b>                                  | <b>X</b>  | <b>1</b>                  | <b>1</b>    |
| 5 Biocompatible Materials                       | <b>0</b>                     | <b>0</b>                   | <b>0</b>                                  | <b>0</b>  | <b>X</b>                  | <b>0</b>    |

Ease of Use

|                                 | 2 Few Components | 2 Computerized Data Acquisition | TOTAL Score |
|---------------------------------|------------------|---------------------------------|-------------|
| 1 Few Components                | X                | 1                               | 1           |
| 2 Computerized Data Acquisition | 0                | X                               | 0           |

Accommodate Multiple Tissue Samples

|                      | 1 Multiple Rib Pairs | 2 Multiple Types | TOTAL Score |
|----------------------|----------------------|------------------|-------------|
| 1 Multiple Rib Pairs | X                    | 0                | 0           |
| 2 Multiple Types     | 1                    | X                | 1           |

Time Efficient

|               | 1 Quick Prep | 2 Quick Reset | TOTAL Score |
|---------------|--------------|---------------|-------------|
| 1 Quick Prep  | X            | 1             | 1           |
| 2 Quick Reset | 0            | X             | 0           |

**Pairwise Comparison Charts for Sub-Sub-Objectives for Bilateral Testing Device**

Measure Dehiscence

|                       | 1 Anterior Dehiscence | 2 Posterior Splay | TOTAL Score |
|-----------------------|-----------------------|-------------------|-------------|
| 1 Anterior Dehiscence | X                     | 1                 | 1           |
| 2 Posterior Splay     | 0                     | X                 | 0           |

Accommodate Multiple Rib Pairs

|           | 1 Size | 2 Shape | 3 Density | TOTAL Score |
|-----------|--------|---------|-----------|-------------|
| 1 Size    | X      | 0       | 0         | 0           |
| 2 Shape   | 1      | X       | 0         | 1           |
| 3 Density | 1      | 1       | X         | 2           |

Accommodate Multiple Types of Tissue Samples

|                 | 1 Polyurethane | 2 Fresh Cadaver | 3 Fixed Cadaver | TOTAL Score |
|-----------------|----------------|-----------------|-----------------|-------------|
| 1 Polyurethane  | X              | 0               | 0               | 0           |
| 2 Fresh Cadaver | 1              | X               | 1               | 2           |
| 3 Fixed Cadaver | 1              | 0               | X               | 1           |

**APPENDIX D- PROFESSOR GEORGE PINS' PAIRWISE COMPARISON CHARTS FOR THE BILATERAL TESTING METHOD**

**Pairwise Comparison Chart for Major Design Objectives for Bilateral Testing Device**

|                                     | Ability to Grip Both Sterna Halves | Accuracy | Perform Cyclic Testing | Test Reproducibility | Instrumentation Reproducibility | Cost Effective | Ease of Use | Accommodate Multiple Tissue Samples | Time Efficient | TOTAL Score |
|-------------------------------------|------------------------------------|----------|------------------------|----------------------|---------------------------------|----------------|-------------|-------------------------------------|----------------|-------------|
| Ability to Grip Both Sterna Halves  | X                                  | 1        | 0.5                    | 0.5                  | 0.5                             | 1              | 1           | 1                                   | 1              | 6.5         |
| Accuracy                            | 0                                  | X        | 0                      | 0                    | 0                               | 0              | 0           | 0                                   | 0              | 0           |
| Perform Cyclic Testing              | 0.5                                | 1        | X                      | 0.5                  | 0.5                             | 1              | 1           | 1                                   | 1              | 6.5         |
| Test Reproducibility                | 0.5                                | 1        | 0.5                    | X                    | 0.5                             | 1              | 1           | 1                                   | 1              | 6.5         |
| Instrumentation Reproducibility     | 0.5                                | 1        | 0.5                    | 0.5                  | X                               | 1              | 1           | 1                                   | 1              | 6.5         |
| Cost Effective                      | 0                                  | 1        | 0                      | 0                    | 0                               | X              | 1           | 0                                   | 1              | 3           |
| Ease of Use                         | 0                                  | 1        | 0                      | 0                    | 0                               | 0              | X           | 0                                   | 0.5            | 1.5         |
| Accommodate Multiple Tissue Samples | 0                                  | 1        | 0                      | 0                    | 0                               | 1              | 1           | X                                   | 1              | 4           |
| Time Efficient                      | 0                                  | 1        | 0                      | 0                    | 0                               | 0              | 0.5         | 0                                   | X              | 1.5         |

**Pairwise Comparison Charts for Sub-Objectives for Bilateral Testing Device**

Test Reproducibility

|                    | Measure Stability | Measure Dehiscence | TOTAL Score |
|--------------------|-------------------|--------------------|-------------|
| Measure Stability  | X                 | 0.5                | 0.5         |
| Measure Dehiscence | 0.5               | X                  | 0.5         |

Instrumentation Reproducibility

|   | Control Force Distribution | Straight Sternotomy Line | Consistent Alignment of Sterna in Grips | Doesn't Alter Mechanical Properties of Tissue | Biocompatible Materials | TOTAL Score |
|---|----------------------------|--------------------------|---|---|-------------------------|-------------|
| Control Force Distribution                    | X                          | 0.5                      | 0.5                                     | 0.5   | ?                       | 1.5         |
| Straight Sternotomy Line                      |                            | X                        | 0.5                                     | 0.5   | ?                       | 1.5         |
| Consistent Alignment of Sterna in Grips       |                            |                          | X                                       | 0.5   | ?                       | 1.5         |
| Doesn't Alter Mechanical Properties of Tissue |                            |                          |   | X   | ?                       | 1.5         |
| Biocompatible Materials                       |                            |                          |   |   | X                       | ???         |

Ease of Use

|                               | Few Components | Computerized Data Acquisition | TOTAL Score |
|-------------------------------|----------------|-------------------------------|-------------|
| Few Components                | X              | 0                             | 0           |
| Computerized Data Acquisition | 1              | X                             | 1           |

Accommodate Multiple Tissue Samples

|                    | Multiple Rib Pairs | Multiple Types | TOTAL Score |
|--------------------|--------------------|----------------|-------------|
| Multiple Rib Pairs | X                  | 1              | 1           |
| Multiple Types     | 0                  | X              | 0           |

Time Efficient

|             | Quick Prep | Quick Reset | TOTAL Score |
|-------------|------------|-------------|-------------|
| Quick Prep  | X          | 0.5         | 0.5         |
| Quick Reset | 0.5        | X           | 0.5         |



**Pairwise Comparison Charts for Sub-Sub-Objectives for Bilateral Testing Device**

Measure Dehiscence

|                     | Anterior Dehiscence | Posterior Splay | TOTAL Score |
|---------------------|---------------------|-----------------|-------------|
| Anterior Dehiscence | X                   | 0.5             | 0.5         |
| Posterior Splay     | 0.5                 | X               | 0.5         |

Accommodate Multiple Rib Pairs

|         | Size | Shape | Density | TOTAL Score |
|---------|------|-------|---------|-------------|
| Size    | X    | 0.5   | 1       | 1.5         |
| Shape   | 0.5  | X     | 1       | 1.5         |
| Density | 0    | 0     | X       | 0           |

Accommodate Multiple Types of Tissue Samples

|               | Polyurethane | Fresh Cadaver | Fixed Cadaver | TOTAL Score |
|---------------|--------------|---------------|---------------|-------------|
| Polyurethane  | X            | 1             | 1             | 2           |
| Fresh Cadaver | 0            | X             | 1             | 1           |
| Fixed Cadaver | 0            | 0             | X             | 0           |

**APPENDIX E- PROFESSOR KRYSZYNA GIELO-PERCZAK'S PAIRWISE COMPARISON CHARTS FOR THE BILATERAL TESTING METHOD**

**Pairwise Comparison Chart for Major Design Objectives for Bilateral Testing Device**

|                                     | Ability to Grip Both Sterna Halves | Accuracy | Perform Cyclic Testing | Test Reproducibility | Instrumentation Reproducibility | Cost Effective | Ease of Use | Accommodate Multiple Tissue Samples | Time Efficient | TOTAL Score |
|-------------------------------------|------------------------------------|----------|------------------------|----------------------|---------------------------------|----------------|-------------|-------------------------------------|----------------|-------------|
| Ability to Grip Both Sterna Halves  | X                                  | 1        | 0.5                    | 0.5                  | 0.5                             | 1              | 1           | 1                                   | 1              | 6.5         |
| Accuracy                            | 0                                  | X        | 0                      | 0                    | 0                               | 0              | 0           | 0                                   | 0              | 0           |
| Perform Cyclic Testing              | 0.5                                | 1        | X                      | 1                    | 1                               | 1              | 1           | 1                                   | 1              | 7.5         |
| Test Reproducibility                | 0.5                                | 1        | 0.5                    | X                    | 0.5                             | 1              | 1           | 1                                   | 1              | 6.5         |
| Instrumentation Reproducibility     | 0.5                                | 1        | 1                      | 1                    | X                               | 1              | 1           | 1                                   | 1              | 7.5         |
| Cost Effective                      | 0                                  | 1        | 0.5                    | 0                    | 0                               | X              | 1           | 1                                   | 1              | 4.5         |
| Ease of Use                         | 0                                  | 1        | 0.5                    | 0.5                  | 0.5                             | 0              | X           | 1                                   | 1              | 4.5         |
| Accommodate Multiple Tissue Samples | 0                                  | 1        | 0                      | 0                    | 0                               | 1              | 1           | X                                   | 1              | 4.0         |
| Time Efficient                      | 0                                  | 1        | 0                      | 0                    | 0                               | 0              | 0.5         | 0.5                                 | X              | 1.5         |

**Pairwise Comparison Charts for Sub-Objectives for Bilateral Testing Device**

Test Reproducibility

|                    | Measure Stability | Measure Dehiscence | TOTAL Score |
|--------------------|-------------------|--------------------|-------------|
| Measure Stability  | X                 | 0.5                | 0.5         |
| Measure Dehiscence | 0.5               | X                  | 0.5         |

Instrumentation Reproducibility

|   | Control Force Distribution | Straight Sternotomy Line | Consistent Alignment of Sterna in Grips | Doesn't Alter Mechanical Properties of Tissue | Biocompatible Materials | TOTAL Score |
|---|----------------------------|--------------------------|---|---|-------------------------|-------------|
| Control Force Distribution                    | X                          | 1                        | 1                                       | 1   | 0                       | 3           |
| Straight Sternotomy Line                      | 0                          | X                        | 1                                       | 0.5   | 0                       | 1.5         |
| Consistent Alignment of Sterna in Grips       | 0                          | 0                        | X                                       | 0.5   | 0                       | 0.5         |
| Doesn't Alter Mechanical Properties of Tissue | 0                          | 0.5                      | 0.5                                     | X   | 0                       | 2           |
| Biocompatible Materials                       | 1                          | 1                        | 1                                       | 1   | X                       | 4           |

Ease of Use

|                               | Few Components | Computerized Data Acquisition | TOTAL Score |
|-------------------------------|----------------|-------------------------------|-------------|
| Few Components                | X              | 0.5                           | 0.5         |
| Computerized Data Acquisition | 0.5            | X                             | 0.5         |

Accommodate Multiple Tissue Samples

|                    | Multiple Rib Pairs | Multiple Types | TOTAL Score |
|--------------------|--------------------|----------------|-------------|
| Multiple Rib Pairs | X                  | 0.5            | 0.5         |
| Multiple Types     | 0.5                | X              | 0.5         |

Time Efficient

|             | Quick Prep | Quick Reset | TOTAL Score |
|-------------|------------|-------------|-------------|
| Quick Prep  | X          | 0.5         | 0.5         |
| Quick Reset | 0.5        | X           | 0.5         |

Pairwise Comparison Charts for Sub-Sub-Objectives for Bilateral Testing Device

Measure Dehiscence

|                     | Anterior Dehiscence | Posterior Splay | TOTAL Score |
|---------------------|---------------------|-----------------|-------------|
| Anterior Dehiscence | X                   | 0.5             | 0.5         |
| Posterior Splay     | 0.5                 | X               | 0.5         |

Accommodate Multiple Rib Pairs

|         | Size | Shape | Density | TOTAL Score |
|---------|------|-------|---------|-------------|
| Size    | X    | 0.5   | 0.5     | 1           |
| Shape   | 0.5  | X     | 0.5     | 1           |
| Density | 0.5  | 0.5   | X       | 1           |

Accommodate Multiple Types of Tissue Samples

|               | Polyurethane | Fresh Cadaver | Fixed Cadaver | TOTAL Score |
|---------------|--------------|---------------|---------------|-------------|
| Polyurethane  | X            | 0.5           | 0.5           | 1           |
| Fresh Cadaver | 0.5          | X             | 0.5           | 1           |
| Fixed Cadaver | 0.5          | 0.5           | X             | 1           |

**APPENDIX F - DR. JANICE LALIKOS' PAIRWISE COMPARISON CHARTS FOR THE BILATERAL TESTING METHOD**

**Pairwise Comparison Chart for Major Design Objectives for Rigid Sternal Device**

|                        | User Friendliness | User Safety | Performance of System | Marketability | Aesthetically pleasing | Durability | TOTAL Score |
|------------------------|-------------------|-------------|-----------------------|---------------|------------------------|------------|-------------|
| User Friendliness      | X                 | 0           | 0                     | 0.5           | 0.5                    | 0          | 1           |
| User Safety            | 0                 | X           | 0                     | 0.5           | 1                      | 0          | 1.5         |
| Performance of System  | 1                 | 1           | X                     | 0.5           | 1                      | 0.5        | 4           |
| Marketability          | 0.5               | 0.5         | 0.5                   | X             | 1                      | 0.5        | 3           |
| Aesthetically pleasing | 0.5               | 1           | 0                     | 0             | X                      | 0          | 1.5         |
| Durability             | 1                 | 1           | 0.5                   | 0.5           | 1                      | X          | 4           |



**Pairwise Comparison Charts for Sub-Objectives for Rigid Sternal Device**

User Friendly

|                         | Ease of Implantation | Ease of Re-entry Access | TOTAL Score |
|-------------------------|----------------------|-------------------------|-------------|
| Ease of Implantation    | X                    | 0.5                     | 0.5         |
| Ease of Re-entry Access | 0.5                  | X                       | 0.5         |

User Safety

|                                       | Minimize Immunogenic Effects | Minimize Damage to Sternum | Minimize Damage to Surrounding Tissue | Prevent Thrombogenic Effects | Biocompatible Materials | No Posterior Protrusions | TOTAL Score |
|---------------------------------------|------------------------------|----------------------------|---------------------------------------|------------------------------|-------------------------|--------------------------|-------------|
| Minimize Immunogenic Effects          | X                            | 0                          | 0                                     | 0.5                          | 0                       | 0                        | 0.5         |
| Minimize Damage to Sternum            | 1                            | X                          | 1                                     | 1                            | 0.5                     | 0.5                      | 4           |
| Minimize Damage to Surrounding Tissue | 1                            | 0                          | X                                     | 1                            | 0.5                     | 0                        | 2.5         |
| Prevent Thrombogenic Effects          | 0.5                          | 0                          | 0                                     | X                            | 0                       | 0                        | 0.5         |
| Biocompatible Materials               | 1                            | 0.5                        | 0.5                                   | 1                            | X                       | 0.5                      | 3.5         |
| No Posterior Protrusions              | 1                            | 0.5                        | 1                                     | 1                            | 0.5                     | X                        | 4           |

Performance of the System

|                              | Maximize Stability of system | Effective in Osteoporotic Bone | Minimize Splay | TOTAL Score |
|------------------------------|------------------------------|--------------------------------|----------------|-------------|
| Maximize Stability of system | X                            | 0.5                            | 1              | 1.5         |
| Effective Osteoporotic Bone  | 0.5                          | X                              | 1              | 1.5         |
| Minimize Splay               | 0                            | 0                              | X              | 0           |

Marketability

|                              | Cost Effective | Better Than Existing Designs | TOTAL Score |
|------------------------------|----------------|------------------------------|-------------|
| Cost Effective               | X              | 0.5                          | 0.5         |
| Better Than Existing Designs | 0.5            | X                            | 0.5         |

Aesthetically Pleasing

|             | Implantable | Not Visible | TOTAL Score |
|-------------|-------------|-------------|-------------|
| Implantable | X           | 0           | 0           |
| Not Visible | 1           | X           | 1           |

Durability

|                           | Withstand Cyclic Fatigue | Withstand Tension | Withstand Compression | Withstand Coughing Forces | Withstand Shear Forces | TOTAL Score |
|---------------------------|--------------------------|-------------------|-----------------------|---------------------------|------------------------|-------------|
| Withstand Cyclic Fatigue  | X                        | 1                 | 1                     | 0.5                       | 0.5                    | 3           |
| Withstand Tension         | 0                        | X                 | 1                     | 0.5                       | 0.5                    | 2           |
| Withstand Compression     | 0                        | 0                 | X                     | 0                         | 0                      | 0           |
| Withstand Coughing Forces | 0.5                      | 0.5               | 1                     | X                         | 1                      | 3           |
| Withstand Shear Forces    | 0.5                      | 0.5               | 1                     | 0                         | X                      | 2           |

**Pairwise Comparison Charts for Sub-Sub-Objectives for Rigid Sternal Device**

Ease of Implantation

|                          | Few Components/<br>Tools | Time Efficient | TOTAL Score |
|--------------------------|--------------------------|----------------|-------------|
| Few Components/<br>Tools | X                        | 0.5            | 0.5         |
| Time Efficient           | 0.5                      | X              | 0.5         |

Maximize Rigidity

|   | Force Distribution | Create Friction<br>Between<br>Plate/Bone | Increase Tensile<br>Stiffness of<br>system | Minimize<br>Dehiscence | TOTAL Score |
|---|--------------------|--|--|------------------------|-------------|
| Force Distribution                            | X                  | 1  | 1  | 0.5                    | 2.5         |
| Create Friction<br>Between<br>Plate/Bone      | 0                  | X  | 0.5  | 0                      | 0.5         |
| Increase<br>Tensile<br>Stiffness of<br>system | 0                  | 0.5                                      | X  | 0                      | 0.5         |
| Minimize<br>Dehiscence                        | 0.5                | 1  | 1  | X                      | 2.5         |

**APPENDIX G - DR. RONALD IGNOTZ'S PAIRWISE COMPARISON CHARTS FOR THE BILATERAL TESTING METHOD**

**Pairwise Comparison Chart for Major Design Objectives for Rigid Sternal Device**

|                                       | <b>1</b><br>User<br>Friendliness | <b>2</b><br>User<br>Safety | <b>3</b><br>Performance<br>of System | <b>4</b><br>Marketability | <b>5</b><br>Aesthetically<br>pleasing | <b>6</b><br>Durability | TOTAL<br>Score |
|---------------------------------------|----------------------------------|----------------------------|--------------------------------------|---------------------------|---------------------------------------|------------------------|----------------|
| <b>1</b><br>User<br>Friendliness      | <b>X</b>                         | <b>1</b>                   | <b>0</b>                             | <b>1</b>                  | <b>1</b>                              | <b>0</b>               | <b>3</b>       |
| <b>2</b><br>User Safety               | <b>0</b>                         | <b>X</b>                   | <b>0</b>                             | <b>1</b>                  | <b>1</b>                              | <b>0</b>               | <b>2</b>       |
| <b>3</b><br>Performance<br>of System  | <b>1</b>                         | <b>1</b>                   | <b>X</b>                             | <b>1</b>                  | <b>1</b>                              | <b>1</b>               | <b>5</b>       |
| <b>4</b><br>Marketability             | <b>0</b>                         | <b>0</b>                   | <b>0</b>                             | <b>X</b>                  | <b>1</b>                              | <b>0</b>               | <b>1</b>       |
| <b>5</b><br>Aesthetically<br>pleasing | <b>0</b>                         | <b>0</b>                   | <b>0</b>                             | <b>0</b>                  | <b>X</b>                              | <b>0</b>               | <b>0</b>       |
| <b>6</b><br>Durability                | <b>1</b>                         | <b>1</b>                   | <b>0</b>                             | <b>1</b>                  | <b>1</b>                              | <b>X</b>               | <b>4</b>       |

**Pairwise Comparison Charts for Sub-Objectives for Rigid Sternal Device**

User Friendly

|                           | 1 Ease of Implantation | 2 Ease of Re-entry Access | TOTAL Score |
|---------------------------|------------------------|---------------------------|-------------|
| 1 Ease of Implantation    | X                      | 0.5                       | 0.5         |
| 2 Ease of Re-entry Access | 0.5                    | X                         | 0.5         |

User Safety

|   | 1 Minimize Immunogenic Effects | 2 Minimize Damage to Sternum | 3 Minimize Damage to Surrounding Tissue | 4 Prevent Thrombogenic Effects | 5 Biocompatible Materials | 6 No Posterior Protrusions | TOTAL Score |
|---|--------------------------------|------------------------------|---|--------------------------------|---------------------------|----------------------------|-------------|
| 1 Minimize Immunogenic Effects          | X                              | 1                            | 1                                       | 0                              | 0                         | 0                          | 2           |
| 2 Minimize Damage to Sternum            | 0                              | X                            | 1                                       | 0                              | 0                         | 0                          | 1           |
| 3 Minimize Damage to Surrounding Tissue | 0                              | 0                            | X                                       | 0                              | 0                         | 0                          | 0           |
| 4 Prevent Thrombogenic Effects          | 1                              | 1                            | 1                                       | X                              | 1                         | 0                          | 4           |
| 5 Biocompatible Materials               | 1                              | 1                            | 1                                       | 0                              | X                         | 0                          | 3           |
| 6 No Posterior Protrusions              | 1                              | 1                            | 1                                       | 1                              | 1                         | X                          | 5           |

Performance of the System

|                                | 1 Maximize Stability of system | 2 Effective in Osteoporotic Bone | 3 Minimize Splay | TOTAL Score |
|--------------------------------|--------------------------------|----------------------------------|------------------|-------------|
| 1 Maximize Stability of system | X                              | 1                                | 1                | 2           |
| 2 Effective Osteoporotic Bone  | 0                              | X                                | 1                | 1           |
| 3 Minimize Splay               | 0                              | 0                                | X                | 0           |

Marketability

|                                | 1 Cost Effective | 2 Better Than Existing Designs | TOTAL Score |
|--------------------------------|------------------|--------------------------------|-------------|
| 1 Cost Effective               | X                | 0.5                            | 0.5         |
| 2 Better Than Existing Designs | 0.5              | X                              | 0.5         |

Aesthetically Pleasing

|               | 1 Implantable | 2 Not Visible | TOTAL Score |
|---------------|---------------|---------------|-------------|
| 1 Implantable | X             | 1             | 1           |
| 2 Not Visible | 0             | X             | 0           |

Durability

|                             | 1 Withstand Cyclic Fatigue | 2 Withstand Tension | 3 Withstand Compression | 4 Withstand Coughing Forces | 5 Withstand Shear Forces | TOTAL Score |
|-----------------------------|----------------------------|---------------------|-------------------------|-----------------------------|--------------------------|-------------|
| 1 Withstand Cyclic Fatigue  | X                          | 1                   | 1                       | 0                           | 1                        | 3           |
| 2 Withstand Tension         | 0                          | X                   | 1                       | 0                           | 0                        | 1           |
| 3 Withstand Compression     | 0                          | 0                   | X                       | 0                           | 0                        | 0           |
| 4 Withstand Coughing Forces | 1                          | 1                   | 1                       | X                           | 1                        | 4           |
| 5 Withstand Shear Forces    | 0                          | 1                   | 1                       | 0                           | X                        | 2           |



**Pairwise Comparison Charts for Sub-Sub-Objectives for Rigid Sternal Device**

Ease of Implantation

|                            | 1 Few Components/<br>Tools | 2 Time Efficient | TOTAL Score |
|----------------------------|----------------------------|------------------|-------------|
| 1 Few Components/<br>Tools | X                          | 0                | 0           |
| 2 Time Efficient           | 1                          | X                | 1           |

Maximize Rigidity

|  | 1 Force Distribution | 2 Create Friction Between Plate/Bone | 3 Increase Tensile Stiffness of system | 4 Minimize Dehiscence | TOTAL Score |
|--|----------------------|--------------------------------------|--|-----------------------|-------------|
| 1 Force Distribution                   | X                    | 1                                    | 0                                      | 0                     | 1           |
| 2 Create Friction Between Plate/Bone   | 0                    | X                                    | 0                                      | 0                     | 0           |
| 3 Increase Tensile Stiffness of system | 1                    | 1                                    | X                                      | 0                     | 2           |
| 4 Minimize Dehiscence                  | 1                    | 1                                    | 1                                      | X                     | 3           |

## APPENDIX H- POWER ANALYSIS

- Test Family: T-test (for 2 groups)
- Means: Difference between two independent means (2 groups)
- Hypothesis 1: Effect size: 0.7 (calculated based on data for 10,000 cycles from Ahn et. al, 2009)
  - Unicortical (with cortical screw): Mean = 1.09 ; SD = 0.63
  - Bicortical (with cortical screw): Mean = 0.67; SD = 0.62
- Allocation ratio  $N2/N1 = 1$
  
- Test Family: ANOVA (for 3 groups)
- Fixed Effects, omnibus, one-way
- Hypothesis 2: effect size = 0.5 (calculated based on data for 15,000 cycles from Ahn et al, 2009)
  - Pedicle: Mean = 0.950 ; SD = 0.37
  - Other types
    - Compression plate: Mean = 1.30; SD = 0.7 (Note: the literature source testes only 2 types of screws with unicortical configuration, so the third type is based on assumption)
    - Locking plate: Mean = 0.70; SD = 0.4
  - Average SD for all 3 groups is considered to be SD=0.5
- Hypothesis 1 and 2: effect size assumed to be large - 0.5

| Power | Hypothesis |                            | # groups | Test Type | effect size  | # samples  | # sterna    |
|-------|------------|----------------------------|----------|-----------|--------------|------------|-------------|
| 95%   | 1          | unicortical/bicortical     | 2        | t-test    | 0.67         | 90         | 15          |
|       | 1          | Thread diameter            | 3        | ANOVA     | 0.6          | 48         | 8           |
|       | 2          | Plate/Screw;<br>plate/bone | 3        | ANOVA     | 0.5          | 66         | 11          |
|       |            |                            |          |           | <b>TOTAL</b> | <b>204</b> | <b>34</b>   |
|       |            |                            |          |           |              |            |             |
| 80%   | 1          | unicortical/bicortical     | 2        | t-test    | 0.7          | 52         | 8.7         |
|       | 1          | Thread diameter            | 3        | ANOVA     | 0.6          | 30         | 5           |
|       | 2          | Plate/Screw;<br>plate/bone | 3        | ANOVA     | 0.5          | 42         | 7           |
|       |            |                            |          |           | <b>TOTAL</b> | <b>124</b> | <b>20.7</b> |
|       |            |                            |          |           |              |            |             |
| 70%   | 1          | unicortical/bicortical     | 2        | t-test    | 0.7          | 40         | 6.7         |
|       | 1          | Thread diameter            | 3        | ANOVA     | 0.6          | 27         | 4.5         |
|       | 2          | Plate/Screw;<br>plate/bone | 3        | ANOVA     | 0.5          | 36         | 6           |
|       |            |                            |          |           | <b>TOTAL</b> | <b>103</b> | <b>17.2</b> |
|       |            |                            |          |           |              |            |             |
| 50%   | 1          | unicortical/bicortical     | 2        | t-test    | 0.7          | 24         | 4           |
|       | 1          | Thread diameter            | 3        | ANOVA     | 0.6          | 18         | 3           |
|       | 2          | Plate/Screw;<br>plate/bone | 3        | ANOVA     | 0.5          | 24         | 4           |
|       |            |                            |          |           | <b>TOTAL</b> | <b>66</b>  | <b>11</b>   |
|       |            |                            |          |           |              |            |             |

**APPENDIX I- MEETING MINUTES WITH UMMS STAKEHOLDERS**

September 29, 2009:

|                        |  |
|------------------------|--|
| <b>TYPE OF MEETING</b> | Initial Sternal Design Group Meeting with the UMMS Surgeons<br><br>Client Meeting 1  |
| <b>ATTENDEES</b>       | <ul style="list-style-type: none"> <li>✓ Lydia Bakalova</li> <li>✓ Steven Chung</li> <li>✓ Hannah Shapiro</li> <li>✓ Roxanne Skowran</li> <li>✓ Prof. George Pins</li> <li>✓ Dr. R. Dunn</li> <li>✓ Dr. Janice Lalikos</li> <li>✓ John Dieselman</li> <li>✓ Prof. Krystyna Gielo-Perczak</li> <li>✓ KLS Representatives</li> </ul> |

The initial client meeting met on September 29, 2009, at the University of Massachusetts Medical School in Dr. Dunn’s office. At the initial meeting representatives of KLS Martin were present due to a prior meeting. The clients had insisted that the KLS representatives attend the meeting due to the relevancy of the project. KLS Martin is a major manufacturing and distribution company for various surgical implants and instruments. The Sternal Design group had presented researched information on characterization of various sternum sizes, various mathematical models showcasing forces within the sternum respiratory muscle mechanics, screw characteristics, screw and plate orientation, innovative plate designs, and novel experimental models used for sternum. There were discussions and questions pertaining to post-operation complications and the importance of cough simulating testing. The KLS Martin representatives had informed the sterna design group that a majority of failure rates were seen mostly in the breathing motion in non-coughing scenarios. The Sternal Design Group had inquired the availability of polyurethane models, screws, plates, and sternum. The clients had assured the Sternal group that they would harvest enough sternums the group needed for significant data.

The KLS Martin representatives had shown interest in providing materials such as plates, screw and polyurethane. Then the KLS Martin representatives had showcased their Sternal Talon device, a rigid sterna fixation system. The Sternal Talon is a titanium ratcheting mechanism that locks the sternum together. The Sternal Talon system has various sizes and caters to patients suffering morbid obesity. During this showcase the KLS Martin representatives had admitted that the Sternal Talon isn't suitable for patients suffering osteoporosis. The Sternal Talon seems to cut into osteoporotic bone when locking together the sternum in place. The clients had addressed the Sternal group that a plate and screw design needed to be made to overcome osteoporotic bone. The clients had shown great interest in a relevant testing method for the previous MQP anti-wobble design and the new information of plate topography. The meeting was then adjourned and contact information was exchanged with the KLS Martin representatives.

November 5, 2009:

|                        |   |
|------------------------|---|
| <b>TYPE OF MEETING</b> | Sternal Design Group Meeting with the UMMS Surgeons<br>Client Meeting 2   |
| <b>ATTENDEES</b>       | <ul style="list-style-type: none"> <li>✓ Lydia Bakalova</li> <li>✓ Steven Chung</li> <li>✓ Hannah Shapiro</li> <li>✓ Roxanne Skowran</li> <li>✓ Prof. George Pins</li> <li>✓ Dr. R. Dunn</li> <li>✓ Dr. Janice Lalikos</li> <li>✓ Dr. Ignatz</li> <li>✓ Prof. Krystyna Gielo-Perczak – conference call</li> </ul> |

The second client meeting was held on November 5, 2009, at the University of Massachusetts Medical School in Dr. Dunn’s office. The Sternal Design group’s presentation was concentrated on the testing device design and the various tests that the group wanted to do with the testing device. Pair wise comparison charts were distributed to the clients for rating of functions. The group had then wanted the clients to clarify the objectives and concerns with the project. The clients had revealed additional information pertaining to the project. The clients had stated that it was hard to define osteoporosis within the patient’s bone because the sternum is a stress bearing bone. Also the device needs to be aesthetically pleasing or the wound will breakdown since the incision site is right on top of the device. The cerclage wires are made of stainless steel resulting in a very cheap product which makes the plate and screw system difficult to market. In order for the screw and plate system to succeed in the market it needs to be target patients with high risk factors such as morbid obesity or for patients exhibiting osteoporotic bone. The study and success of the project must also be data driven to define the value of the product. The clients had also defined splay as a measurable distance. The clients had requested a budget report and a timeline of when testing would start. The meeting was then adjourned.

December 11, 2009:

|                        |  |
|------------------------|--|
| <b>TYPE OF MEETING</b> | Sternal Design Group Meeting with the UMMS Surgeons<br>Client Meeting 3  |
| <b>ATTENDEES</b>       | <ul style="list-style-type: none"><li>✓ Lydia Bakalova</li><li>✓ Steven Chung</li><li>✓ Hannah Shapiro</li><li>✓ Roxanne Skowran</li><li>✓ Prof. George Pins</li><li>✓ Dr. R. Dunn</li><li>✓ Dr. Janice Lalikos</li><li>✓ Dr. Igotz</li><li>✓ Prof. Krystyna Gielo-Perczak</li></ul> |

The third meeting was held on December 11, 2009, at the University of Massachusetts Medical School. The Sternal Design group had presented a final testing design mechanism based on the pair wise comparison charts submitted by the client and the advisors. The hypothesis was better defined since the KLS Martin representatives had provided a list of available plates and screws that they were willing to donate to WPI. It was also mentioned that the KLS Martin representatives weren't able to provide plates with various topography designs and the various pitch lengths were still being investigated. The power analysis presented had revealed that 11 sternum were needed for the tests for compelling data. The clients had thought that it would be difficult to retrieve 11 sternums but was doable. Then a detailed outline of the amount of tests and experiments to be done by the end of the project was presented. Dates were established for doctors to implant the fixation devices onto the samples and the meeting was adjourned.

**APPENDIX J- BUDGET ANALYSIS**

| <b>Item</b>  | <b>Cost per Unit</b> | <b>Number of Units</b> | <b>Total Cost</b> |
|--|----------------------|------------------------|-------------------|
| <b>Tissue Samples</b>                                    |                      |                        |                   |
| Cadaver Sternum  | \$1,500              | 11                     | \$16,500          |
| Low-Density Polyurethane Bone                            | \$20                 | 40                     | \$800             |
| <b>Cortical Screws</b>                                   |                      |                        |                   |
| 11mm Long  | \$62                 | 40                     | \$2,480           |
| 7mm Long<br>*All 2.3mm major diameter                    | \$62                 | 40                     | \$2,480           |
| Major Diameter: 2.0mm                                    | \$48                 | 40                     | \$1,920           |
| Major Diameter: 2.7mm<br>*All 7mm Long/same thread pitch | \$85                 | 40                     | \$3,400           |
| Thread Pitch: 0.5mm<br>(Unavailable)                     | \$0                  | 40                     | \$0               |
| Thread Pitch: 0.6mm<br>(Unavailable)                     | \$0                  | 40                     | \$0               |
| Thread Pitch: 1.0mm<br>(Unavailable)                     | \$0                  | 40                     | \$0               |
| *All 2.3mm major diameter/7mm Long                       |                      |                        |                   |
| Anti-Wobble (unknown pricing yet)                        | \$0                  | 40                     | \$0               |
| Locking<br>*6mm Long                                     | \$108                | 40                     | \$4,320           |
| <b>Plates</b>  |                      |                        |                   |
| Standard Non-Locking 4-Hole Plate                        | \$225                | 20                     | \$4,500           |
| Anti-Wobble  | \$180                | 10                     | \$1,800           |
| Compression  | \$225                | 10                     | \$2,250           |
| Locking  | \$335                | 10                     | \$3,350           |
| Reduced-Contact (Unavailable)                            | \$0                  | 0                      | \$0               |
| <b>Instron Fixture</b>                                   |                      |                        |                   |
| PMMA (in lab already)                                    | \$0                  | 1                      | \$0               |
| Metal Casing/Rails/Alignment Screws                      | \$87                 | 6                      | \$522             |
| PBS (in lab already)                                     | \$0                  | 200                    | \$0               |



| <b>Stakeholder</b> | <b>Total Cost</b> |
|--------------------|-------------------|
| UMMS (Pink)        | \$16,500          |
| KLS (Yellow)       | \$27,300          |
| WPI (Blue)         | \$522             |
| <b>TOTAL</b>       | <b>\$44,322</b>   |

## APPENDIX K - GLOSSARY

|                                 |   |
|---------------------------------|---|
| ANOVA                           | Statistical analysis of variance between different groups of samples  |
| Bilateral testing               | Involves testing on both halves the sternum together rather than just one half  |
| Bone necrosis                   | A disease caused by the loss of blood supply to the bone which results in bone degradation.   |
| Confidence Level                | Measures the likelihood of real and repeatable experimental test  |
| Comminuted Fracture             | Broken bone with several fracture points  |
| Curvature of Sternum            | Lateral curvature seen on the majority of rib pairs on the sternum  |
| Cyclic (Fatigue) Testing        | Mechanical testing where a force is applied to an object in a repetitive rhythm over an extended period of time                                       |
| Dehiscence                      | Separation on the anterior side of the sternum between the two sternum halves   |
| Diaphyseal                      | Pertaining to the shaft of a long bone  |
| Displacement                    | Difference of initial and final position  |
| Effect Size                     | Measure of the strength of the relationship between two variables in a statistical population   |
| Flush                           | Even contact surface on the same plane  |
| Immunogenic Effects             | When an implanted device produces an undesired immune response within the body  |
| Instron Machine                 | Machine that performs cyclic testing  |
| Instrumentation Reproducibility | Ability for the instrumentation to minimize and control variability of data   |
| Locking                         | A feature characterized by the interaction between the threaded screw head and the plate hole allowing the screw to remain perpendicular to the plate |
| Major Diameter                  | The outer diameter of a screw   |
| Minor Diameter                  | Inner/shaft diameter of a screw   |
| Osteoporosis                    | A disease of the bone characterized by the low bone mineral density.  |

|                      |   |
|----------------------|---|
| Pullout strength     | The amount of force needed in order for screws to shear out of the bone resulting in the rigid structure to fail.   |
| Power Analysis       | Statistical method that is used for calculation of the sample size for each hypothesis; it depends on effect size, and confidence level   |
| Rigidity             | Property of an object that resists deformation or movement. For the purposes of this project, it describes the resistance of the entire bone/plate/screw system to movement during breathing. |
| Re-entry             | When surgeons have to re-open the chest cavity after a previous sternotomy that has already been closed   |
| Sample Size          | The number of samples that have to be tested in order to achieve certain confidence level   |
| Splay                | Separation on the posterior side of the sternum between the two sternum halves  |
| Sternotomy           | Surgical procedure where the sternum is cut down the center in order to open up the chest cavity  |
| Test Reproducibility | Ability for a test to produce consistently precise measurements   |
| Thread               | Helical structure that is part of a screw; its purpose is to translate the torque to a linear motion  |
| Thread Depth         | Difference between major and minor screw diameter   |
| Thread Pitch         | The distance measured between 2 threads   |
| Thrombogenic Effects | When an implanted device causes clotting that could block blood vessels   |
| Torque               | Applying a force to a shaft vertically  |

APPENDIX L - DRAWINGS OF FINAL TESTING METHOD DESIGN

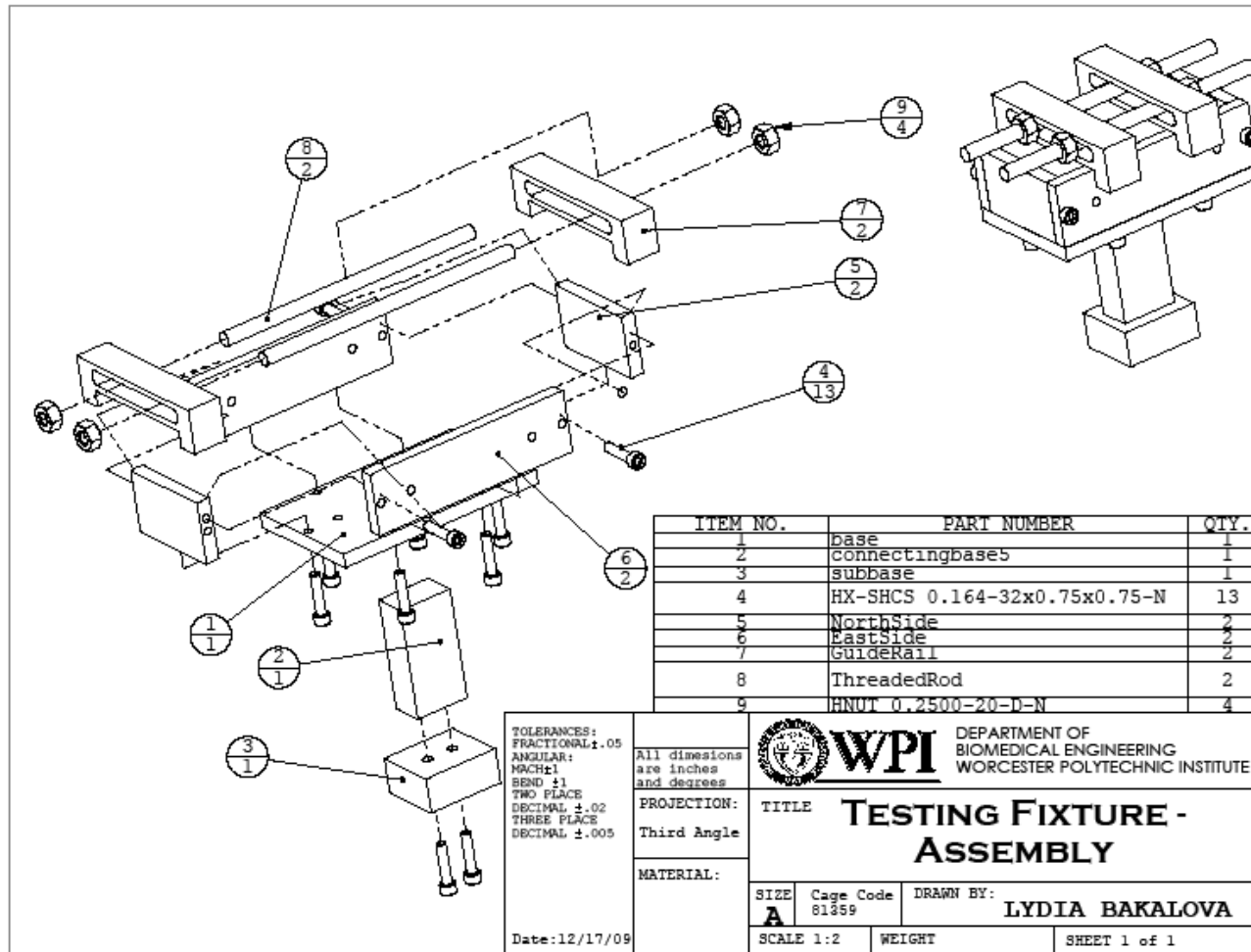

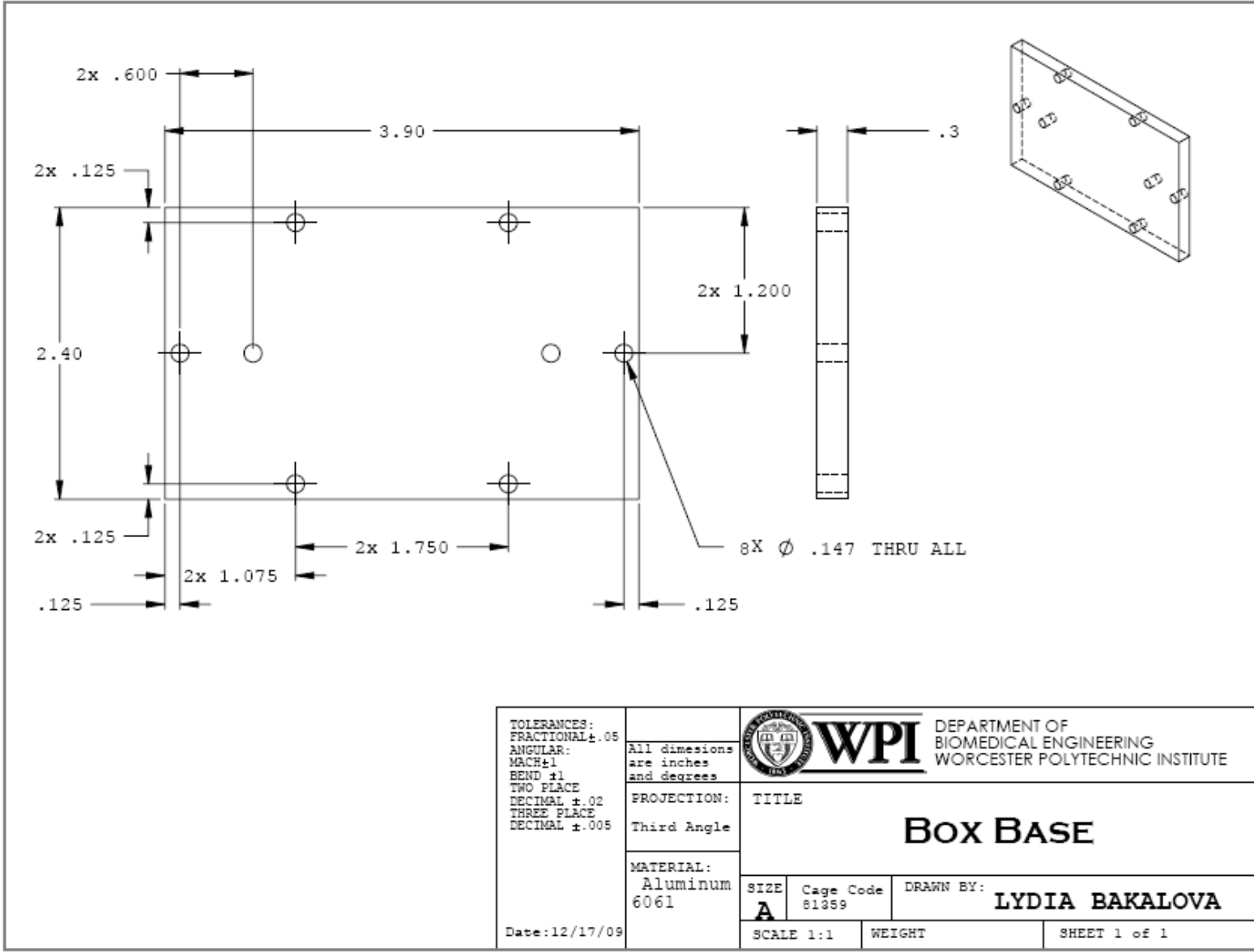

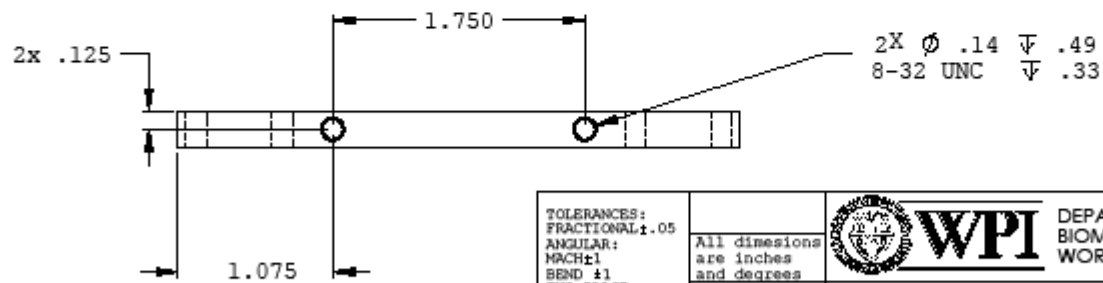
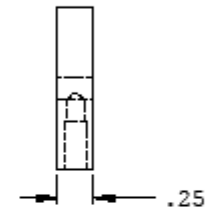
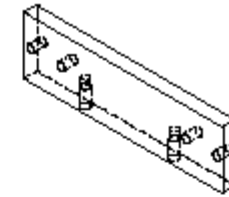
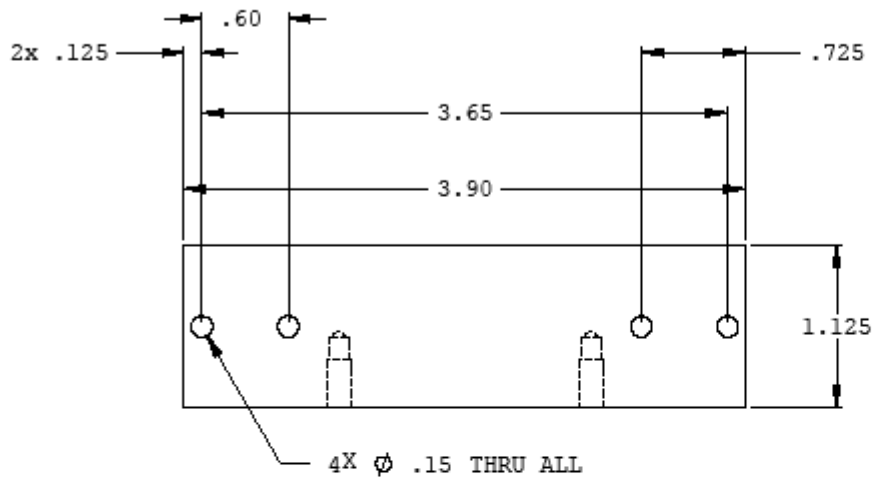

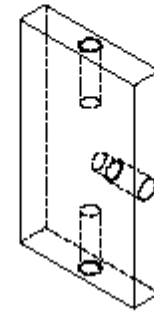
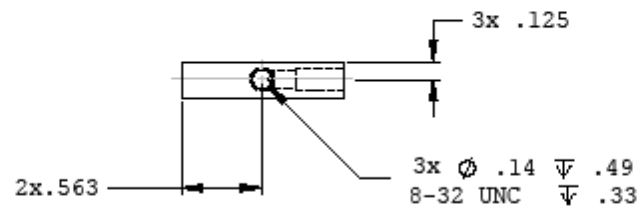

|   |   |   |                                    |
|---|---|---|------------------------------------|
| TOLERANCES:<br>FRACTIONAL: $\pm$ .05<br>ANGULAR:<br>MACH: $\pm$ 1<br>BEND: $\pm$ 1<br>TWO PLACE<br>DECIMAL: $\pm$ .02<br>THREE PLACE<br>DECIMAL: $\pm$ .005 | All dimensions<br>are inches<br>and degrees |  <b>WPI</b> DEPARTMENT OF<br>BIOMEDICAL ENGINEERING<br>WORCESTER POLYTECHNIC INSTITUTE |                                    |
|   |   |   | PROJECTION:<br>Third Angle         |
| MATERIAL:<br><br>Aluminum<br>6061   | SIZE<br><b>A</b>                            | Cage Code<br>81359  | DRAWN BY:<br><b>LYDIA BAKALOVA</b> |
|   | Date: 12/17/09                              | SCALE 1:1   | WEIGHT<br>SHEET 1 of 1             |

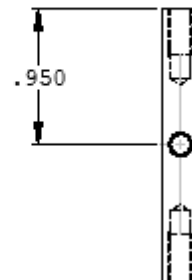
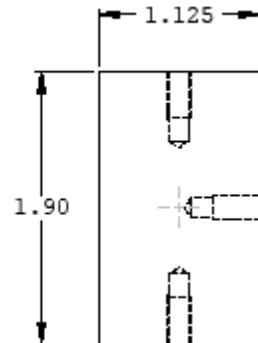

ISO VIEW



|   |   |   |   |
|---|---|---|---|
| TOLERANCES:<br>FRACTIONAL: .05<br>ANGULAR:<br>MACH: ±1<br>BEND: ±1<br>TWO PLACE<br>DECIMAL: ±.02<br>THREE PLACE<br>DECIMAL: ±.005<br>Date: 12/17/09 | All dimensions<br>are inches<br>and degrees |  <b>WPI</b> DEPARTMENT OF<br>BIOMEDICAL ENGINEERING<br>WORCESTER POLYTECHNIC INSTITUTE |   |
|   | PROJECTION:<br>Third Angle                  |   | TITLE<br><h2 style="text-align: center;">SIDE BOX WALL</h2> |
|   | MATERIAL:<br>Aluminum<br>Alloy<br>6061      | SIZE <b>A</b> Cage Code<br>81359  | DRAWN BY:<br><b>LYDIA BAKALOVA</b>                          |
|   |   | SCALE 1:1   | WEIGHT<br>SHEET 1 of 1                                      |

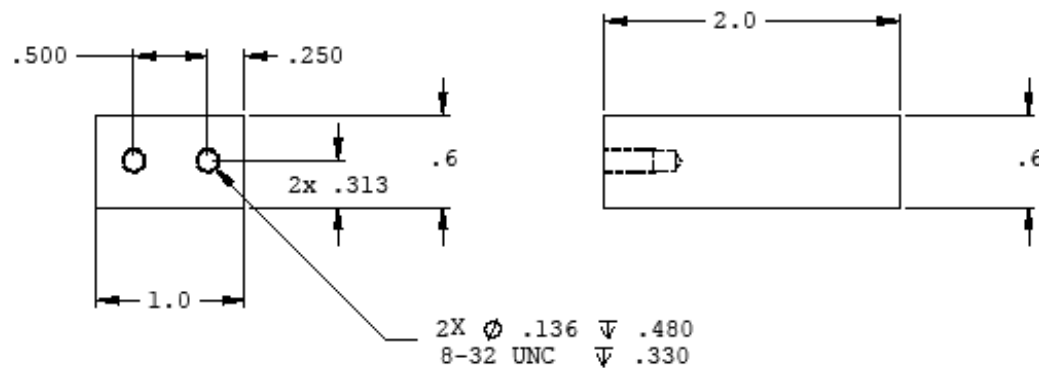
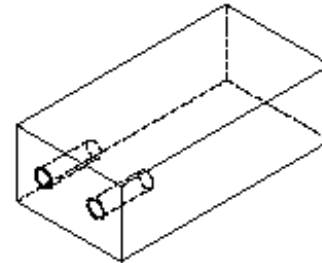

|  |  |   |                           |  |
|--|--|---|---------------------------|--|
| <b>TOLERANCES:</b><br>FRACTIONAL ±.05<br>ANGULAR:<br>MACH ±1<br>BEND ±1<br>TWO PLACE<br>DECIMAL ±.02<br>THREE PLACE<br>DECIMAL ±.005<br><br>Date: 12/17/09 | All dimensions<br>are in inches<br>and degrees |  <b>WPI</b> DEPARTMENT OF<br>BIOMEDICAL ENGINEERING<br>WORCESTER POLYTECHNIC INSTITUTE |                           |  |
|  | <b>PROJECTION:</b><br>Third Angle              |   |                           | <b>TITLE</b><br><h2 style="text-align: center;">CONNECTING BASE<br/>AT GRIP</h2> |
|  | <b>MATERIAL:</b><br>Aluminum<br>6061           | <b>SIZE</b><br><b>A</b>   | <b>Cage Code</b><br>81359 | <b>DRAWN BY:</b><br><b>LYDIA BAKALOVA</b>  |
|  |  | <b>SCALE</b> 1:1  | <b>WEIGHT</b>             | <b>SHEET</b> 1 of 1  |



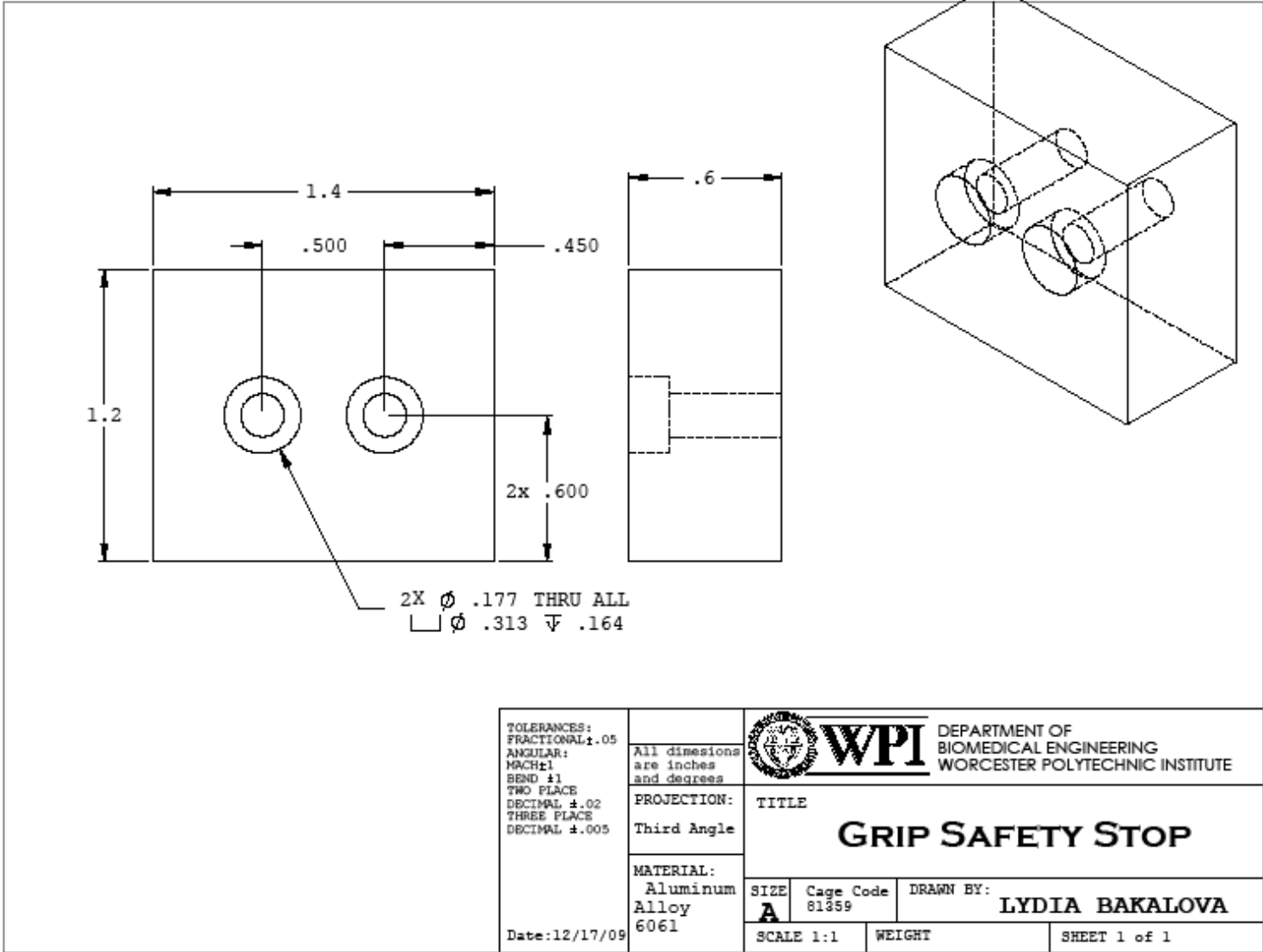

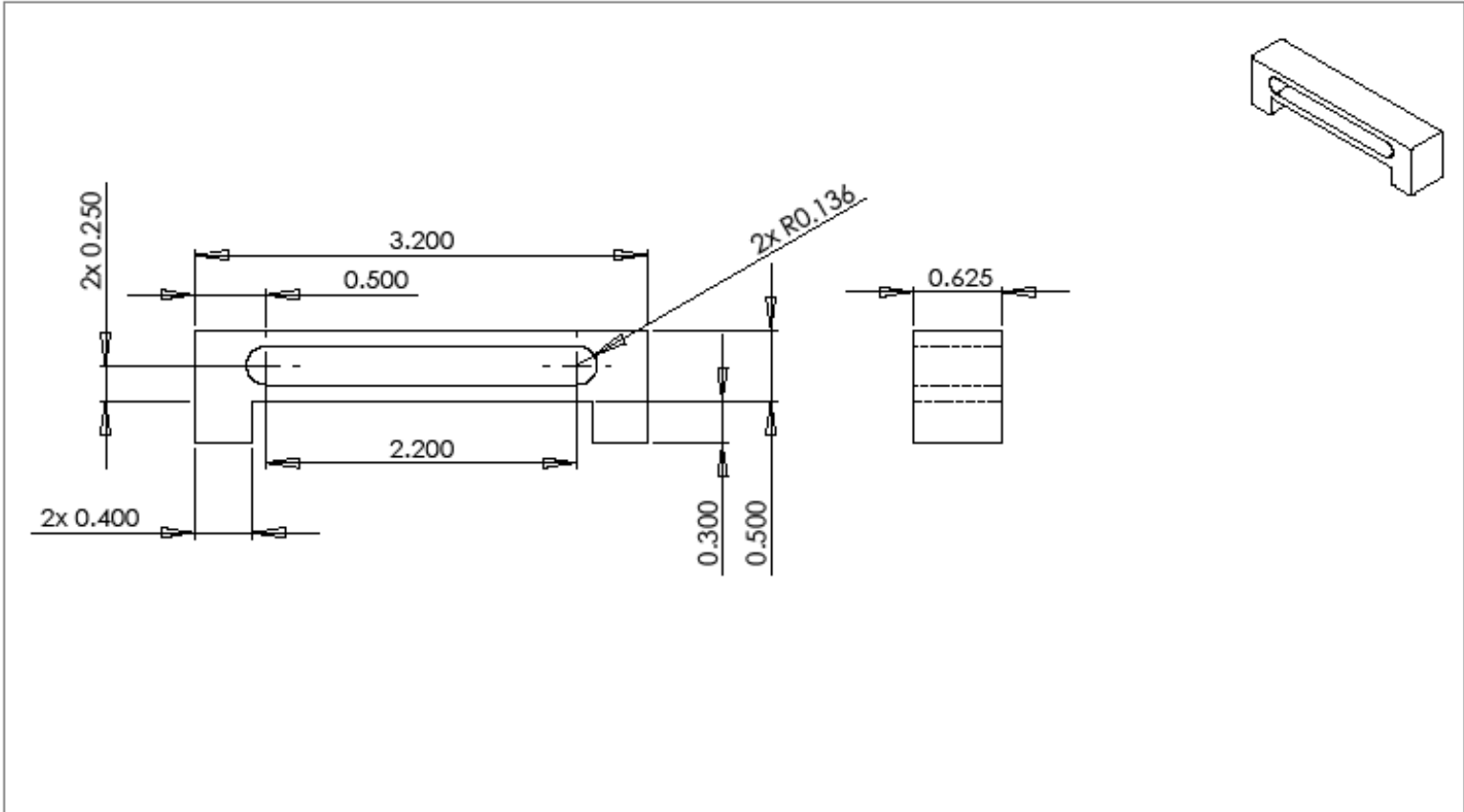

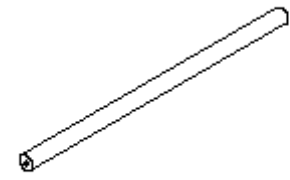

|   |   |   |                    |
|---|---|---|--------------------|
| TOLERANCES:<br>FRACTIONAL $\pm 0.05$<br>ANGULAR:<br>MACH $\pm 1$<br>BEND $\pm 1$<br>TWO PLACE<br>DECIMAL $\pm 0.02$<br>THREE PLACE<br>DECIMAL $\pm 0.005$ | All dimensions<br>are inches<br>and degrees |  <b>WPI</b> DEPARTMENT OF<br>BIOMEDICAL ENGINEERING<br>WORCESTER POLYTECHNIC INSTITUTE |                    |
|   | PROJECTION:<br>Third Angle                  | TITLE<br><h2 style="text-align: center;">GUIDING RAIL</h2>  |                    |
|   | MATERIAL:<br>Aluminum<br>Alloy 6061         | SIZE<br><b>A</b>  | Cage Code<br>61359 |
| Date: 12/17/09  | SCALE 1:1                                   | WEIGHT  | SHEET 1 of 1       |

1/4 - 20 THREADED ROD



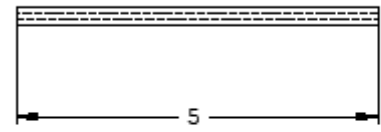









ISO VIEW











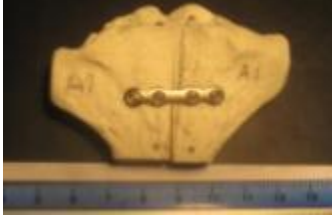
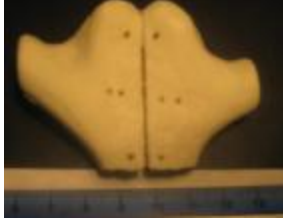











|   |   |   |                    |                                    |
|---|---|---|--------------------|------------------------------------|
| TOLERANCES:<br>FRACTIONAL ±.05<br>ANGULAR:<br>MACH ±1<br>BEND ±1<br>TWO PLACE<br>DECIMAL ±.02<br>THREE PLACE<br>DECIMAL ±.005 | All dimensions<br>are inches<br>and degrees |  <b>WPI</b> DEPARTMENT OF<br>BIOMEDICAL ENGINEERING<br>WORCESTER POLYTECHNIC INSTITUTE |                    |                                    |
|   | PROJECTION:<br>Third Angle                  | TITLE<br><h2 style="text-align: center;">THREADED BAR</h2>  |                    |                                    |
| Date: 12/17/09  | MATERIAL:                                   | SIZE<br><b>A</b>  | Cage Code<br>81359 | DRAWN BY:<br><b>LYDIA BAKALOVA</b> |
|   |   | SCALE 1:1   | WEIGHT             | SHEET 1 of 1                       |













APPENDIX M – FULL LIST OF HARDWARE PROVIDED BY KLS MARTIN INC.

| Description   | Picture  | Total number |
|---|--|--------------|
| Cross-drive bone screw<br>2.3mm DIA x 11mm Ti-6Al-4V Titanium alloy           |    | 40           |
| Cross-drive bone screw<br>2.3mm DIA x 7mm Ti-6Al-4V Titanium alloy            |    | 40           |
| Cross-drive mini bone screw<br>2.0mm DIA x 7mm Ti-6Al-4V Titanium alloy       |    | 40           |
| Cross-drive bone screw<br>2.7mm DIA x 8mm Ti-6Al-4V Titanium alloy            |  | 40           |
| Locking Cross-drive bone screw<br>2.3mm DIA x 7mm Ti-6Al-4V Titanium alloy    |  | 40           |
| Fracture plate, 4-hole, 30mm, 2.3mm system, Ti-6Al-4V                         |  | 10           |
| Fracture plate, 4-hole, 28mm, non-compression, 2.3mm system, Ti-6Al-4V        |  | 20           |
| Locking Fracture plate, 4-hole, 28mm, non-compression, 1.5mm thick, Ti-6Al-4V |  | 10           |
| Fracture plate, 4-hole, 35mm, 2.7mm system, Ti-6Al-4V                         |  | 10           |

APPENDIX N - FULL LIST OF ASSEMBLED STERNAL RIB SAMPLES









| Sample ID | Description   | Anterior   | Posterior   |
|-----------|---|--|---|
| A1        | <ul style="list-style-type: none"> <li>• Standard plate</li> <li>• Screw: 7mm long; 2.3mm diameter</li> </ul> |    |    |
| A2        | <ul style="list-style-type: none"> <li>• Standard plate</li> <li>• Screw: 7mm long; 2.3mm diameter</li> </ul> |    |    |
| A3        | <ul style="list-style-type: none"> <li>• Standard plate</li> <li>• Screw: 7mm long; 2.3mm diameter</li> </ul> |   |   |
| A4        | <ul style="list-style-type: none"> <li>• Standard plate</li> <li>• Screw: 7mm long; 2.3mm diameter</li> </ul> |  |  |
| A5        | <ul style="list-style-type: none"> <li>• Standard plate</li> <li>• Screw: 7mm long; 2.3mm diameter</li> </ul> |  |  |
|           |   |  |   |

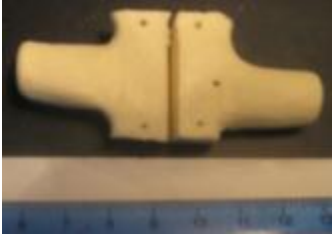







|    |  |  |   |
|----|--|--|---|
| B1 | <ul style="list-style-type: none"> <li>• Standard plate</li> <li>• Screw: 11mm long; 2.3mm diameter</li> </ul> |    |    |
| B2 | <ul style="list-style-type: none"> <li>• Standard plate</li> <li>• Screw: 11mm long; 2.3mm diameter</li> </ul> |    |    |
| B3 | <ul style="list-style-type: none"> <li>• Standard plate</li> <li>• Screw: 11mm long; 2.3mm diameter</li> </ul> |    |    |
| B4 | <ul style="list-style-type: none"> <li>• Standard plate</li> <li>• Screw: 11mm long; 2.3mm diameter</li> </ul> |   |   |
| B5 | <ul style="list-style-type: none"> <li>• Standard plate</li> <li>• Screw: 11mm long; 2.3mm diameter</li> </ul> |  |  |
|    |  |  |   |
| C1 | <ul style="list-style-type: none"> <li>• Standard plate</li> <li>• Screw: 7mm long; 2.0mm diameter</li> </ul>  |  |  |



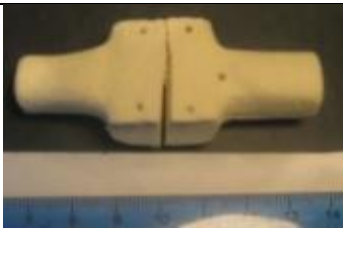
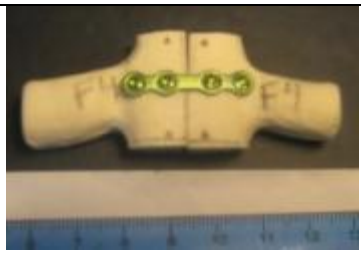







|    |   |  |   |
|----|---|--|---|
| C2 | <ul style="list-style-type: none"> <li>• Standard plate</li> <li>• Screw: 7mm long; 2.0mm diameter</li> </ul>         |    |    |
| C3 | <ul style="list-style-type: none"> <li>• Standard plate</li> <li>• Screw: 7mm long; 2.0mm diameter</li> </ul>         |    |    |
| C4 | <ul style="list-style-type: none"> <li>• Standard plate</li> <li>• Screw: 7mm long; 2.3mm diameter</li> </ul>         |    |    |
| C5 | <ul style="list-style-type: none"> <li>• Standard plate</li> <li>• Screw: 7mm long; 2.3mm diameter</li> </ul>         |   |   |
| C6 | <ul style="list-style-type: none"> <li>• Standard plate</li> <li>• Screw: 7mm long; 2.3mm diameter</li> </ul>         |  |  |
|    |   |  |   |
| D1 | <ul style="list-style-type: none"> <li>• Standard plate (2.7mm)</li> <li>• Screw: 8mm long; 2.7mm diameter</li> </ul> |  |  |



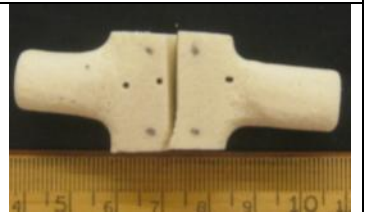

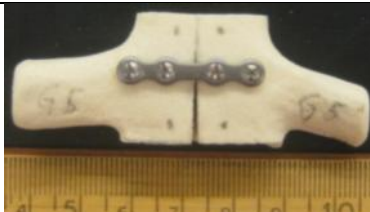

|    |   |  |   |
|----|---|--|---|
| D2 | <ul style="list-style-type: none"> <li>• Standard plate (2.7mm)</li> <li>• Screw: 8mm long; 2.7mm diameter</li> </ul> |    |    |
| D3 | <ul style="list-style-type: none"> <li>• Standard plate (2.7mm)</li> <li>• Screw: 8mm long; 2.7mm diameter</li> </ul> | Stripped screws  | Stripped screws   |
| D4 | <ul style="list-style-type: none"> <li>• Locking plate</li> <li>• Screw: 7mm long; 2.3 mm diameter</li> </ul>         |    |    |
| D5 | <ul style="list-style-type: none"> <li>• Locking plate</li> <li>• Screw: 7mm long; 2.3 mm diameter</li> </ul>         |   |   |
| D6 | <ul style="list-style-type: none"> <li>• Locking plate</li> <li>• Screw: 7mm long; 2.3 mm diameter</li> </ul>         |  |  |
|    |   |  |   |
| E1 | <ul style="list-style-type: none"> <li>• Compression plate</li> <li>• Screw: 7mm long; 2.3mm diameter</li> </ul>      |  |  |



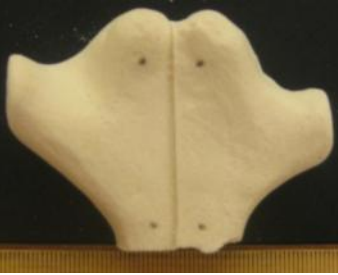
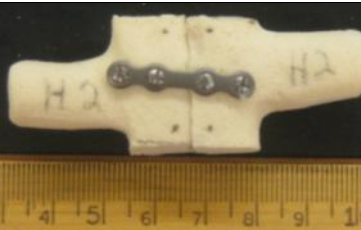

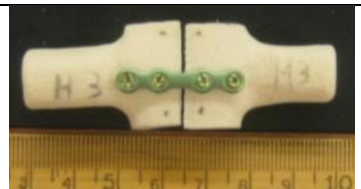
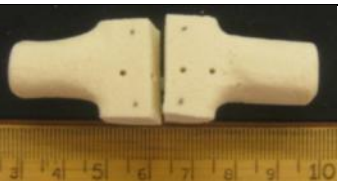
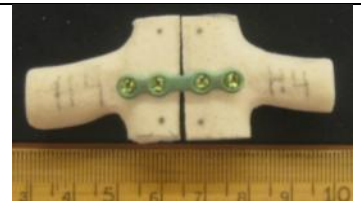
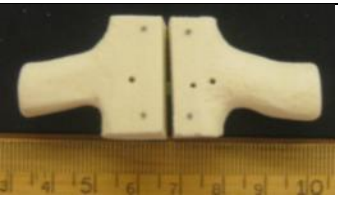
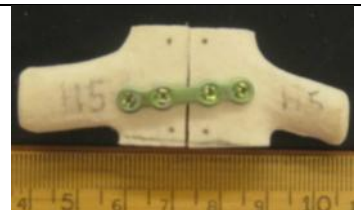





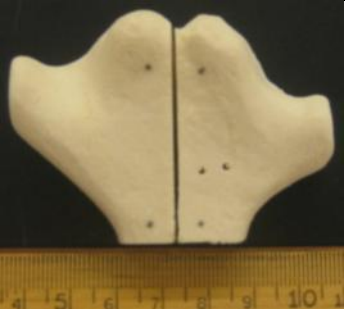
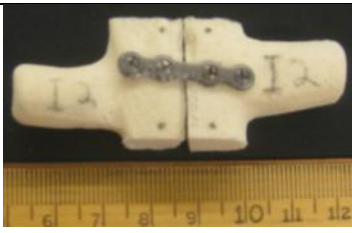
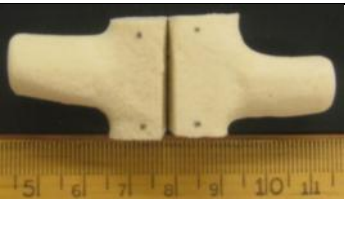
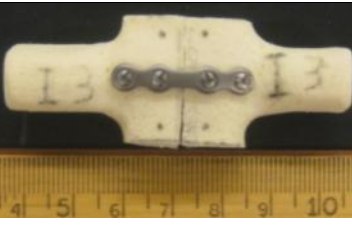
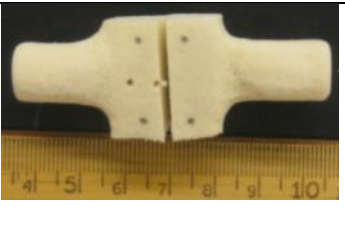

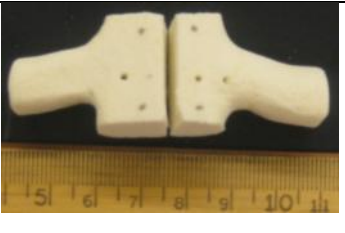
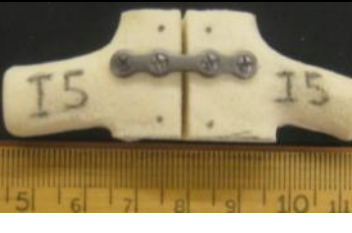



|    |  |  |   |
|----|--|--|---|
| E2 | <ul style="list-style-type: none"> <li>• Compression plate</li> <li>• Screw: 7mm long; 2.3mm diameter</li> </ul> |    |    |
| E3 | <ul style="list-style-type: none"> <li>• Compression plate</li> <li>• Screw: 7mm long; 2.3mm diameter</li> </ul> |    |    |
| E4 | <ul style="list-style-type: none"> <li>• Compression plate</li> <li>• Screw: 7mm long; 2.3mm diameter</li> </ul> |    |    |
| E5 | <ul style="list-style-type: none"> <li>• Compression plate</li> <li>• Screw: 7mm long; 2.3mm diameter</li> </ul> |   |   |
|    |  |  |   |
| F1 | <ul style="list-style-type: none"> <li>• Locking plate</li> <li>• Screw: 7mm long; 2.3 mm diameter</li> </ul>    |  |  |

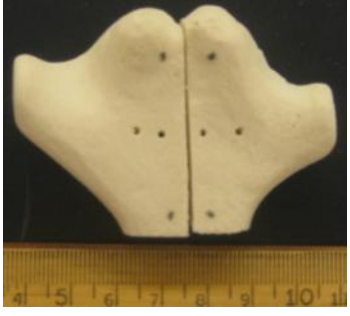

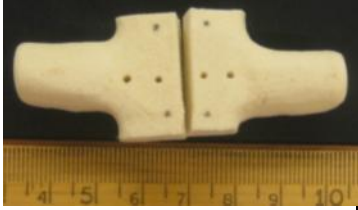



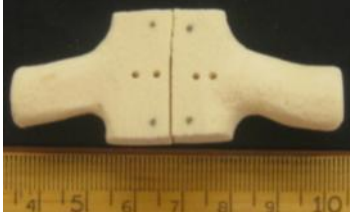
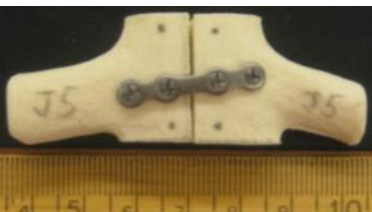



|    |  |  |   |
|----|--|--|---|
| F2 | <ul style="list-style-type: none"> <li>• Locking plate</li> <li>• Screw: 7mm long; 2.3 mm diameter</li> </ul>    |    |    |
| F3 | <ul style="list-style-type: none"> <li>• Locking plate</li> <li>• Screw: 7mm long; 2.3 mm diameter</li> </ul>    |    |    |
| F4 | <ul style="list-style-type: none"> <li>• Locking plate</li> <li>• Screw: 7mm long; 2.3 mm diameter</li> </ul>    |    |    |
| F5 | <ul style="list-style-type: none"> <li>• Compression plate</li> <li>• Screw: 7mm long; 2.3mm diameter</li> </ul> |  |  |
| F6 | <ul style="list-style-type: none"> <li>• Compression plate</li> <li>• Screw: 7mm long; 2.3mm diameter</li> </ul> |  |  |
|    |  |  |   |

|           |  |  |   |
|-----------|--|--|---|
| <p>G1</p> | <ul style="list-style-type: none"> <li>• Standard plate</li> <li>• Screw: 11mm long; 2.3mm diameter</li> </ul> |    |    |
| <p>G2</p> | <ul style="list-style-type: none"> <li>• Standard plate</li> <li>• Screw: 11mm long; 2.3mm diameter</li> </ul> |    |    |
| <p>G3</p> | <ul style="list-style-type: none"> <li>• Standard plate</li> <li>• Screw: 11mm long; 2.3mm diameter</li> </ul> |    |    |
| <p>G4</p> | <ul style="list-style-type: none"> <li>• Standard plate</li> <li>• Screw: 11mm long; 2.3mm diameter</li> </ul> |   |   |
| <p>G5</p> | <ul style="list-style-type: none"> <li>• Standard plate</li> <li>• Screw: 11mm long; 2.3mm diameter</li> </ul> |  |  |
| <p>G6</p> | <ul style="list-style-type: none"> <li>• Standard plate</li> <li>• Screw: 11mm long; 2.3mm diameter</li> </ul> |  |  |
|           |  |  |   |

|           |  |  |   |
|-----------|--|--|---|
| <p>H1</p> | <ul style="list-style-type: none"> <li>• Standard plate</li> <li>• Screw: 11mm long; 2.3mm diameter</li> </ul> |    |    |
| <p>H2</p> | <ul style="list-style-type: none"> <li>• Standard plate</li> <li>• Screw: 11mm long; 2.3mm diameter</li> </ul> |    |    |
| <p>H3</p> | <ul style="list-style-type: none"> <li>• Locking plate</li> <li>• Screw: 7mm long; 2.3 mm diameter</li> </ul>  |    |    |
| <p>H4</p> | <ul style="list-style-type: none"> <li>• Locking plate</li> <li>• Screw: 7mm long; 2.3 mm diameter</li> </ul>  |   |   |
| <p>H5</p> | <ul style="list-style-type: none"> <li>• Locking plate</li> <li>• Screw: 7mm long; 2.3 mm diameter</li> </ul>  |  |  |
| <p>H6</p> | <ul style="list-style-type: none"> <li>• Locking plate</li> <li>• Screw: 7mm long; 2.3 mm diameter</li> </ul>  |  |  |
|           |  |  |   |

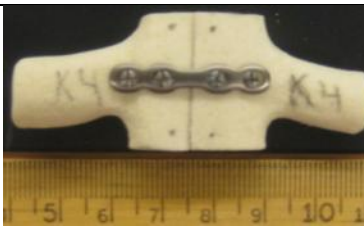

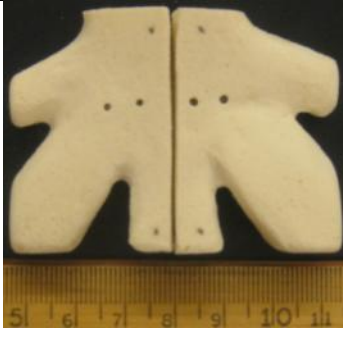

|           |   |  |   |
|-----------|---|--|---|
| <p>I1</p> | <ul style="list-style-type: none"> <li>• Standard plate</li> <li>• Screw: 7mm long; 2.0mm diameter</li> </ul> |    |    |
| <p>I2</p> | <ul style="list-style-type: none"> <li>• Standard plate</li> <li>• Screw: 7mm long; 2.0mm diameter</li> </ul> |    |    |
| <p>I3</p> | <ul style="list-style-type: none"> <li>• Standard plate</li> <li>• Screw: 7mm long; 2.0mm diameter</li> </ul> |    |    |
| <p>I4</p> | <ul style="list-style-type: none"> <li>• Standard plate</li> <li>• Screw: 7mm long; 2.0mm diameter</li> </ul> |  |  |
| <p>I5</p> | <ul style="list-style-type: none"> <li>• Standard plate</li> <li>• Screw: 7mm long; 2.3mm diameter</li> </ul> |  |  |
| <p>I6</p> | <ul style="list-style-type: none"> <li>• Standard plate</li> <li>• Screw: 7mm long; 2.3mm diameter</li> </ul> |  |  |

| J1 | <ul style="list-style-type: none"> <li>• Standard plate</li> <li>• Screw: 7mm long; 2.3mm diameter</li> </ul> |    |    |
|----|---|--|---|
| J2 | <ul style="list-style-type: none"> <li>• Standard plate</li> <li>• Screw: 7mm long; 2.3mm diameter</li> </ul> |    |    |
| J3 | <ul style="list-style-type: none"> <li>• Standard plate</li> <li>• Screw: 7mm long; 2.3mm diameter</li> </ul> |   |   |
| J4 | <ul style="list-style-type: none"> <li>• Standard plate</li> <li>• Screw: 7mm long; 2.3mm diameter</li> </ul> |  |  |
| J5 | <ul style="list-style-type: none"> <li>• Standard plate</li> <li>• Screw: 7mm long; 2.3mm diameter</li> </ul> |  |  |

|           |  |  |   |
|-----------|--|--|---|
| <p>J6</p> | <ul style="list-style-type: none"> <li>• Standard plate</li> <li>• Screw: 7mm long; 2.3mm diameter</li> </ul>    |    |    |
|           |  |  |   |
| <p>K2</p> | <ul style="list-style-type: none"> <li>• Compression plate</li> <li>• Screw: 7mm long; 2.3mm diameter</li> </ul> |    |    |
| <p>K3</p> | <ul style="list-style-type: none"> <li>• Compression plate</li> <li>• Screw: 7mm long; 2.3mm diameter</li> </ul> |   |   |
| <p>K4</p> | <ul style="list-style-type: none"> <li>• Compression plate</li> <li>• Screw: 7mm long; 2.3mm diameter</li> </ul> |  |  |
| <p>K5</p> | <ul style="list-style-type: none"> <li>• Compression plate</li> <li>• Screw: 7mm long; 2.3mm diameter</li> </ul> |  |  |

|           |  |  |   |
|-----------|--|--|---|
| <p>K6</p> | <ul style="list-style-type: none"> <li>• Compression plate</li> <li>• Screw: 7mm long; 2.3mm diameter</li> </ul> |  |  |
|-----------|--|--|---|



|              |  |  |
|--------------|--|--|
| <p>CAD 1</p> | <ul style="list-style-type: none"> <li>• Standard plate</li> <li>• Screw: 7mm long; 2.3mm diameter</li> </ul>  |    |
| <p>CAD 2</p> | <ul style="list-style-type: none"> <li>• Standard plate</li> <li>• Screw: 7mm long; 2.3mm diameter</li> </ul>  |   |
| <p>CAD 3</p> | <ul style="list-style-type: none"> <li>• Standard plate</li> <li>• Screw: 7mm long; 2.3mm diameter</li> </ul>  |  |
| <p>CAD 4</p> | <ul style="list-style-type: none"> <li>• Standard plate</li> <li>• Screw: 11mm long; 2.3mm diameter</li> </ul> |  |
| <p>CAD 5</p> | <ul style="list-style-type: none"> <li>• Standard plate</li> <li>• Screw: 11mm long; 2.3mm diameter</li> </ul> |  |



|       |   |  |
|-------|---|--|
| CAD 6 | <ul style="list-style-type: none"><li>• Standard plate</li><li>• Screw: 11mm long;<br/>2.3mm diameter</li></ul> |  |
|-------|---|--|

APPENDIX O – PROCEDURE FOR SAMPLE POTTING AND LOADING IN THE INSTRON

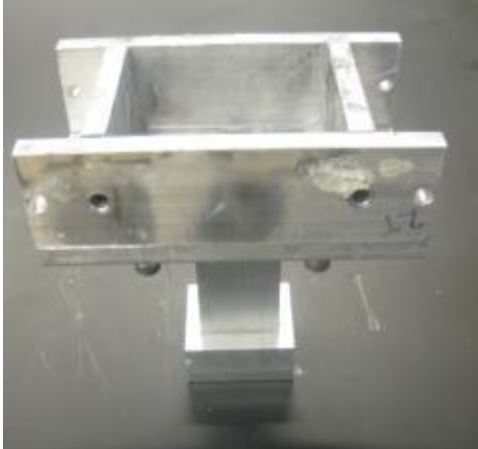
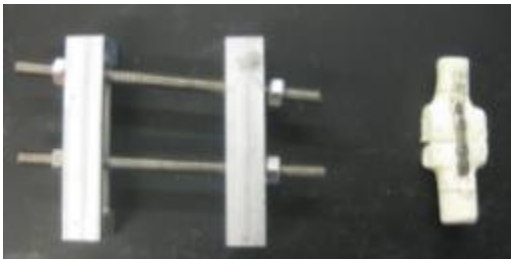
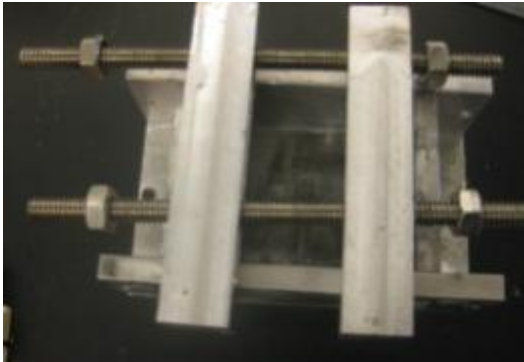
| Procedure Description  | Photo  |
|--|--|
| <p>Obtain top fixture from one of the sets.</p>  |    |
| <ul style="list-style-type: none"><li>• Obtain set of guiding rails and threaded rods with hex nuts.</li><li>• Obtain sternal rib pair assembled with sternal hardware</li></ul> |   |
| <ul style="list-style-type: none"><li>• Position guiding rail system on top of the fixture</li></ul>   |  |

- Create small grooves in the sternal rib portion that will be potted in the epoxy to prevent slippage of the sample from the putty



- Vacuum the sample thoroughly to remove any polyurethane dust or loose particles



- Insert the sample within the guiding rails with the right anatomical rib being inside the fixture.
- The cuts that separate the rib pairs are facing the flat sides of the guiding rails.
- Compress the rails towards each other in order to ensure sample alignment within the rails
- Tighten the 4 hex nuts on the threaded bars in order to fix the sample position.

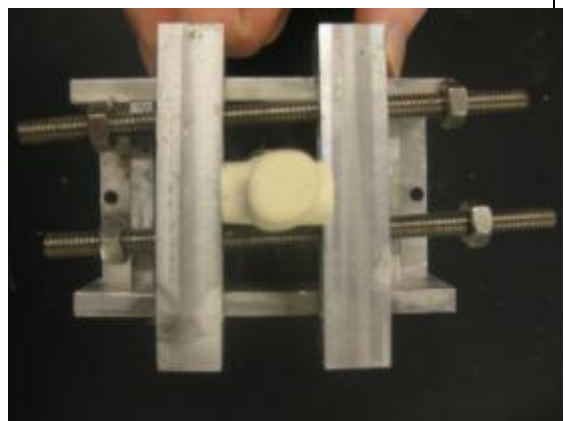

- Sternotomy cut of the sample is completely aligned with the top edge of the fixture.

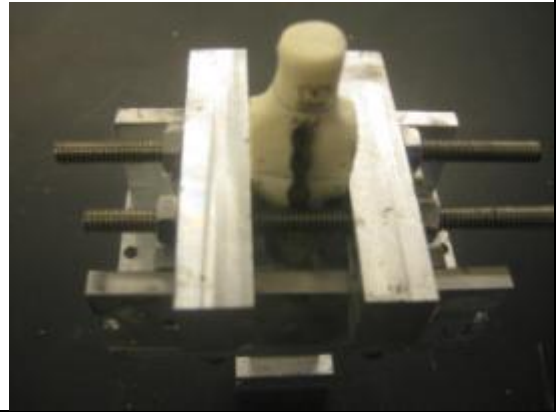

- For epoxy putty preparation obtain “Bondo All-purpose epoxy Putty”, measuring cup (enclosed with the putty kit); mixing cup, and tong depressor



- Measure 1 scoop of the epoxy



- Place one strip of the “Bondo” hardener (enclosed with the epoxy kit) over the scoop of epoxy



- Scoop out the materials and place in the mixing cup



- Mix thoroughly 1.5 scoops of the epoxy with 1.5 stripes of the hardener for 1-2 minutes.



- Pour the mixture into the fixture.

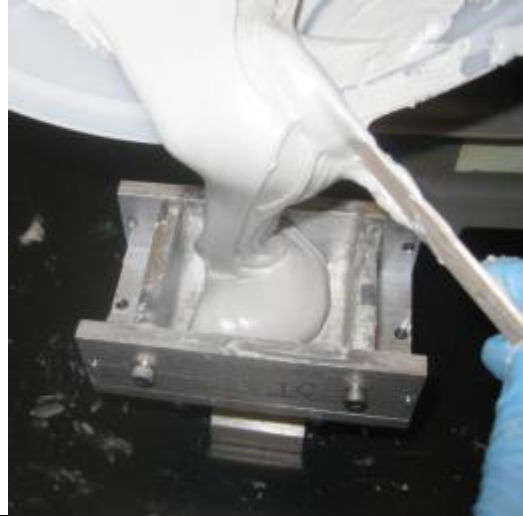

- Fill the fixture to the top



- Align guiding rails with the edges of the fixture

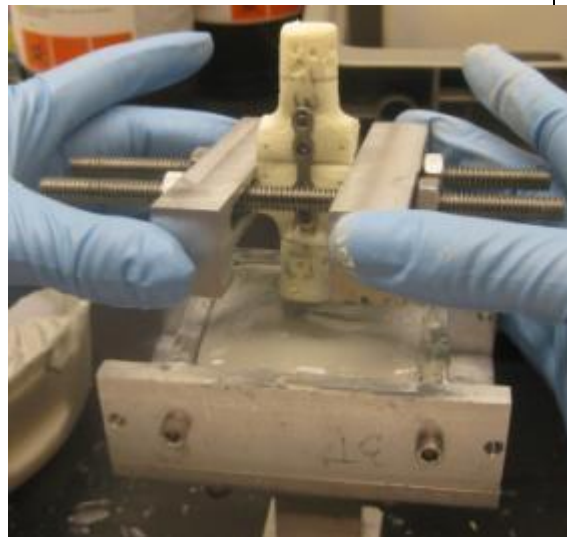

- Position rails on the long sides of the fixtures.
- The sample sinks into the epoxy mixture

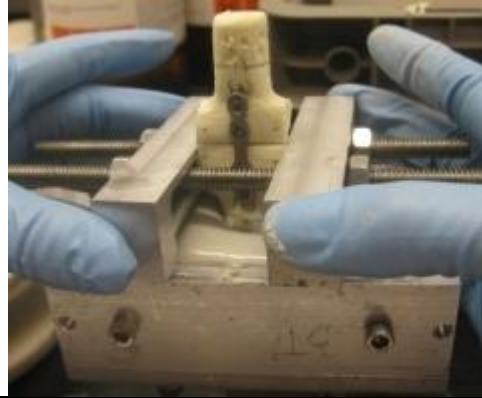

- Verify the epoxy reaches the line drawn on the sternal rib
- Leave the epoxy to harden for 5-10 min and then remove the guiding rail system before the epoxy is completely dry

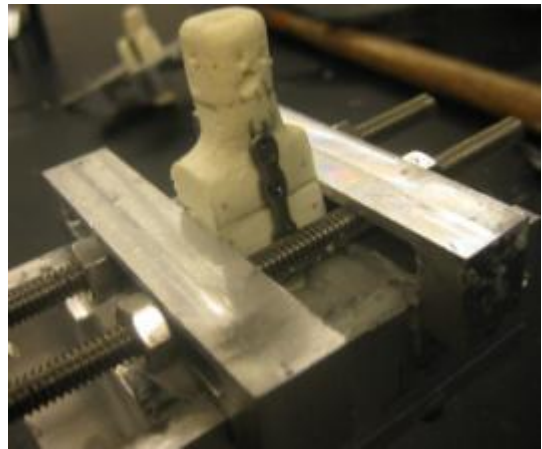

- Write the code ID of the sample on autoclave tape and stick it to both long sides of the fixture



- Load the potted fixture in the top Instron grip



- Tighten the grip using the side knobs

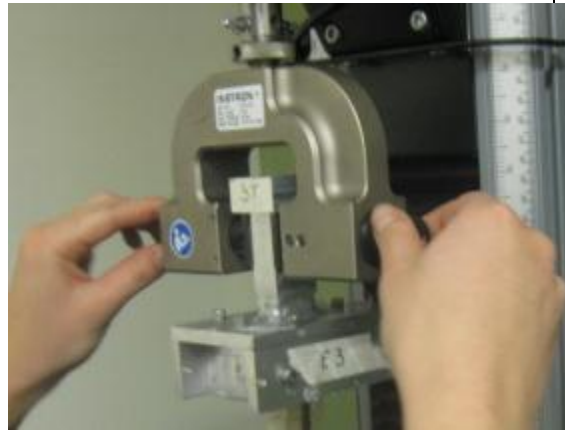



- Execute the same mixing putty procedure and fill up the bottom fixture of the set.
- Place in the machine and tighten.

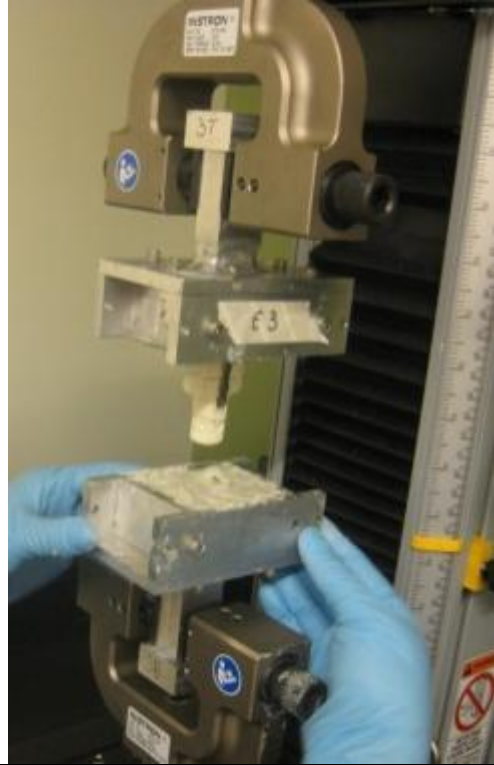

- Jog the machine load cell down in order to sink the sample into the bottom fixture



- Once the putty reaches the line on the



- Once the putty is hardened, 4 C-clamps have to be positioned (2 on top and 2 on bottom fixture) to hold the putty from slippage out of the fixture



- Take picture before and after the test of the anterior and posterior side. (NOTE: ruler has to be held in line with the sample for best estimation of the distance between markers)



## Load Frame Components

The graphics shown in this section display the various components for the single column and dual column load frames. Refer to the graphic displaying your specific model type in order to familiarize yourself with the various components of your frame. The following sections briefly describe the various components.

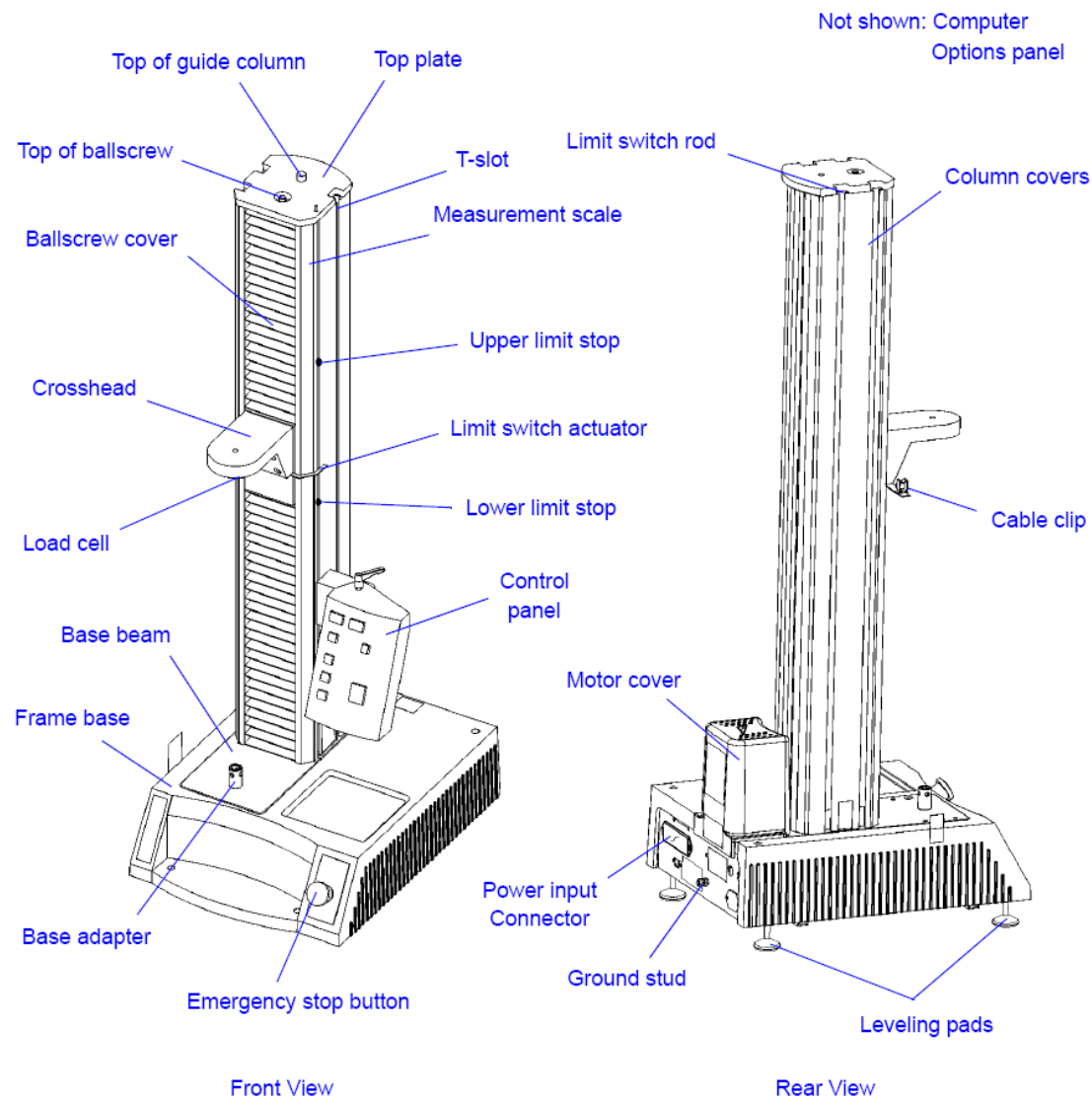

Figure 1-1. 5540 Series Load Frame

Table 2-9. Series 5540 System Performance (Continued)

| Parameter   | Specifications   |            |            |
|---|--|------------|------------|
|   | 5542   | 5543       | 5544       |
| Maximum speed<br>at Full load<br>mm/min<br>in/min | 1000<br>40   | 1000<br>40 | 1000<br>40 |
| Return speed<br>mm/min<br>in/min                  | 1500<br>60   | 1500<br>60 | 1500<br>60 |
| Crosshead<br>speed accuracy                       | ± 0.1% at steady state and no load measured over 100 mm or 30 seconds,<br>whichever is greater.                              |            |            |
| Position accuracy<br>(Extension)                  | Under no load conditions, equal or less than ± 0.02 mm (0.0008 in) or ±<br>0.05% of displayed reading, whichever is greater. |            |            |
| Position repeatability                            | ± 0.015 mm (0.0006 in)   |            |            |
| Load measurement accuracy                         | ± 0.4% of reading down to 1/100 of load cell capacity.<br>± 0.5% of reading down to 1/250 of load cell capacity.             |            |            |
| Strain measurement<br>accuracy                    | ± 0.5% of reading down to 1/50 of full scale with ASTM E83 class B or ISO<br>9513 class 0.5 extensometer.                    |            |            |
| Crosshead<br>position control<br>resolution       | 0.156 µm   | 0.156 µm   | 0.208 µm   |
| Acceleration time,<br>0 to top speed              | 120 ms   |            |            |
| Emergency stop time                               | 100 ms   | 100 ms     | 100 ms     |

## 1. Purpose and Scope

1.1. The purpose of this testing protocol is to compare how different qualities of sternum fixation systems affect the overall performance of the repaired sternum. In addition, this test protocol serves to standardize the way in which samples are tested for further research and understanding of the gathered data. The scope of this testing will include cortical sternum screws in various lengths and diameters, non-locking systems, locking systems, anti-wobble systems and compressive systems.

## 2. Requirements

### 2.1. Description

2.1.1. There are several qualities which a rigid sternal fixation system must meet in order to be clinically relevant and minimally harmful to the patient. The most important quality that must be reached is that the fixation system does not allow the sternum halves to separate more than 1mm per sternal half. When the sternum is separated by more than this amount, bone regrowth and healing does not occur.

## 3. Test Methods

### 3.1. Testing Parameters

3.1.1. Several parameters will be tested and measured in order to analyze which screw and plate characteristics are most beneficial to the rigid fixation system. Dehiscence is the first parameter to be observed which would measure the separation of sternal halves on the anterior side. Splay would be measured as well, which refers to the separation on the posterior side of the sample. Screw loosening will be analyzed and shows the change in screw hole size. Lastly, plate displacement will be measured which alludes to the overall stability of the system.

### 3.2. Instron Program

3.2.1. The Instron machine will be programmed to complete 2500 cycles for each test ranging from 0-50N ( $\pm 0.4\%$ ) at force rate 33N/s (0.33Hz). We anticipate that each test will take between two and three hours.

### 3.3. Fixture Preparation

3.3.1. Prior to potting sternum samples with putty, the fixtures need to be properly prepared. Be sure that residual putty from prior test is removed from all fixture walls and guiding systems. This ensures that proper alignment is reached using the reference system. Next, line the inside of the fixture walls with one layer of scotch tape. This allows the putty to be removed from the fixtures post-test. Ensure that all screws are tightened before potting.

### 3.4. Polyurethane Sternum Sample Preparation

3.4.1. Prior to testing each plated sample, several things need to be done to the sample to get proper adhesion to the putty. First, the portions of the sample that will be potted within the putty are scoured with a scalpel. This allows the putty to grip the sample

better and reduce the occurrence of sample and putty separation during testing. After scouring, each sample is thoroughly vacuumed to remove and small polyurethane particles that may reduce putty/sample adhesion.

### 3.5. Cadaveric Sternum Sample Preparation

3.5.1. Before handling the tissue, be sure to wear all available lab garments such as lab coat, gloves, goggles, and facial masks. Next tissue can be removed from the refrigerator. After laying down a surgical drape on the work surface, wrap the sternum area of your sample with PBS soaked gauze. This moisturizes the sample while it is being worked with. Next a scalpel is used to remove the periosteum from the rib sections of the sternum samples along with any other soft tissue remnants that are attached to this part. Now super glue is applied to the rib sections of the sample. Sometimes two coats of super glue are used. This seals in any moisture from the sample so that bone potting can continue successfully. Once the superglue has dried, potting procedures can continue as discussed in the initial protocol. Once sample is potted, be sure to apply a little more PBS to the sample before testing commences.

### 3.6. Bone Potting and Sample Alignment

3.6.1. Bone tissue samples will be potted into custom testing fixtures using All-purpose putty. Each sample will be fitted into the guiding rail system so that the cuts between rib pairs are fitted against the guiding rails and so that the anterior and posterior sides of the sample are held by the threaded rods. The samples will be situated so that the anatomical rib is in the upper testing fixture. While fitting the sample into the guiding fixture, the sternotomy cut will be aligned so that it is parallel to the top edge of the fixture. Each sample will be potted two centimeters away from the sternotomy cut. This will be achieved by first drawing reference lines on the samples two centimeters from the median cut to make alignment easier. Putty components will then be mixed and poured into the fixture well (one and a half scoops per fixture). Then the aligned sample in the guiding rails and rods will be placed on top of the filled fixture. Once the sample is inserted into the putty, putty will be pushed towards the sample so meet potting line as well as ensure proper adhesion. Approximately thirty minutes will elapse as the putty hardens. Once the putty material has dried and hardened, the referencing system will be removed from the testing fixture. The fixture containing the sample will then be inverted and gripped in the Instron machine. The bottom fixture will be inserted and aligned underneath the second half of the sample in the same manner as described above. The same protocol will be followed for putty mixing. Once putty has been added to the bottom fixture, the top fixture/potted sample will be moved down by the Instron by pressing the “jog down” button. This will be lowered until the potting line is flush with the edge of the fixture and putty line. Again, putty will be pushed towards the sample to ensure adhesion occurs. Allow thirty minutes to

elapse for the putty to harden. After testing, the fixtures will be removed from the Instron and separated from the putty/sternum sample in order to reuse the fixtures. The screws that hold the fixture box together will be removed and a screwdriver will be used to separate the PMMA/sternum sample from the metal of the fixture.

### 3.7. Instron Mounting

3.7.1. To align the fixtures and samples into the Instron Machine will be quite simple. The T-bar design of our grips will enable quick and easy mounting and dismounting the fixtures from the machine. To mount the fixtures, the bottom fixture will first be placed between the clamp grips on the Instron so that the T shape of the grips is facing forward. The Instron clamps will then be slowly tightened onto the fixture so that the clamps rest above the bottom t-bar. The same protocol will be followed for gripping the top fixture. The Instron clamps will close around the stem of the t-bar on the top fixture securing it in place for testing. Once the sample is fully mounted in the Instron grips, small c-clamps are applied to each side of each fixture to hold putty and fixture together during testing.

### 3.8. Beginning Cyclic Test

3.8.1. To begin cyclic testing, choose the appropriate method in the Bluehill software. Name your sample something appropriate. Zero the load and extension in the program. Press start to commence testing. Be sure to export data at the end of the test.

### 3.9. Pre-test Measurements

3.9.1. Several measurements need to be acquired prior to testing any given sample. The angle of the sternotomy cut to the fixation plate must be recorded. Plate orientation in relation to the location of the ribs will also be recorded. The separation of the sternotomy halves will be recorded on the anterior and posterior sides at the superior and inferior edge of the sample. A ratio will be recorded comparing the length of the rib pair to the width of the ribs. Bone plate separation will be recorded at each screw site. Whether the plate was contoured to the sample will be documented. The “looseness/strength” of the system will be recorded prior to testing. A 1-5 scale as described below will be used objectively to determine overall sturdiness of each sample. Several pictures of each sample will be taken. Lastly, any other notable information about each sample will be recorded for future reference and comparison.

3.9.2. These measurements will be taken in a variety of ways. The angle between the sternotomy cut and plate will be made using a protractor. The protractor will be aligned with the top edge of the plate and measured at where the sternotomy cut lies. Plate orientation in relation to the ribs will be documented through digital photographs and measured with calipers from the inferior and superior edges of each side of the protruding rib to the median of the fixation plate. Initial separation of the sternal halves will be measured by taking digital pictures of both the anterior

and posterior sides of the sample. These images will be uploaded and analyzed using Image J software. Reference points on the samples will be measured with the software to gain an initial separation measurement. These reference points will be a series of dots, one on either side of the cut on the inferior and superior edges of both the anterior and posterior sides of the sample. A metric ruler will sit alongside the sample in each picture in order for the software to convert pixels to millimeters. Rib pair length versus rib width will be measured with calipers and will then be calculated into a ratio. Initial bone plate separation at each screw site will also be measured with calipers. The overall strength of the system will be decided upon by the observations of the team members. A rating of one would mean that when picked up or lightly shaken that elements of the fixation system would fall off of the sternal samples. To be given a rating of a five, the sample would be extremely rigid and strong even when shaken or lightly pulled on or twisted. The other ratings fall respectively between these two extremes. These observations will be reached at the discretion of the team members.

### 3.10. During-test Measurements

3.10.1. No data will be recorded during cyclic fatigue testing.

### 3.11. Post-test Measurements

3.11.1. Multiple measurements will be gathered following each test. Screw loosening will be measured. Separation on the anterior and posterior sides at both the superior and inferior edge will be measured. Bone plate displacement will be recorded at each screw site. The overall looseness/strength of the system will be analyzed using the 1-5 rating system. Longitudinal displacement will be recorded. Lastly, any other notable observations will be recorded.

3.11.2. Screw loosening will be measured by measuring the resultant screw hole size using calipers and comparing this value to the major diameter of the screws used. Resulting separation of the sternal halves will be measured by taking digital pictures of each sample. These images will be uploaded and analyzed using Image J software. The reference points on the samples made prior to testing will be measured with the software to gain a final separation measurement which will be compared to the initial separation measurement. The strength of the system will be decided upon by the observations of the team members using the 1-5 rating system.

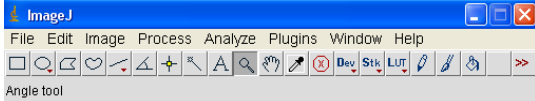
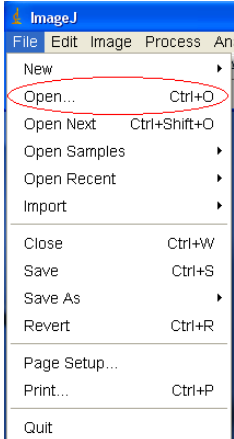
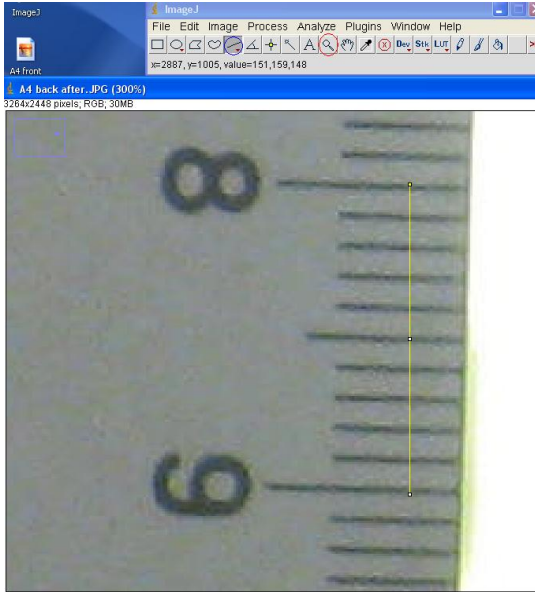
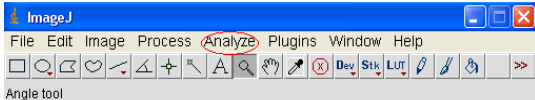

APPENDIX R - IMAGEJ PROCESSING PROCEDURE

| Procedure  | Photo  |
|--|--|
| <p>Load the ImageJ program (Can be downloaded at <a href="http://rsbweb.nih.gov/ij/">http://rsbweb.nih.gov/ij/</a>)</p>  |    |
| <p>ImageJ can upload JPEG, TIFF, GIF, PNG, and BMP formats using the Open function in the File tab (circled in red).</p>   |   |
| <p>Utilizing the zoom function on the tool bar (circled in red), zoom in on the calibration ruler and sketch a line using the drawing tools (circled in blue).</p> |  |
| <p>Once the line is drawn, use the “Set Scale...” function under the Analyze tab</p>   |  |

The distance in pixels from the line is already calculated. Input the known distance of the line drawn.

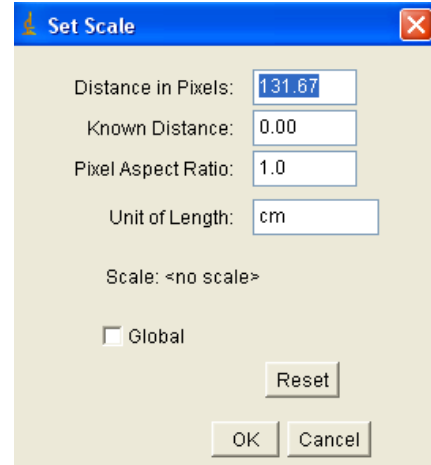

Under the Analyze tab, select “Set Measurements” to specify the desired measurements for the image. In this case centroid and area is needed for this specific measurement.

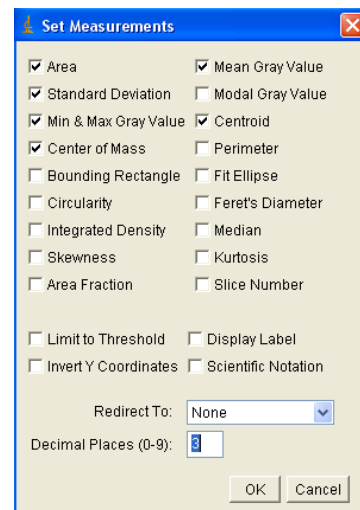

Zoom into the sample to a desired location where the dots are visible. Use the elliptical function (circled in red) to encircle the dot.

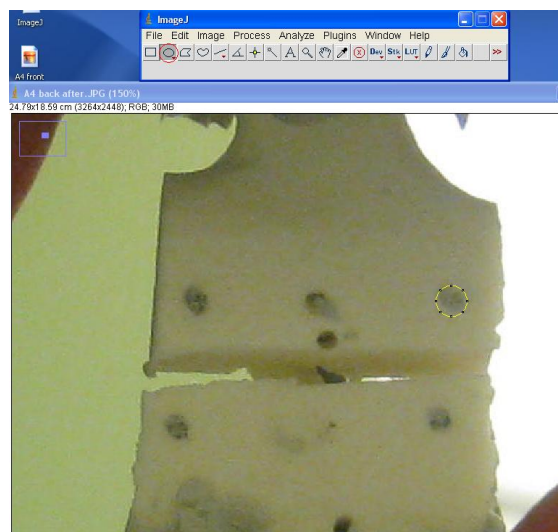

Under the Analyze tab, select the measure option. A window should pop up with all desired measurements selected in the “Set Measurements” option. The X and Y values are the centroid values within the ellipse.

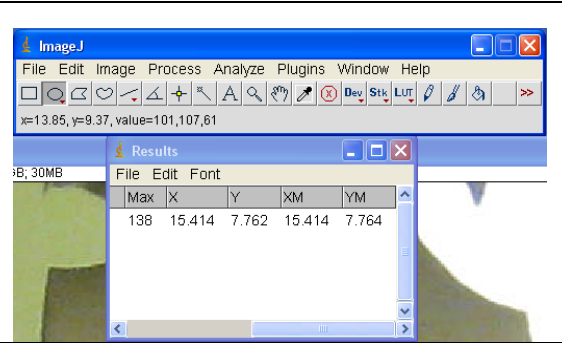

In order to document the values one can save the results under the file tab in results.

Under the Analyze tab, highlight the Tools subfolder and select the ROI manager.

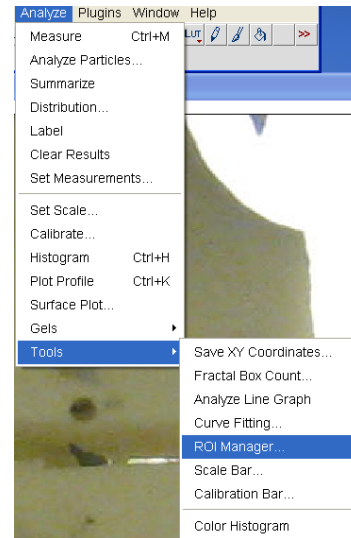

Using the ROI Manager, select the Add button to the drawn circle or line. Select the More button to add any visual indication of the measurement such as the draw feature. When saved it will document the measurements in a RAR file where it can be loaded at any time.

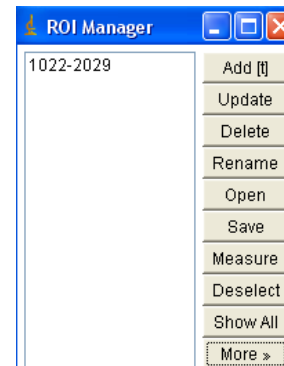

Draw another elliptical encircling the rest of the dots. Measure and record all the values using the Measure tool and the ROI manager.

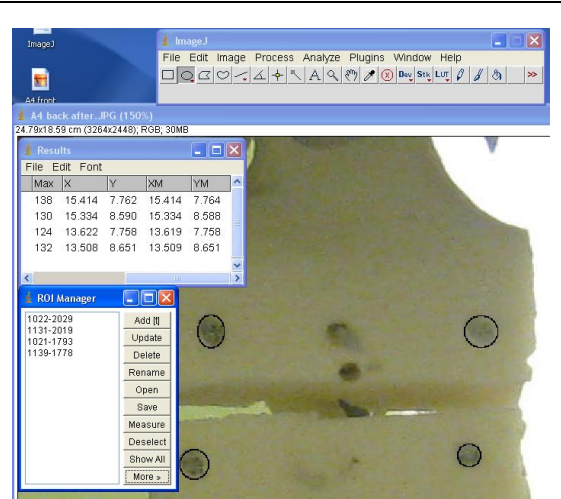

Using the result values of the centroid, select the line tool and carefully hover over the image. In the bottom left corner of the ImageJ program should reveal the X and Y coordinates of where the line tool is pointing to (highlighted in red).

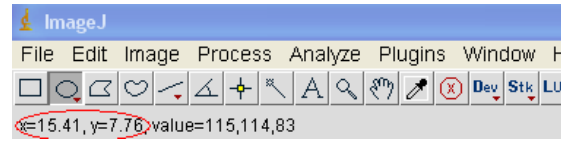

Match the centroids with each other and use the measuring tool to calculate the length. Use the ROI manager to add, draw and save the image.

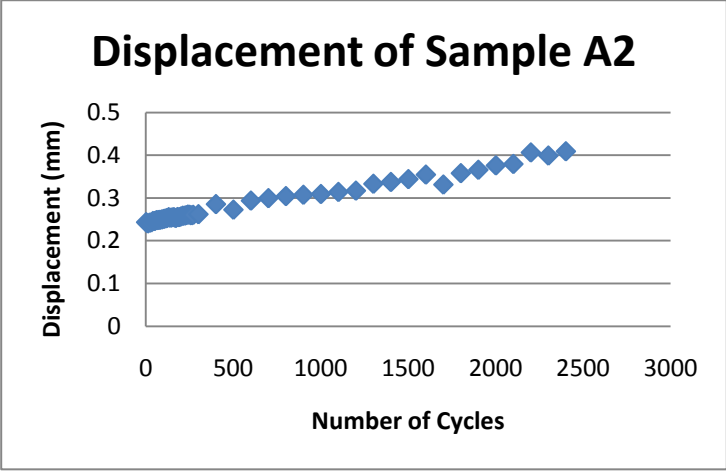
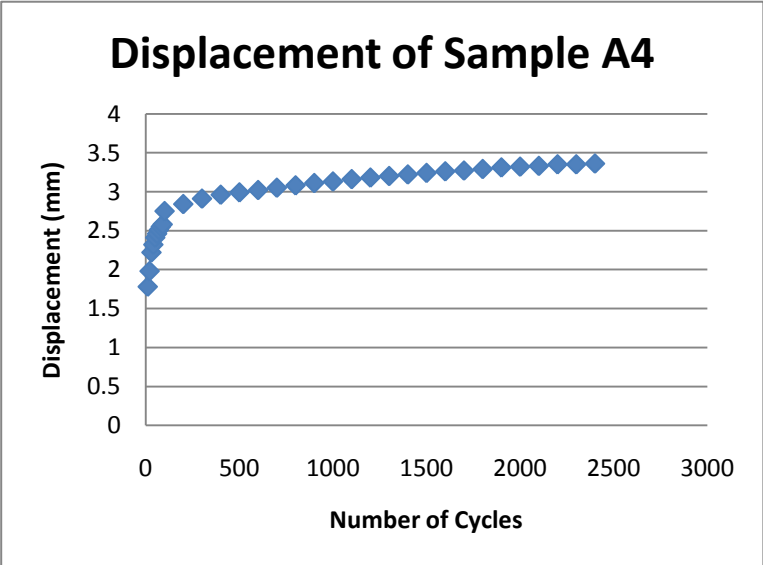

**APPENDIX S – FULL LIST OF LOAD CELL DATA ANALYSIS**

| Sample | Graph   | Hardware                    | Total bone separation [mm] |
|--------|---|-----------------------------|----------------------------|
| A2     |  <p><b>Displacement of Sample A2</b></p> <p>The graph shows displacement in millimeters on the y-axis (0 to 0.5) against the number of cycles on the x-axis (0 to 3000). The data points, represented by blue diamonds, start at approximately 0.25 mm at 0 cycles and gradually increase to about 0.4 mm at 2500 cycles.</p>   | Unicortical;<br>2.3mm screw | 0.17                       |
| A4     |  <p><b>Displacement of Sample A4</b></p> <p>The graph shows displacement in millimeters on the y-axis (0 to 4) against the number of cycles on the x-axis (0 to 3000). The data points, represented by blue diamonds, start at approximately 1.8 mm at 0 cycles, rise sharply to about 3.0 mm by 250 cycles, and then continue to rise slowly to approximately 3.4 mm at 2500 cycles.</p> | Unicortical;<br>2.3mm screw | 1.59                       |
| A5     |   | Unicortical;<br>2.3mm screw | 3.07                       |

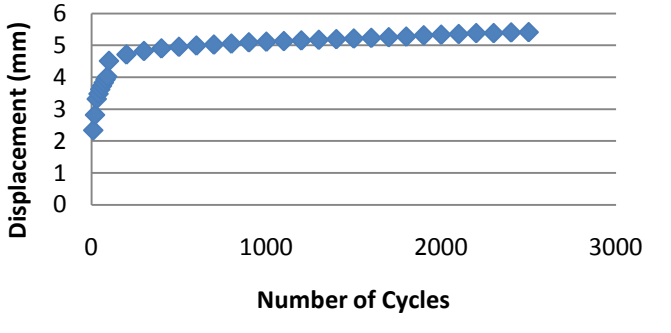
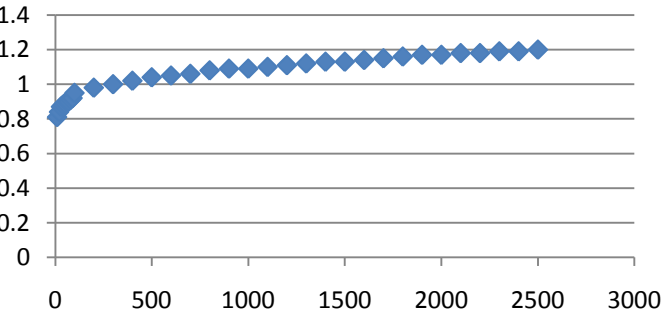
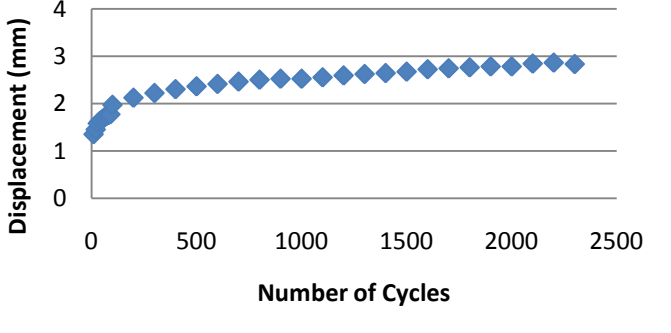
|    |  |            |      |
|----|--|------------|------|
|    | <p style="text-align: center;"><b>Displacement of Sample A5</b></p>    |            |      |
| B3 | <p style="text-align: center;"><b>Displacement of sample B3</b></p>   | Bicortical | 0.39 |
| B4 | <p style="text-align: center;"><b>Displacement of Sample B4</b></p>  | Bicortical | 1.52 |

| B5               | <h3 style="text-align: center;">Displacement of Sample B5</h3> <table border="1"> <caption>Approximate data for Sample B5</caption> <thead> <tr> <th># of cycles</th> <th>Distance [mm]</th> </tr> </thead> <tbody> <tr><td>0</td><td>0.7</td></tr> <tr><td>500</td><td>1.2</td></tr> <tr><td>1000</td><td>1.5</td></tr> <tr><td>1500</td><td>1.7</td></tr> <tr><td>2000</td><td>1.9</td></tr> <tr><td>2500</td><td>2.0</td></tr> </tbody> </table>          | # of cycles      | Distance [mm]     | 0 | 0.7 | 500 | 1.2 | 1000 | 1.5 | 1500 | 1.7 | 2000 | 1.9 | 2500 | 2.0 | bicortical  | 1.26 |
|------------------|--|------------------|-------------------|---|-----|-----|-----|------|-----|------|-----|------|-----|------|-----|-------------|------|
| # of cycles      | Distance [mm]  |                  |                   |   |     |     |     |      |     |      |     |      |     |      |     |             |      |
| 0                | 0.7  |                  |                   |   |     |     |     |      |     |      |     |      |     |      |     |             |      |
| 500              | 1.2  |                  |                   |   |     |     |     |      |     |      |     |      |     |      |     |             |      |
| 1000             | 1.5  |                  |                   |   |     |     |     |      |     |      |     |      |     |      |     |             |      |
| 1500             | 1.7  |                  |                   |   |     |     |     |      |     |      |     |      |     |      |     |             |      |
| 2000             | 1.9  |                  |                   |   |     |     |     |      |     |      |     |      |     |      |     |             |      |
| 2500             | 2.0  |                  |                   |   |     |     |     |      |     |      |     |      |     |      |     |             |      |
| C1               | <h3 style="text-align: center;">Displacement of Sample C1</h3> <table border="1"> <caption>Approximate data for Sample C1</caption> <thead> <tr> <th>Number of Cycles</th> <th>Displacement (mm)</th> </tr> </thead> <tbody> <tr><td>0</td><td>2.2</td></tr> <tr><td>500</td><td>2.8</td></tr> <tr><td>1000</td><td>3.1</td></tr> <tr><td>1500</td><td>3.3</td></tr> <tr><td>2000</td><td>3.5</td></tr> <tr><td>2500</td><td>3.6</td></tr> </tbody> </table> | Number of Cycles | Displacement (mm) | 0 | 2.2 | 500 | 2.8 | 1000 | 3.1 | 1500 | 3.3 | 2000 | 3.5 | 2500 | 3.6 | 2.0mm screw | 1.34 |
| Number of Cycles | Displacement (mm)  |                  |                   |   |     |     |     |      |     |      |     |      |     |      |     |             |      |
| 0                | 2.2  |                  |                   |   |     |     |     |      |     |      |     |      |     |      |     |             |      |
| 500              | 2.8  |                  |                   |   |     |     |     |      |     |      |     |      |     |      |     |             |      |
| 1000             | 3.1  |                  |                   |   |     |     |     |      |     |      |     |      |     |      |     |             |      |
| 1500             | 3.3  |                  |                   |   |     |     |     |      |     |      |     |      |     |      |     |             |      |
| 2000             | 3.5  |                  |                   |   |     |     |     |      |     |      |     |      |     |      |     |             |      |
| 2500             | 3.6  |                  |                   |   |     |     |     |      |     |      |     |      |     |      |     |             |      |
| C3               | <h3 style="text-align: center;">Displacement of Sample C3</h3> <table border="1"> <caption>Approximate data for Sample C3</caption> <thead> <tr> <th>Number of Cycles</th> <th>Displacement (mm)</th> </tr> </thead> <tbody> <tr><td>0</td><td>2.5</td></tr> <tr><td>500</td><td>3.4</td></tr> <tr><td>1000</td><td>3.6</td></tr> <tr><td>1500</td><td>3.7</td></tr> <tr><td>2000</td><td>3.8</td></tr> <tr><td>2500</td><td>3.9</td></tr> </tbody> </table> | Number of Cycles | Displacement (mm) | 0 | 2.5 | 500 | 3.4 | 1000 | 3.6 | 1500 | 3.7 | 2000 | 3.8 | 2500 | 3.9 | 2.0mm screw | 1.32 |
| Number of Cycles | Displacement (mm)  |                  |                   |   |     |     |     |      |     |      |     |      |     |      |     |             |      |
| 0                | 2.5  |                  |                   |   |     |     |     |      |     |      |     |      |     |      |     |             |      |
| 500              | 3.4  |                  |                   |   |     |     |     |      |     |      |     |      |     |      |     |             |      |
| 1000             | 3.6  |                  |                   |   |     |     |     |      |     |      |     |      |     |      |     |             |      |
| 1500             | 3.7  |                  |                   |   |     |     |     |      |     |      |     |      |     |      |     |             |      |
| 2000             | 3.8  |                  |                   |   |     |     |     |      |     |      |     |      |     |      |     |             |      |
| 2500             | 3.9  |                  |                   |   |     |     |     |      |     |      |     |      |     |      |     |             |      |

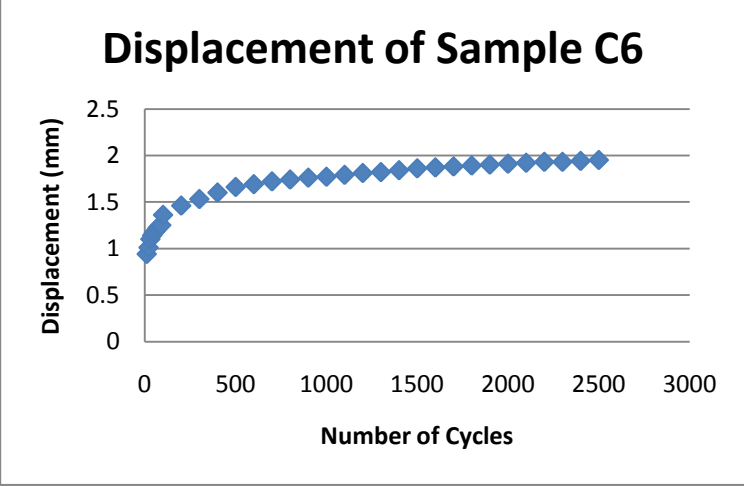
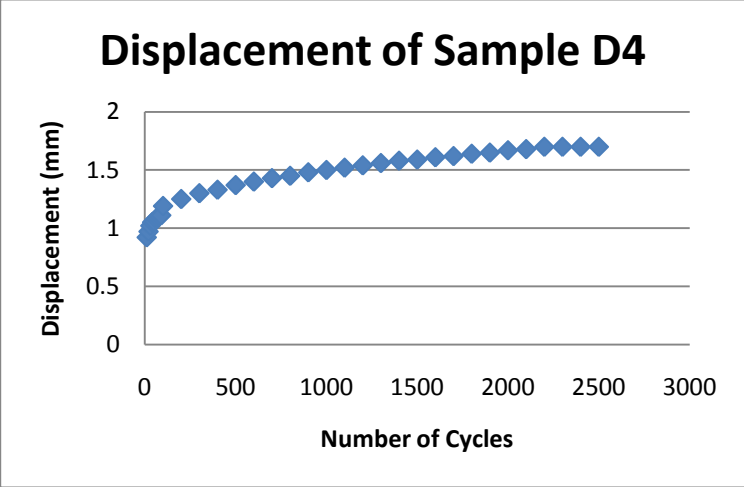
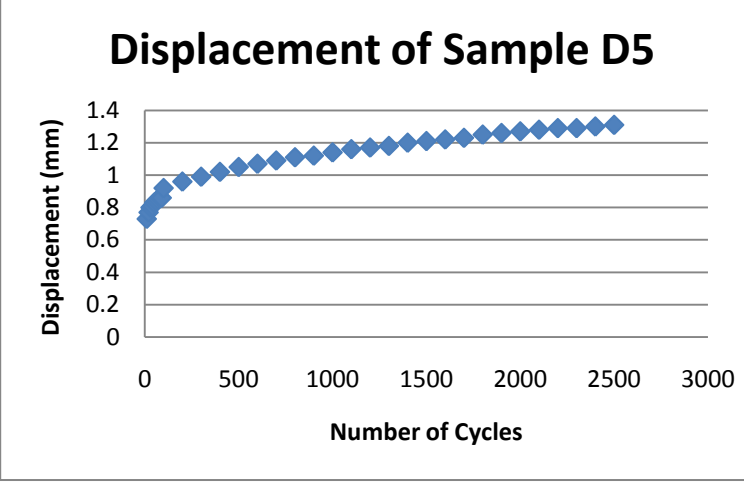
| C6               | <p style="text-align: center;"><b>Displacement of Sample C6</b></p>  <p>The graph for Sample C6 shows a curve that starts at (0, 0.9) and rises to a plateau of approximately 1.9 mm after 1000 cycles. The data points are as follows:</p> <table border="1"> <thead> <tr> <th>Number of Cycles</th> <th>Displacement (mm)</th> </tr> </thead> <tbody> <tr><td>0</td><td>0.9</td></tr> <tr><td>100</td><td>1.1</td></tr> <tr><td>200</td><td>1.2</td></tr> <tr><td>300</td><td>1.3</td></tr> <tr><td>400</td><td>1.4</td></tr> <tr><td>500</td><td>1.5</td></tr> <tr><td>600</td><td>1.6</td></tr> <tr><td>700</td><td>1.65</td></tr> <tr><td>800</td><td>1.7</td></tr> <tr><td>900</td><td>1.75</td></tr> <tr><td>1000</td><td>1.8</td></tr> <tr><td>1100</td><td>1.8</td></tr> <tr><td>1200</td><td>1.8</td></tr> <tr><td>1300</td><td>1.8</td></tr> <tr><td>1400</td><td>1.8</td></tr> <tr><td>1500</td><td>1.8</td></tr> <tr><td>1600</td><td>1.8</td></tr> <tr><td>1700</td><td>1.8</td></tr> <tr><td>1800</td><td>1.8</td></tr> <tr><td>1900</td><td>1.8</td></tr> <tr><td>2000</td><td>1.8</td></tr> <tr><td>2100</td><td>1.8</td></tr> <tr><td>2200</td><td>1.8</td></tr> <tr><td>2300</td><td>1.8</td></tr> <tr><td>2400</td><td>1.8</td></tr> <tr><td>2500</td><td>1.8</td></tr> </tbody> </table>                    | Number of Cycles | Displacement (mm) | 0 | 0.9 | 100 | 1.1 | 200 | 1.2  | 300 | 1.3 | 400 | 1.4  | 500 | 1.5  | 600 | 1.6  | 700 | 1.65 | 800 | 1.7  | 900 | 1.75 | 1000 | 1.8  | 1100 | 1.8  | 1200 | 1.8  | 1300 | 1.8  | 1400 | 1.8  | 1500 | 1.8  | 1600 | 1.8  | 1700 | 1.8  | 1800 | 1.8  | 1900 | 1.8  | 2000 | 1.8  | 2100 | 1.8  | 2200 | 1.8  | 2300 | 1.8  | 2400 | 1.8  | 2500 | 1.8  | Unicortical;<br>2.3mm screw | 1.01 |
|------------------|--|------------------|-------------------|---|-----|-----|-----|-----|------|-----|-----|-----|------|-----|------|-----|------|-----|------|-----|------|-----|------|------|------|------|------|------|------|------|------|------|------|------|------|------|------|------|------|------|------|------|------|------|------|------|------|------|------|------|------|------|------|------|------|-----------------------------|------|
| Number of Cycles | Displacement (mm)  |                  |                   |   |     |     |     |     |      |     |     |     |      |     |      |     |      |     |      |     |      |     |      |      |      |      |      |      |      |      |      |      |      |      |      |      |      |      |      |      |      |      |      |      |      |      |      |      |      |      |      |      |      |      |      |                             |      |
| 0                | 0.9  |                  |                   |   |     |     |     |     |      |     |     |     |      |     |      |     |      |     |      |     |      |     |      |      |      |      |      |      |      |      |      |      |      |      |      |      |      |      |      |      |      |      |      |      |      |      |      |      |      |      |      |      |      |      |      |                             |      |
| 100              | 1.1  |                  |                   |   |     |     |     |     |      |     |     |     |      |     |      |     |      |     |      |     |      |     |      |      |      |      |      |      |      |      |      |      |      |      |      |      |      |      |      |      |      |      |      |      |      |      |      |      |      |      |      |      |      |      |      |                             |      |
| 200              | 1.2  |                  |                   |   |     |     |     |     |      |     |     |     |      |     |      |     |      |     |      |     |      |     |      |      |      |      |      |      |      |      |      |      |      |      |      |      |      |      |      |      |      |      |      |      |      |      |      |      |      |      |      |      |      |      |      |                             |      |
| 300              | 1.3  |                  |                   |   |     |     |     |     |      |     |     |     |      |     |      |     |      |     |      |     |      |     |      |      |      |      |      |      |      |      |      |      |      |      |      |      |      |      |      |      |      |      |      |      |      |      |      |      |      |      |      |      |      |      |      |                             |      |
| 400              | 1.4  |                  |                   |   |     |     |     |     |      |     |     |     |      |     |      |     |      |     |      |     |      |     |      |      |      |      |      |      |      |      |      |      |      |      |      |      |      |      |      |      |      |      |      |      |      |      |      |      |      |      |      |      |      |      |      |                             |      |
| 500              | 1.5  |                  |                   |   |     |     |     |     |      |     |     |     |      |     |      |     |      |     |      |     |      |     |      |      |      |      |      |      |      |      |      |      |      |      |      |      |      |      |      |      |      |      |      |      |      |      |      |      |      |      |      |      |      |      |      |                             |      |
| 600              | 1.6  |                  |                   |   |     |     |     |     |      |     |     |     |      |     |      |     |      |     |      |     |      |     |      |      |      |      |      |      |      |      |      |      |      |      |      |      |      |      |      |      |      |      |      |      |      |      |      |      |      |      |      |      |      |      |      |                             |      |
| 700              | 1.65   |                  |                   |   |     |     |     |     |      |     |     |     |      |     |      |     |      |     |      |     |      |     |      |      |      |      |      |      |      |      |      |      |      |      |      |      |      |      |      |      |      |      |      |      |      |      |      |      |      |      |      |      |      |      |      |                             |      |
| 800              | 1.7  |                  |                   |   |     |     |     |     |      |     |     |     |      |     |      |     |      |     |      |     |      |     |      |      |      |      |      |      |      |      |      |      |      |      |      |      |      |      |      |      |      |      |      |      |      |      |      |      |      |      |      |      |      |      |      |                             |      |
| 900              | 1.75   |                  |                   |   |     |     |     |     |      |     |     |     |      |     |      |     |      |     |      |     |      |     |      |      |      |      |      |      |      |      |      |      |      |      |      |      |      |      |      |      |      |      |      |      |      |      |      |      |      |      |      |      |      |      |      |                             |      |
| 1000             | 1.8  |                  |                   |   |     |     |     |     |      |     |     |     |      |     |      |     |      |     |      |     |      |     |      |      |      |      |      |      |      |      |      |      |      |      |      |      |      |      |      |      |      |      |      |      |      |      |      |      |      |      |      |      |      |      |      |                             |      |
| 1100             | 1.8  |                  |                   |   |     |     |     |     |      |     |     |     |      |     |      |     |      |     |      |     |      |     |      |      |      |      |      |      |      |      |      |      |      |      |      |      |      |      |      |      |      |      |      |      |      |      |      |      |      |      |      |      |      |      |      |                             |      |
| 1200             | 1.8  |                  |                   |   |     |     |     |     |      |     |     |     |      |     |      |     |      |     |      |     |      |     |      |      |      |      |      |      |      |      |      |      |      |      |      |      |      |      |      |      |      |      |      |      |      |      |      |      |      |      |      |      |      |      |      |                             |      |
| 1300             | 1.8  |                  |                   |   |     |     |     |     |      |     |     |     |      |     |      |     |      |     |      |     |      |     |      |      |      |      |      |      |      |      |      |      |      |      |      |      |      |      |      |      |      |      |      |      |      |      |      |      |      |      |      |      |      |      |      |                             |      |
| 1400             | 1.8  |                  |                   |   |     |     |     |     |      |     |     |     |      |     |      |     |      |     |      |     |      |     |      |      |      |      |      |      |      |      |      |      |      |      |      |      |      |      |      |      |      |      |      |      |      |      |      |      |      |      |      |      |      |      |      |                             |      |
| 1500             | 1.8  |                  |                   |   |     |     |     |     |      |     |     |     |      |     |      |     |      |     |      |     |      |     |      |      |      |      |      |      |      |      |      |      |      |      |      |      |      |      |      |      |      |      |      |      |      |      |      |      |      |      |      |      |      |      |      |                             |      |
| 1600             | 1.8  |                  |                   |   |     |     |     |     |      |     |     |     |      |     |      |     |      |     |      |     |      |     |      |      |      |      |      |      |      |      |      |      |      |      |      |      |      |      |      |      |      |      |      |      |      |      |      |      |      |      |      |      |      |      |      |                             |      |
| 1700             | 1.8  |                  |                   |   |     |     |     |     |      |     |     |     |      |     |      |     |      |     |      |     |      |     |      |      |      |      |      |      |      |      |      |      |      |      |      |      |      |      |      |      |      |      |      |      |      |      |      |      |      |      |      |      |      |      |      |                             |      |
| 1800             | 1.8  |                  |                   |   |     |     |     |     |      |     |     |     |      |     |      |     |      |     |      |     |      |     |      |      |      |      |      |      |      |      |      |      |      |      |      |      |      |      |      |      |      |      |      |      |      |      |      |      |      |      |      |      |      |      |      |                             |      |
| 1900             | 1.8  |                  |                   |   |     |     |     |     |      |     |     |     |      |     |      |     |      |     |      |     |      |     |      |      |      |      |      |      |      |      |      |      |      |      |      |      |      |      |      |      |      |      |      |      |      |      |      |      |      |      |      |      |      |      |      |                             |      |
| 2000             | 1.8  |                  |                   |   |     |     |     |     |      |     |     |     |      |     |      |     |      |     |      |     |      |     |      |      |      |      |      |      |      |      |      |      |      |      |      |      |      |      |      |      |      |      |      |      |      |      |      |      |      |      |      |      |      |      |      |                             |      |
| 2100             | 1.8  |                  |                   |   |     |     |     |     |      |     |     |     |      |     |      |     |      |     |      |     |      |     |      |      |      |      |      |      |      |      |      |      |      |      |      |      |      |      |      |      |      |      |      |      |      |      |      |      |      |      |      |      |      |      |      |                             |      |
| 2200             | 1.8  |                  |                   |   |     |     |     |     |      |     |     |     |      |     |      |     |      |     |      |     |      |     |      |      |      |      |      |      |      |      |      |      |      |      |      |      |      |      |      |      |      |      |      |      |      |      |      |      |      |      |      |      |      |      |      |                             |      |
| 2300             | 1.8  |                  |                   |   |     |     |     |     |      |     |     |     |      |     |      |     |      |     |      |     |      |     |      |      |      |      |      |      |      |      |      |      |      |      |      |      |      |      |      |      |      |      |      |      |      |      |      |      |      |      |      |      |      |      |      |                             |      |
| 2400             | 1.8  |                  |                   |   |     |     |     |     |      |     |     |     |      |     |      |     |      |     |      |     |      |     |      |      |      |      |      |      |      |      |      |      |      |      |      |      |      |      |      |      |      |      |      |      |      |      |      |      |      |      |      |      |      |      |      |                             |      |
| 2500             | 1.8  |                  |                   |   |     |     |     |     |      |     |     |     |      |     |      |     |      |     |      |     |      |     |      |      |      |      |      |      |      |      |      |      |      |      |      |      |      |      |      |      |      |      |      |      |      |      |      |      |      |      |      |      |      |      |      |                             |      |
| D4               | <p style="text-align: center;"><b>Displacement of Sample D4</b></p>  <p>The graph for Sample D4 shows a curve that starts at (0, 0.9) and rises to a plateau of approximately 1.7 mm after 1000 cycles. The data points are as follows:</p> <table border="1"> <thead> <tr> <th>Number of Cycles</th> <th>Displacement (mm)</th> </tr> </thead> <tbody> <tr><td>0</td><td>0.9</td></tr> <tr><td>100</td><td>1.1</td></tr> <tr><td>200</td><td>1.2</td></tr> <tr><td>300</td><td>1.3</td></tr> <tr><td>400</td><td>1.35</td></tr> <tr><td>500</td><td>1.4</td></tr> <tr><td>600</td><td>1.45</td></tr> <tr><td>700</td><td>1.48</td></tr> <tr><td>800</td><td>1.5</td></tr> <tr><td>900</td><td>1.52</td></tr> <tr><td>1000</td><td>1.55</td></tr> <tr><td>1100</td><td>1.55</td></tr> <tr><td>1200</td><td>1.55</td></tr> <tr><td>1300</td><td>1.55</td></tr> <tr><td>1400</td><td>1.55</td></tr> <tr><td>1500</td><td>1.55</td></tr> <tr><td>1600</td><td>1.55</td></tr> <tr><td>1700</td><td>1.55</td></tr> <tr><td>1800</td><td>1.55</td></tr> <tr><td>1900</td><td>1.55</td></tr> <tr><td>2000</td><td>1.55</td></tr> <tr><td>2100</td><td>1.55</td></tr> <tr><td>2200</td><td>1.55</td></tr> <tr><td>2300</td><td>1.55</td></tr> <tr><td>2400</td><td>1.55</td></tr> <tr><td>2500</td><td>1.55</td></tr> </tbody> </table> | Number of Cycles | Displacement (mm) | 0 | 0.9 | 100 | 1.1 | 200 | 1.2  | 300 | 1.3 | 400 | 1.35 | 500 | 1.4  | 600 | 1.45 | 700 | 1.48 | 800 | 1.5  | 900 | 1.52 | 1000 | 1.55 | 1100 | 1.55 | 1200 | 1.55 | 1300 | 1.55 | 1400 | 1.55 | 1500 | 1.55 | 1600 | 1.55 | 1700 | 1.55 | 1800 | 1.55 | 1900 | 1.55 | 2000 | 1.55 | 2100 | 1.55 | 2200 | 1.55 | 2300 | 1.55 | 2400 | 1.55 | 2500 | 1.55 | Locking                     | 0.78 |
| Number of Cycles | Displacement (mm)  |                  |                   |   |     |     |     |     |      |     |     |     |      |     |      |     |      |     |      |     |      |     |      |      |      |      |      |      |      |      |      |      |      |      |      |      |      |      |      |      |      |      |      |      |      |      |      |      |      |      |      |      |      |      |      |                             |      |
| 0                | 0.9  |                  |                   |   |     |     |     |     |      |     |     |     |      |     |      |     |      |     |      |     |      |     |      |      |      |      |      |      |      |      |      |      |      |      |      |      |      |      |      |      |      |      |      |      |      |      |      |      |      |      |      |      |      |      |      |                             |      |
| 100              | 1.1  |                  |                   |   |     |     |     |     |      |     |     |     |      |     |      |     |      |     |      |     |      |     |      |      |      |      |      |      |      |      |      |      |      |      |      |      |      |      |      |      |      |      |      |      |      |      |      |      |      |      |      |      |      |      |      |                             |      |
| 200              | 1.2  |                  |                   |   |     |     |     |     |      |     |     |     |      |     |      |     |      |     |      |     |      |     |      |      |      |      |      |      |      |      |      |      |      |      |      |      |      |      |      |      |      |      |      |      |      |      |      |      |      |      |      |      |      |      |      |                             |      |
| 300              | 1.3  |                  |                   |   |     |     |     |     |      |     |     |     |      |     |      |     |      |     |      |     |      |     |      |      |      |      |      |      |      |      |      |      |      |      |      |      |      |      |      |      |      |      |      |      |      |      |      |      |      |      |      |      |      |      |      |                             |      |
| 400              | 1.35   |                  |                   |   |     |     |     |     |      |     |     |     |      |     |      |     |      |     |      |     |      |     |      |      |      |      |      |      |      |      |      |      |      |      |      |      |      |      |      |      |      |      |      |      |      |      |      |      |      |      |      |      |      |      |      |                             |      |
| 500              | 1.4  |                  |                   |   |     |     |     |     |      |     |     |     |      |     |      |     |      |     |      |     |      |     |      |      |      |      |      |      |      |      |      |      |      |      |      |      |      |      |      |      |      |      |      |      |      |      |      |      |      |      |      |      |      |      |      |                             |      |
| 600              | 1.45   |                  |                   |   |     |     |     |     |      |     |     |     |      |     |      |     |      |     |      |     |      |     |      |      |      |      |      |      |      |      |      |      |      |      |      |      |      |      |      |      |      |      |      |      |      |      |      |      |      |      |      |      |      |      |      |                             |      |
| 700              | 1.48   |                  |                   |   |     |     |     |     |      |     |     |     |      |     |      |     |      |     |      |     |      |     |      |      |      |      |      |      |      |      |      |      |      |      |      |      |      |      |      |      |      |      |      |      |      |      |      |      |      |      |      |      |      |      |      |                             |      |
| 800              | 1.5  |                  |                   |   |     |     |     |     |      |     |     |     |      |     |      |     |      |     |      |     |      |     |      |      |      |      |      |      |      |      |      |      |      |      |      |      |      |      |      |      |      |      |      |      |      |      |      |      |      |      |      |      |      |      |      |                             |      |
| 900              | 1.52   |                  |                   |   |     |     |     |     |      |     |     |     |      |     |      |     |      |     |      |     |      |     |      |      |      |      |      |      |      |      |      |      |      |      |      |      |      |      |      |      |      |      |      |      |      |      |      |      |      |      |      |      |      |      |      |                             |      |
| 1000             | 1.55   |                  |                   |   |     |     |     |     |      |     |     |     |      |     |      |     |      |     |      |     |      |     |      |      |      |      |      |      |      |      |      |      |      |      |      |      |      |      |      |      |      |      |      |      |      |      |      |      |      |      |      |      |      |      |      |                             |      |
| 1100             | 1.55   |                  |                   |   |     |     |     |     |      |     |     |     |      |     |      |     |      |     |      |     |      |     |      |      |      |      |      |      |      |      |      |      |      |      |      |      |      |      |      |      |      |      |      |      |      |      |      |      |      |      |      |      |      |      |      |                             |      |
| 1200             | 1.55   |                  |                   |   |     |     |     |     |      |     |     |     |      |     |      |     |      |     |      |     |      |     |      |      |      |      |      |      |      |      |      |      |      |      |      |      |      |      |      |      |      |      |      |      |      |      |      |      |      |      |      |      |      |      |      |                             |      |
| 1300             | 1.55   |                  |                   |   |     |     |     |     |      |     |     |     |      |     |      |     |      |     |      |     |      |     |      |      |      |      |      |      |      |      |      |      |      |      |      |      |      |      |      |      |      |      |      |      |      |      |      |      |      |      |      |      |      |      |      |                             |      |
| 1400             | 1.55   |                  |                   |   |     |     |     |     |      |     |     |     |      |     |      |     |      |     |      |     |      |     |      |      |      |      |      |      |      |      |      |      |      |      |      |      |      |      |      |      |      |      |      |      |      |      |      |      |      |      |      |      |      |      |      |                             |      |
| 1500             | 1.55   |                  |                   |   |     |     |     |     |      |     |     |     |      |     |      |     |      |     |      |     |      |     |      |      |      |      |      |      |      |      |      |      |      |      |      |      |      |      |      |      |      |      |      |      |      |      |      |      |      |      |      |      |      |      |      |                             |      |
| 1600             | 1.55   |                  |                   |   |     |     |     |     |      |     |     |     |      |     |      |     |      |     |      |     |      |     |      |      |      |      |      |      |      |      |      |      |      |      |      |      |      |      |      |      |      |      |      |      |      |      |      |      |      |      |      |      |      |      |      |                             |      |
| 1700             | 1.55   |                  |                   |   |     |     |     |     |      |     |     |     |      |     |      |     |      |     |      |     |      |     |      |      |      |      |      |      |      |      |      |      |      |      |      |      |      |      |      |      |      |      |      |      |      |      |      |      |      |      |      |      |      |      |      |                             |      |
| 1800             | 1.55   |                  |                   |   |     |     |     |     |      |     |     |     |      |     |      |     |      |     |      |     |      |     |      |      |      |      |      |      |      |      |      |      |      |      |      |      |      |      |      |      |      |      |      |      |      |      |      |      |      |      |      |      |      |      |      |                             |      |
| 1900             | 1.55   |                  |                   |   |     |     |     |     |      |     |     |     |      |     |      |     |      |     |      |     |      |     |      |      |      |      |      |      |      |      |      |      |      |      |      |      |      |      |      |      |      |      |      |      |      |      |      |      |      |      |      |      |      |      |      |                             |      |
| 2000             | 1.55   |                  |                   |   |     |     |     |     |      |     |     |     |      |     |      |     |      |     |      |     |      |     |      |      |      |      |      |      |      |      |      |      |      |      |      |      |      |      |      |      |      |      |      |      |      |      |      |      |      |      |      |      |      |      |      |                             |      |
| 2100             | 1.55   |                  |                   |   |     |     |     |     |      |     |     |     |      |     |      |     |      |     |      |     |      |     |      |      |      |      |      |      |      |      |      |      |      |      |      |      |      |      |      |      |      |      |      |      |      |      |      |      |      |      |      |      |      |      |      |                             |      |
| 2200             | 1.55   |                  |                   |   |     |     |     |     |      |     |     |     |      |     |      |     |      |     |      |     |      |     |      |      |      |      |      |      |      |      |      |      |      |      |      |      |      |      |      |      |      |      |      |      |      |      |      |      |      |      |      |      |      |      |      |                             |      |
| 2300             | 1.55   |                  |                   |   |     |     |     |     |      |     |     |     |      |     |      |     |      |     |      |     |      |     |      |      |      |      |      |      |      |      |      |      |      |      |      |      |      |      |      |      |      |      |      |      |      |      |      |      |      |      |      |      |      |      |      |                             |      |
| 2400             | 1.55   |                  |                   |   |     |     |     |     |      |     |     |     |      |     |      |     |      |     |      |     |      |     |      |      |      |      |      |      |      |      |      |      |      |      |      |      |      |      |      |      |      |      |      |      |      |      |      |      |      |      |      |      |      |      |      |                             |      |
| 2500             | 1.55   |                  |                   |   |     |     |     |     |      |     |     |     |      |     |      |     |      |     |      |     |      |     |      |      |      |      |      |      |      |      |      |      |      |      |      |      |      |      |      |      |      |      |      |      |      |      |      |      |      |      |      |      |      |      |      |                             |      |
| D5               | <p style="text-align: center;"><b>Displacement of Sample D5</b></p>  <p>The graph for Sample D5 shows a curve that starts at (0, 0.7) and rises to a plateau of approximately 1.3 mm after 1000 cycles. The data points are as follows:</p> <table border="1"> <thead> <tr> <th>Number of Cycles</th> <th>Displacement (mm)</th> </tr> </thead> <tbody> <tr><td>0</td><td>0.7</td></tr> <tr><td>100</td><td>0.8</td></tr> <tr><td>200</td><td>0.85</td></tr> <tr><td>300</td><td>0.9</td></tr> <tr><td>400</td><td>0.95</td></tr> <tr><td>500</td><td>0.98</td></tr> <tr><td>600</td><td>1.0</td></tr> <tr><td>700</td><td>1.02</td></tr> <tr><td>800</td><td>1.05</td></tr> <tr><td>900</td><td>1.08</td></tr> <tr><td>1000</td><td>1.1</td></tr> <tr><td>1100</td><td>1.1</td></tr> <tr><td>1200</td><td>1.1</td></tr> <tr><td>1300</td><td>1.1</td></tr> <tr><td>1400</td><td>1.1</td></tr> <tr><td>1500</td><td>1.1</td></tr> <tr><td>1600</td><td>1.1</td></tr> <tr><td>1700</td><td>1.1</td></tr> <tr><td>1800</td><td>1.1</td></tr> <tr><td>1900</td><td>1.1</td></tr> <tr><td>2000</td><td>1.1</td></tr> <tr><td>2100</td><td>1.1</td></tr> <tr><td>2200</td><td>1.1</td></tr> <tr><td>2300</td><td>1.1</td></tr> <tr><td>2400</td><td>1.1</td></tr> <tr><td>2500</td><td>1.1</td></tr> </tbody> </table>              | Number of Cycles | Displacement (mm) | 0 | 0.7 | 100 | 0.8 | 200 | 0.85 | 300 | 0.9 | 400 | 0.95 | 500 | 0.98 | 600 | 1.0  | 700 | 1.02 | 800 | 1.05 | 900 | 1.08 | 1000 | 1.1  | 1100 | 1.1  | 1200 | 1.1  | 1300 | 1.1  | 1400 | 1.1  | 1500 | 1.1  | 1600 | 1.1  | 1700 | 1.1  | 1800 | 1.1  | 1900 | 1.1  | 2000 | 1.1  | 2100 | 1.1  | 2200 | 1.1  | 2300 | 1.1  | 2400 | 1.1  | 2500 | 1.1  | Locking                     | 0.58 |
| Number of Cycles | Displacement (mm)  |                  |                   |   |     |     |     |     |      |     |     |     |      |     |      |     |      |     |      |     |      |     |      |      |      |      |      |      |      |      |      |      |      |      |      |      |      |      |      |      |      |      |      |      |      |      |      |      |      |      |      |      |      |      |      |                             |      |
| 0                | 0.7  |                  |                   |   |     |     |     |     |      |     |     |     |      |     |      |     |      |     |      |     |      |     |      |      |      |      |      |      |      |      |      |      |      |      |      |      |      |      |      |      |      |      |      |      |      |      |      |      |      |      |      |      |      |      |      |                             |      |
| 100              | 0.8  |                  |                   |   |     |     |     |     |      |     |     |     |      |     |      |     |      |     |      |     |      |     |      |      |      |      |      |      |      |      |      |      |      |      |      |      |      |      |      |      |      |      |      |      |      |      |      |      |      |      |      |      |      |      |      |                             |      |
| 200              | 0.85   |                  |                   |   |     |     |     |     |      |     |     |     |      |     |      |     |      |     |      |     |      |     |      |      |      |      |      |      |      |      |      |      |      |      |      |      |      |      |      |      |      |      |      |      |      |      |      |      |      |      |      |      |      |      |      |                             |      |
| 300              | 0.9  |                  |                   |   |     |     |     |     |      |     |     |     |      |     |      |     |      |     |      |     |      |     |      |      |      |      |      |      |      |      |      |      |      |      |      |      |      |      |      |      |      |      |      |      |      |      |      |      |      |      |      |      |      |      |      |                             |      |
| 400              | 0.95   |                  |                   |   |     |     |     |     |      |     |     |     |      |     |      |     |      |     |      |     |      |     |      |      |      |      |      |      |      |      |      |      |      |      |      |      |      |      |      |      |      |      |      |      |      |      |      |      |      |      |      |      |      |      |      |                             |      |
| 500              | 0.98   |                  |                   |   |     |     |     |     |      |     |     |     |      |     |      |     |      |     |      |     |      |     |      |      |      |      |      |      |      |      |      |      |      |      |      |      |      |      |      |      |      |      |      |      |      |      |      |      |      |      |      |      |      |      |      |                             |      |
| 600              | 1.0  |                  |                   |   |     |     |     |     |      |     |     |     |      |     |      |     |      |     |      |     |      |     |      |      |      |      |      |      |      |      |      |      |      |      |      |      |      |      |      |      |      |      |      |      |      |      |      |      |      |      |      |      |      |      |      |                             |      |
| 700              | 1.02   |                  |                   |   |     |     |     |     |      |     |     |     |      |     |      |     |      |     |      |     |      |     |      |      |      |      |      |      |      |      |      |      |      |      |      |      |      |      |      |      |      |      |      |      |      |      |      |      |      |      |      |      |      |      |      |                             |      |
| 800              | 1.05   |                  |                   |   |     |     |     |     |      |     |     |     |      |     |      |     |      |     |      |     |      |     |      |      |      |      |      |      |      |      |      |      |      |      |      |      |      |      |      |      |      |      |      |      |      |      |      |      |      |      |      |      |      |      |      |                             |      |
| 900              | 1.08   |                  |                   |   |     |     |     |     |      |     |     |     |      |     |      |     |      |     |      |     |      |     |      |      |      |      |      |      |      |      |      |      |      |      |      |      |      |      |      |      |      |      |      |      |      |      |      |      |      |      |      |      |      |      |      |                             |      |
| 1000             | 1.1  |                  |                   |   |     |     |     |     |      |     |     |     |      |     |      |     |      |     |      |     |      |     |      |      |      |      |      |      |      |      |      |      |      |      |      |      |      |      |      |      |      |      |      |      |      |      |      |      |      |      |      |      |      |      |      |                             |      |
| 1100             | 1.1  |                  |                   |   |     |     |     |     |      |     |     |     |      |     |      |     |      |     |      |     |      |     |      |      |      |      |      |      |      |      |      |      |      |      |      |      |      |      |      |      |      |      |      |      |      |      |      |      |      |      |      |      |      |      |      |                             |      |
| 1200             | 1.1  |                  |                   |   |     |     |     |     |      |     |     |     |      |     |      |     |      |     |      |     |      |     |      |      |      |      |      |      |      |      |      |      |      |      |      |      |      |      |      |      |      |      |      |      |      |      |      |      |      |      |      |      |      |      |      |                             |      |
| 1300             | 1.1  |                  |                   |   |     |     |     |     |      |     |     |     |      |     |      |     |      |     |      |     |      |     |      |      |      |      |      |      |      |      |      |      |      |      |      |      |      |      |      |      |      |      |      |      |      |      |      |      |      |      |      |      |      |      |      |                             |      |
| 1400             | 1.1  |                  |                   |   |     |     |     |     |      |     |     |     |      |     |      |     |      |     |      |     |      |     |      |      |      |      |      |      |      |      |      |      |      |      |      |      |      |      |      |      |      |      |      |      |      |      |      |      |      |      |      |      |      |      |      |                             |      |
| 1500             | 1.1  |                  |                   |   |     |     |     |     |      |     |     |     |      |     |      |     |      |     |      |     |      |     |      |      |      |      |      |      |      |      |      |      |      |      |      |      |      |      |      |      |      |      |      |      |      |      |      |      |      |      |      |      |      |      |      |                             |      |
| 1600             | 1.1  |                  |                   |   |     |     |     |     |      |     |     |     |      |     |      |     |      |     |      |     |      |     |      |      |      |      |      |      |      |      |      |      |      |      |      |      |      |      |      |      |      |      |      |      |      |      |      |      |      |      |      |      |      |      |      |                             |      |
| 1700             | 1.1  |                  |                   |   |     |     |     |     |      |     |     |     |      |     |      |     |      |     |      |     |      |     |      |      |      |      |      |      |      |      |      |      |      |      |      |      |      |      |      |      |      |      |      |      |      |      |      |      |      |      |      |      |      |      |      |                             |      |
| 1800             | 1.1  |                  |                   |   |     |     |     |     |      |     |     |     |      |     |      |     |      |     |      |     |      |     |      |      |      |      |      |      |      |      |      |      |      |      |      |      |      |      |      |      |      |      |      |      |      |      |      |      |      |      |      |      |      |      |      |                             |      |
| 1900             | 1.1  |                  |                   |   |     |     |     |     |      |     |     |     |      |     |      |     |      |     |      |     |      |     |      |      |      |      |      |      |      |      |      |      |      |      |      |      |      |      |      |      |      |      |      |      |      |      |      |      |      |      |      |      |      |      |      |                             |      |
| 2000             | 1.1  |                  |                   |   |     |     |     |     |      |     |     |     |      |     |      |     |      |     |      |     |      |     |      |      |      |      |      |      |      |      |      |      |      |      |      |      |      |      |      |      |      |      |      |      |      |      |      |      |      |      |      |      |      |      |      |                             |      |
| 2100             | 1.1  |                  |                   |   |     |     |     |     |      |     |     |     |      |     |      |     |      |     |      |     |      |     |      |      |      |      |      |      |      |      |      |      |      |      |      |      |      |      |      |      |      |      |      |      |      |      |      |      |      |      |      |      |      |      |      |                             |      |
| 2200             | 1.1  |                  |                   |   |     |     |     |     |      |     |     |     |      |     |      |     |      |     |      |     |      |     |      |      |      |      |      |      |      |      |      |      |      |      |      |      |      |      |      |      |      |      |      |      |      |      |      |      |      |      |      |      |      |      |      |                             |      |
| 2300             | 1.1  |                  |                   |   |     |     |     |     |      |     |     |     |      |     |      |     |      |     |      |     |      |     |      |      |      |      |      |      |      |      |      |      |      |      |      |      |      |      |      |      |      |      |      |      |      |      |      |      |      |      |      |      |      |      |      |                             |      |
| 2400             | 1.1  |                  |                   |   |     |     |     |     |      |     |     |     |      |     |      |     |      |     |      |     |      |     |      |      |      |      |      |      |      |      |      |      |      |      |      |      |      |      |      |      |      |      |      |      |      |      |      |      |      |      |      |      |      |      |      |                             |      |
| 2500             | 1.1  |                  |                   |   |     |     |     |     |      |     |     |     |      |     |      |     |      |     |      |     |      |     |      |      |      |      |      |      |      |      |      |      |      |      |      |      |      |      |      |      |      |      |      |      |      |      |      |      |      |      |      |      |      |      |      |                             |      |

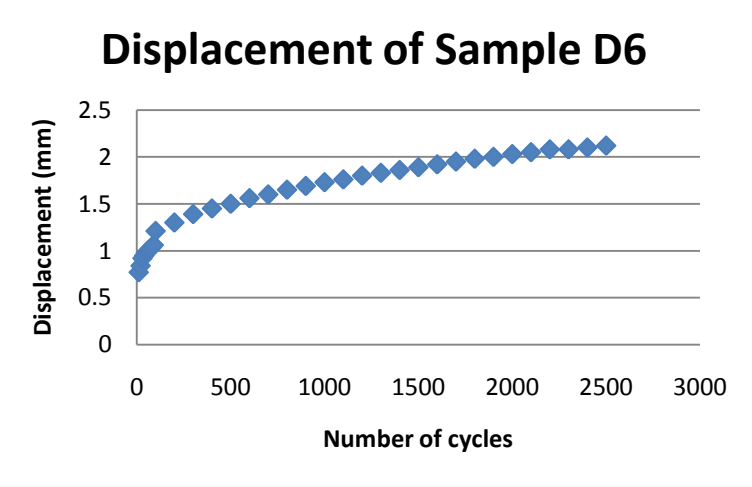
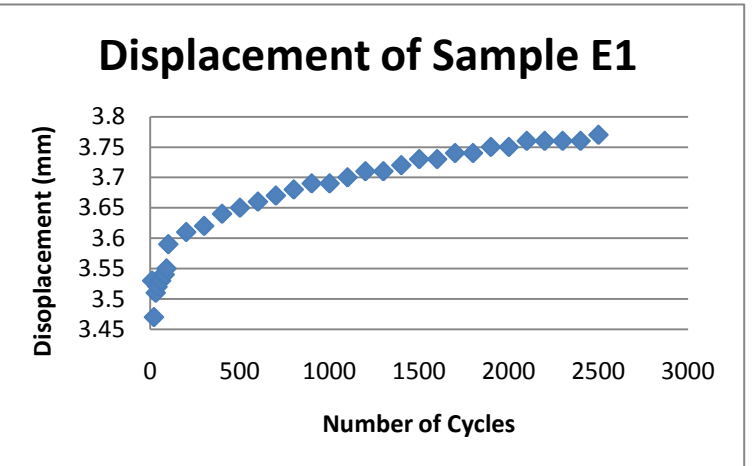
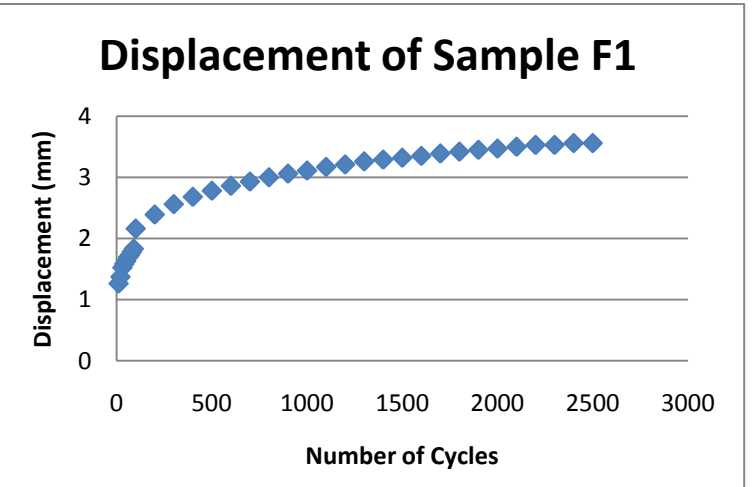

| <p>D6</p>        | <p style="text-align: center;"><b>Displacement of Sample D6</b></p>  <table border="1"> <caption>Approximate data for Sample D6</caption> <thead> <tr> <th>Number of cycles</th> <th>Displacement (mm)</th> </tr> </thead> <tbody> <tr><td>0</td><td>0.7</td></tr> <tr><td>100</td><td>1.1</td></tr> <tr><td>200</td><td>1.2</td></tr> <tr><td>300</td><td>1.3</td></tr> <tr><td>400</td><td>1.4</td></tr> <tr><td>500</td><td>1.45</td></tr> <tr><td>1000</td><td>1.6</td></tr> <tr><td>1500</td><td>1.8</td></tr> <tr><td>2000</td><td>1.95</td></tr> <tr><td>2500</td><td>2.1</td></tr> </tbody> </table>        | Number of cycles | Displacement (mm) | 0 | 0.7  | 100 | 1.1 | 200 | 1.2  | 300 | 1.3 | 400 | 1.4  | 500 | 1.45 | 1000 | 1.6  | 1500 | 1.8  | 2000 | 1.95 | 2500 | 2.1  | <p>Locking</p>     | <p>1.35</p> |
|------------------|---|------------------|-------------------|---|------|-----|-----|-----|------|-----|-----|-----|------|-----|------|------|------|------|------|------|------|------|------|--------------------|-------------|
| Number of cycles | Displacement (mm)   |                  |                   |   |      |     |     |     |      |     |     |     |      |     |      |      |      |      |      |      |      |      |      |                    |             |
| 0                | 0.7   |                  |                   |   |      |     |     |     |      |     |     |     |      |     |      |      |      |      |      |      |      |      |      |                    |             |
| 100              | 1.1   |                  |                   |   |      |     |     |     |      |     |     |     |      |     |      |      |      |      |      |      |      |      |      |                    |             |
| 200              | 1.2   |                  |                   |   |      |     |     |     |      |     |     |     |      |     |      |      |      |      |      |      |      |      |      |                    |             |
| 300              | 1.3   |                  |                   |   |      |     |     |     |      |     |     |     |      |     |      |      |      |      |      |      |      |      |      |                    |             |
| 400              | 1.4   |                  |                   |   |      |     |     |     |      |     |     |     |      |     |      |      |      |      |      |      |      |      |      |                    |             |
| 500              | 1.45  |                  |                   |   |      |     |     |     |      |     |     |     |      |     |      |      |      |      |      |      |      |      |      |                    |             |
| 1000             | 1.6   |                  |                   |   |      |     |     |     |      |     |     |     |      |     |      |      |      |      |      |      |      |      |      |                    |             |
| 1500             | 1.8   |                  |                   |   |      |     |     |     |      |     |     |     |      |     |      |      |      |      |      |      |      |      |      |                    |             |
| 2000             | 1.95  |                  |                   |   |      |     |     |     |      |     |     |     |      |     |      |      |      |      |      |      |      |      |      |                    |             |
| 2500             | 2.1   |                  |                   |   |      |     |     |     |      |     |     |     |      |     |      |      |      |      |      |      |      |      |      |                    |             |
| <p>E1</p>        | <p style="text-align: center;"><b>Displacement of Sample E1</b></p>  <table border="1"> <caption>Approximate data for Sample E1</caption> <thead> <tr> <th>Number of Cycles</th> <th>Displacement (mm)</th> </tr> </thead> <tbody> <tr><td>0</td><td>3.45</td></tr> <tr><td>100</td><td>3.5</td></tr> <tr><td>200</td><td>3.55</td></tr> <tr><td>300</td><td>3.6</td></tr> <tr><td>400</td><td>3.62</td></tr> <tr><td>500</td><td>3.64</td></tr> <tr><td>1000</td><td>3.68</td></tr> <tr><td>1500</td><td>3.72</td></tr> <tr><td>2000</td><td>3.74</td></tr> <tr><td>2500</td><td>3.75</td></tr> </tbody> </table> | Number of Cycles | Displacement (mm) | 0 | 3.45 | 100 | 3.5 | 200 | 3.55 | 300 | 3.6 | 400 | 3.62 | 500 | 3.64 | 1000 | 3.68 | 1500 | 3.72 | 2000 | 3.74 | 2500 | 3.75 | <p>Compression</p> | <p>0.79</p> |
| Number of Cycles | Displacement (mm)   |                  |                   |   |      |     |     |     |      |     |     |     |      |     |      |      |      |      |      |      |      |      |      |                    |             |
| 0                | 3.45  |                  |                   |   |      |     |     |     |      |     |     |     |      |     |      |      |      |      |      |      |      |      |      |                    |             |
| 100              | 3.5   |                  |                   |   |      |     |     |     |      |     |     |     |      |     |      |      |      |      |      |      |      |      |      |                    |             |
| 200              | 3.55  |                  |                   |   |      |     |     |     |      |     |     |     |      |     |      |      |      |      |      |      |      |      |      |                    |             |
| 300              | 3.6   |                  |                   |   |      |     |     |     |      |     |     |     |      |     |      |      |      |      |      |      |      |      |      |                    |             |
| 400              | 3.62  |                  |                   |   |      |     |     |     |      |     |     |     |      |     |      |      |      |      |      |      |      |      |      |                    |             |
| 500              | 3.64  |                  |                   |   |      |     |     |     |      |     |     |     |      |     |      |      |      |      |      |      |      |      |      |                    |             |
| 1000             | 3.68  |                  |                   |   |      |     |     |     |      |     |     |     |      |     |      |      |      |      |      |      |      |      |      |                    |             |
| 1500             | 3.72  |                  |                   |   |      |     |     |     |      |     |     |     |      |     |      |      |      |      |      |      |      |      |      |                    |             |
| 2000             | 3.74  |                  |                   |   |      |     |     |     |      |     |     |     |      |     |      |      |      |      |      |      |      |      |      |                    |             |
| 2500             | 3.75  |                  |                   |   |      |     |     |     |      |     |     |     |      |     |      |      |      |      |      |      |      |      |      |                    |             |
| <p>F1</p>        | <p style="text-align: center;"><b>Displacement of Sample F1</b></p>  <table border="1"> <caption>Approximate data for Sample F1</caption> <thead> <tr> <th>Number of Cycles</th> <th>Displacement (mm)</th> </tr> </thead> <tbody> <tr><td>0</td><td>1.2</td></tr> <tr><td>100</td><td>1.5</td></tr> <tr><td>200</td><td>1.8</td></tr> <tr><td>300</td><td>2.1</td></tr> <tr><td>400</td><td>2.3</td></tr> <tr><td>500</td><td>2.5</td></tr> <tr><td>1000</td><td>2.9</td></tr> <tr><td>1500</td><td>3.2</td></tr> <tr><td>2000</td><td>3.4</td></tr> <tr><td>2500</td><td>3.5</td></tr> </tbody> </table>        | Number of Cycles | Displacement (mm) | 0 | 1.2  | 100 | 1.5 | 200 | 1.8  | 300 | 2.1 | 400 | 2.3  | 500 | 2.5  | 1000 | 2.9  | 1500 | 3.2  | 2000 | 3.4  | 2500 | 3.5  | <p>Locking</p>     | <p>2.3</p>  |
| Number of Cycles | Displacement (mm)   |                  |                   |   |      |     |     |     |      |     |     |     |      |     |      |      |      |      |      |      |      |      |      |                    |             |
| 0                | 1.2   |                  |                   |   |      |     |     |     |      |     |     |     |      |     |      |      |      |      |      |      |      |      |      |                    |             |
| 100              | 1.5   |                  |                   |   |      |     |     |     |      |     |     |     |      |     |      |      |      |      |      |      |      |      |      |                    |             |
| 200              | 1.8   |                  |                   |   |      |     |     |     |      |     |     |     |      |     |      |      |      |      |      |      |      |      |      |                    |             |
| 300              | 2.1   |                  |                   |   |      |     |     |     |      |     |     |     |      |     |      |      |      |      |      |      |      |      |      |                    |             |
| 400              | 2.3   |                  |                   |   |      |     |     |     |      |     |     |     |      |     |      |      |      |      |      |      |      |      |      |                    |             |
| 500              | 2.5   |                  |                   |   |      |     |     |     |      |     |     |     |      |     |      |      |      |      |      |      |      |      |      |                    |             |
| 1000             | 2.9   |                  |                   |   |      |     |     |     |      |     |     |     |      |     |      |      |      |      |      |      |      |      |      |                    |             |
| 1500             | 3.2   |                  |                   |   |      |     |     |     |      |     |     |     |      |     |      |      |      |      |      |      |      |      |      |                    |             |
| 2000             | 3.4   |                  |                   |   |      |     |     |     |      |     |     |     |      |     |      |      |      |      |      |      |      |      |      |                    |             |
| 2500             | 3.5   |                  |                   |   |      |     |     |     |      |     |     |     |      |     |      |      |      |      |      |      |      |      |      |                    |             |

|    |  |             |        |
|----|--|-------------|--------|
| F2 | <p style="text-align: center;"><b>Displacement of sample F2</b></p> <p style="text-align: center;">Distance [mm]</p> <p style="text-align: center;"># of cycles</p>          | Locking     | 0.09   |
| F4 | <p style="text-align: center;"><b>Displacement of Sample F4</b></p> <p style="text-align: center;">Displacement (mm)</p> <p style="text-align: center;">Number of Cycles</p> | Locking     | 0.83   |
| F5 | <p style="text-align: center;"><b>Displacement of Sample F5</b></p> <p style="text-align: center;">Displacement (mm)</p> <p style="text-align: center;"># of cycles</p>      | Compression | 1.0777 |

| G1          | <p style="text-align: center;"><b>Displacement of Sample G1</b></p> <table border="1"> <caption>Approximate data for Sample G1</caption> <thead> <tr> <th># of Cycles</th> <th>Distance [mm]</th> </tr> </thead> <tbody> <tr><td>0</td><td>1.5</td></tr> <tr><td>100</td><td>3.0</td></tr> <tr><td>200</td><td>3.8</td></tr> <tr><td>300</td><td>4.2</td></tr> <tr><td>400</td><td>4.5</td></tr> <tr><td>500</td><td>4.7</td></tr> <tr><td>1000</td><td>5.0</td></tr> <tr><td>1500</td><td>5.2</td></tr> <tr><td>2000</td><td>5.4</td></tr> <tr><td>2500</td><td>5.5</td></tr> </tbody> </table> | # of Cycles | Distance [mm] | 0 | 1.5 | 100 | 3.0 | 200 | 3.8 | 300 | 4.2 | 400 | 4.5  | 500 | 4.7 | 1000 | 5.0 | 1500 | 5.2  | 2000 | 5.4 | 2500 | 5.5 | Bicortical | 4.16 |
|-------------|--|-------------|---------------|---|-----|-----|-----|-----|-----|-----|-----|-----|------|-----|-----|------|-----|------|------|------|-----|------|-----|------------|------|
| # of Cycles | Distance [mm]  |             |               |   |     |     |     |     |     |     |     |     |      |     |     |      |     |      |      |      |     |      |     |            |      |
| 0           | 1.5  |             |               |   |     |     |     |     |     |     |     |     |      |     |     |      |     |      |      |      |     |      |     |            |      |
| 100         | 3.0  |             |               |   |     |     |     |     |     |     |     |     |      |     |     |      |     |      |      |      |     |      |     |            |      |
| 200         | 3.8  |             |               |   |     |     |     |     |     |     |     |     |      |     |     |      |     |      |      |      |     |      |     |            |      |
| 300         | 4.2  |             |               |   |     |     |     |     |     |     |     |     |      |     |     |      |     |      |      |      |     |      |     |            |      |
| 400         | 4.5  |             |               |   |     |     |     |     |     |     |     |     |      |     |     |      |     |      |      |      |     |      |     |            |      |
| 500         | 4.7  |             |               |   |     |     |     |     |     |     |     |     |      |     |     |      |     |      |      |      |     |      |     |            |      |
| 1000        | 5.0  |             |               |   |     |     |     |     |     |     |     |     |      |     |     |      |     |      |      |      |     |      |     |            |      |
| 1500        | 5.2  |             |               |   |     |     |     |     |     |     |     |     |      |     |     |      |     |      |      |      |     |      |     |            |      |
| 2000        | 5.4  |             |               |   |     |     |     |     |     |     |     |     |      |     |     |      |     |      |      |      |     |      |     |            |      |
| 2500        | 5.5  |             |               |   |     |     |     |     |     |     |     |     |      |     |     |      |     |      |      |      |     |      |     |            |      |
| G2          | <p style="text-align: center;"><b>Displacement of Sample G2</b></p> <table border="1"> <caption>Approximate data for Sample G2</caption> <thead> <tr> <th># cycles</th> <th>Distance [mm]</th> </tr> </thead> <tbody> <tr><td>0</td><td>0.9</td></tr> <tr><td>100</td><td>1.0</td></tr> <tr><td>200</td><td>1.1</td></tr> <tr><td>300</td><td>1.2</td></tr> <tr><td>400</td><td>1.25</td></tr> <tr><td>500</td><td>1.3</td></tr> <tr><td>1000</td><td>1.4</td></tr> <tr><td>1500</td><td>1.45</td></tr> <tr><td>2000</td><td>1.5</td></tr> <tr><td>2500</td><td>1.6</td></tr> </tbody> </table>  | # cycles    | Distance [mm] | 0 | 0.9 | 100 | 1.0 | 200 | 1.1 | 300 | 1.2 | 400 | 1.25 | 500 | 1.3 | 1000 | 1.4 | 1500 | 1.45 | 2000 | 1.5 | 2500 | 1.6 | Bicortical | 0.6  |
| # cycles    | Distance [mm]  |             |               |   |     |     |     |     |     |     |     |     |      |     |     |      |     |      |      |      |     |      |     |            |      |
| 0           | 0.9  |             |               |   |     |     |     |     |     |     |     |     |      |     |     |      |     |      |      |      |     |      |     |            |      |
| 100         | 1.0  |             |               |   |     |     |     |     |     |     |     |     |      |     |     |      |     |      |      |      |     |      |     |            |      |
| 200         | 1.1  |             |               |   |     |     |     |     |     |     |     |     |      |     |     |      |     |      |      |      |     |      |     |            |      |
| 300         | 1.2  |             |               |   |     |     |     |     |     |     |     |     |      |     |     |      |     |      |      |      |     |      |     |            |      |
| 400         | 1.25   |             |               |   |     |     |     |     |     |     |     |     |      |     |     |      |     |      |      |      |     |      |     |            |      |
| 500         | 1.3  |             |               |   |     |     |     |     |     |     |     |     |      |     |     |      |     |      |      |      |     |      |     |            |      |
| 1000        | 1.4  |             |               |   |     |     |     |     |     |     |     |     |      |     |     |      |     |      |      |      |     |      |     |            |      |
| 1500        | 1.45   |             |               |   |     |     |     |     |     |     |     |     |      |     |     |      |     |      |      |      |     |      |     |            |      |
| 2000        | 1.5  |             |               |   |     |     |     |     |     |     |     |     |      |     |     |      |     |      |      |      |     |      |     |            |      |
| 2500        | 1.6  |             |               |   |     |     |     |     |     |     |     |     |      |     |     |      |     |      |      |      |     |      |     |            |      |
| G3          | <p style="text-align: center;"><b>Displacement of Sample G3</b></p> <table border="1"> <caption>Approximate data for Sample G3</caption> <thead> <tr> <th># of cycles</th> <th>Distance [mm]</th> </tr> </thead> <tbody> <tr><td>0</td><td>0.9</td></tr> <tr><td>100</td><td>1.1</td></tr> <tr><td>200</td><td>1.2</td></tr> <tr><td>300</td><td>1.3</td></tr> <tr><td>400</td><td>1.4</td></tr> <tr><td>500</td><td>1.5</td></tr> <tr><td>1000</td><td>1.8</td></tr> <tr><td>1500</td><td>2.1</td></tr> <tr><td>2000</td><td>2.4</td></tr> <tr><td>2500</td><td>3.0</td></tr> </tbody> </table> | # of cycles | Distance [mm] | 0 | 0.9 | 100 | 1.1 | 200 | 1.2 | 300 | 1.3 | 400 | 1.4  | 500 | 1.5 | 1000 | 1.8 | 1500 | 2.1  | 2000 | 2.4 | 2500 | 3.0 | Bicortical | 1.98 |
| # of cycles | Distance [mm]  |             |               |   |     |     |     |     |     |     |     |     |      |     |     |      |     |      |      |      |     |      |     |            |      |
| 0           | 0.9  |             |               |   |     |     |     |     |     |     |     |     |      |     |     |      |     |      |      |      |     |      |     |            |      |
| 100         | 1.1  |             |               |   |     |     |     |     |     |     |     |     |      |     |     |      |     |      |      |      |     |      |     |            |      |
| 200         | 1.2  |             |               |   |     |     |     |     |     |     |     |     |      |     |     |      |     |      |      |      |     |      |     |            |      |
| 300         | 1.3  |             |               |   |     |     |     |     |     |     |     |     |      |     |     |      |     |      |      |      |     |      |     |            |      |
| 400         | 1.4  |             |               |   |     |     |     |     |     |     |     |     |      |     |     |      |     |      |      |      |     |      |     |            |      |
| 500         | 1.5  |             |               |   |     |     |     |     |     |     |     |     |      |     |     |      |     |      |      |      |     |      |     |            |      |
| 1000        | 1.8  |             |               |   |     |     |     |     |     |     |     |     |      |     |     |      |     |      |      |      |     |      |     |            |      |
| 1500        | 2.1  |             |               |   |     |     |     |     |     |     |     |     |      |     |     |      |     |      |      |      |     |      |     |            |      |
| 2000        | 2.4  |             |               |   |     |     |     |     |     |     |     |     |      |     |     |      |     |      |      |      |     |      |     |            |      |
| 2500        | 3.0  |             |               |   |     |     |     |     |     |     |     |     |      |     |     |      |     |      |      |      |     |      |     |            |      |

| G4           | <p style="text-align: center;"><b>Displacement of Sample G4</b></p> <table border="1"> <caption>Approximate data for Sample G4</caption> <thead> <tr> <th># of cycles</th> <th>Distance [mm]</th> </tr> </thead> <tbody> <tr><td>0</td><td>0.9</td></tr> <tr><td>500</td><td>1.3</td></tr> <tr><td>1000</td><td>1.4</td></tr> <tr><td>1500</td><td>1.45</td></tr> <tr><td>2000</td><td>1.5</td></tr> <tr><td>2500</td><td>1.55</td></tr> </tbody> </table>    | # of cycles  | Distance [mm] | 0 | 0.9  | 500 | 1.3 | 1000 | 1.4  | 1500 | 1.45 | 2000 | 1.5  | 2500 | 1.55 | Bicortical | 0.61 |
|--------------|---|--------------|---------------|---|------|-----|-----|------|------|------|------|------|------|------|------|------------|------|
| # of cycles  | Distance [mm]   |              |               |   |      |     |     |      |      |      |      |      |      |      |      |            |      |
| 0            | 0.9   |              |               |   |      |     |     |      |      |      |      |      |      |      |      |            |      |
| 500          | 1.3   |              |               |   |      |     |     |      |      |      |      |      |      |      |      |            |      |
| 1000         | 1.4   |              |               |   |      |     |     |      |      |      |      |      |      |      |      |            |      |
| 1500         | 1.45  |              |               |   |      |     |     |      |      |      |      |      |      |      |      |            |      |
| 2000         | 1.5   |              |               |   |      |     |     |      |      |      |      |      |      |      |      |            |      |
| 2500         | 1.55  |              |               |   |      |     |     |      |      |      |      |      |      |      |      |            |      |
| G5           | <p style="text-align: center;"><b>Displacement of Sample G5</b></p> <table border="1"> <caption>Approximate data for Sample G5</caption> <thead> <tr> <th># of cycles</th> <th>Distance [mm]</th> </tr> </thead> <tbody> <tr><td>0</td><td>0.9</td></tr> <tr><td>500</td><td>1.3</td></tr> <tr><td>1000</td><td>1.4</td></tr> <tr><td>1500</td><td>1.5</td></tr> <tr><td>2000</td><td>1.55</td></tr> <tr><td>2500</td><td>1.6</td></tr> </tbody> </table>     | # of cycles  | Distance [mm] | 0 | 0.9  | 500 | 1.3 | 1000 | 1.4  | 1500 | 1.5  | 2000 | 1.55 | 2500 | 1.6  | Bicortical | 0.59 |
| # of cycles  | Distance [mm]   |              |               |   |      |     |     |      |      |      |      |      |      |      |      |            |      |
| 0            | 0.9   |              |               |   |      |     |     |      |      |      |      |      |      |      |      |            |      |
| 500          | 1.3   |              |               |   |      |     |     |      |      |      |      |      |      |      |      |            |      |
| 1000         | 1.4   |              |               |   |      |     |     |      |      |      |      |      |      |      |      |            |      |
| 1500         | 1.5   |              |               |   |      |     |     |      |      |      |      |      |      |      |      |            |      |
| 2000         | 1.55  |              |               |   |      |     |     |      |      |      |      |      |      |      |      |            |      |
| 2500         | 1.6   |              |               |   |      |     |     |      |      |      |      |      |      |      |      |            |      |
| G6           | <p style="text-align: center;"><b>Displacement of Sample G6</b></p> <table border="1"> <caption>Approximate data for Sample G6</caption> <thead> <tr> <th># of samples</th> <th>Distance [mm]</th> </tr> </thead> <tbody> <tr><td>0</td><td>0.65</td></tr> <tr><td>500</td><td>0.8</td></tr> <tr><td>1000</td><td>0.85</td></tr> <tr><td>1500</td><td>0.88</td></tr> <tr><td>2000</td><td>0.9</td></tr> <tr><td>2500</td><td>0.92</td></tr> </tbody> </table> | # of samples | Distance [mm] | 0 | 0.65 | 500 | 0.8 | 1000 | 0.85 | 1500 | 0.88 | 2000 | 0.9  | 2500 | 0.92 | Bicortical | 0.23 |
| # of samples | Distance [mm]   |              |               |   |      |     |     |      |      |      |      |      |      |      |      |            |      |
| 0            | 0.65  |              |               |   |      |     |     |      |      |      |      |      |      |      |      |            |      |
| 500          | 0.8   |              |               |   |      |     |     |      |      |      |      |      |      |      |      |            |      |
| 1000         | 0.85  |              |               |   |      |     |     |      |      |      |      |      |      |      |      |            |      |
| 1500         | 0.88  |              |               |   |      |     |     |      |      |      |      |      |      |      |      |            |      |
| 2000         | 0.9   |              |               |   |      |     |     |      |      |      |      |      |      |      |      |            |      |
| 2500         | 0.92  |              |               |   |      |     |     |      |      |      |      |      |      |      |      |            |      |

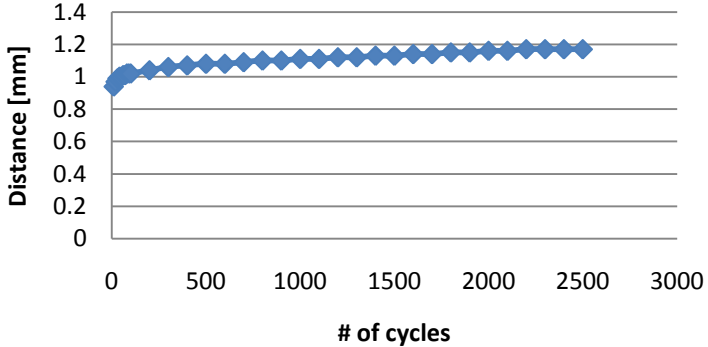
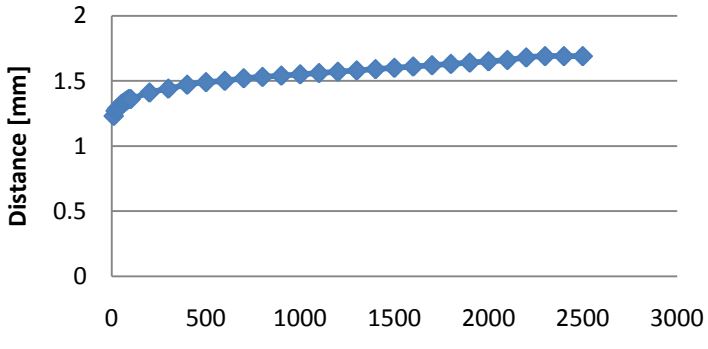
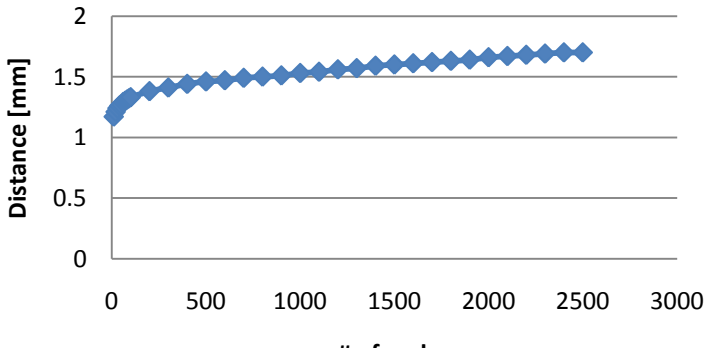
| H1          | <p style="text-align: center;"><b>Displacement of Sample H1</b></p>  <table border="1"> <caption>Approximate data for Sample H1</caption> <thead> <tr> <th># of cycles</th> <th>Distance [mm]</th> </tr> </thead> <tbody> <tr><td>0</td><td>0.95</td></tr> <tr><td>500</td><td>1.05</td></tr> <tr><td>1000</td><td>1.10</td></tr> <tr><td>1500</td><td>1.12</td></tr> <tr><td>2000</td><td>1.14</td></tr> <tr><td>2500</td><td>1.15</td></tr> </tbody> </table>   | # of cycles | Distance [mm] | 0 | 0.95 | 500 | 1.05 | 1000 | 1.10 | 1500 | 1.12 | 2000 | 1.14 | 2500 | 1.15 | Bicortical | 0.23 |
|-------------|---|-------------|---------------|---|------|-----|------|------|------|------|------|------|------|------|------|------------|------|
| # of cycles | Distance [mm]   |             |               |   |      |     |      |      |      |      |      |      |      |      |      |            |      |
| 0           | 0.95  |             |               |   |      |     |      |      |      |      |      |      |      |      |      |            |      |
| 500         | 1.05  |             |               |   |      |     |      |      |      |      |      |      |      |      |      |            |      |
| 1000        | 1.10  |             |               |   |      |     |      |      |      |      |      |      |      |      |      |            |      |
| 1500        | 1.12  |             |               |   |      |     |      |      |      |      |      |      |      |      |      |            |      |
| 2000        | 1.14  |             |               |   |      |     |      |      |      |      |      |      |      |      |      |            |      |
| 2500        | 1.15  |             |               |   |      |     |      |      |      |      |      |      |      |      |      |            |      |
| H3          | <p style="text-align: center;"><b>Displacement of Sample H3</b></p>  <table border="1"> <caption>Approximate data for Sample H3</caption> <thead> <tr> <th># of cycles</th> <th>Distance [mm]</th> </tr> </thead> <tbody> <tr><td>0</td><td>1.25</td></tr> <tr><td>500</td><td>1.45</td></tr> <tr><td>1000</td><td>1.55</td></tr> <tr><td>1500</td><td>1.60</td></tr> <tr><td>2000</td><td>1.65</td></tr> <tr><td>2500</td><td>1.70</td></tr> </tbody> </table>  | # of cycles | Distance [mm] | 0 | 1.25 | 500 | 1.45 | 1000 | 1.55 | 1500 | 1.60 | 2000 | 1.65 | 2500 | 1.70 | Locking    | 0.46 |
| # of cycles | Distance [mm]   |             |               |   |      |     |      |      |      |      |      |      |      |      |      |            |      |
| 0           | 1.25  |             |               |   |      |     |      |      |      |      |      |      |      |      |      |            |      |
| 500         | 1.45  |             |               |   |      |     |      |      |      |      |      |      |      |      |      |            |      |
| 1000        | 1.55  |             |               |   |      |     |      |      |      |      |      |      |      |      |      |            |      |
| 1500        | 1.60  |             |               |   |      |     |      |      |      |      |      |      |      |      |      |            |      |
| 2000        | 1.65  |             |               |   |      |     |      |      |      |      |      |      |      |      |      |            |      |
| 2500        | 1.70  |             |               |   |      |     |      |      |      |      |      |      |      |      |      |            |      |
| J1          | <p style="text-align: center;"><b>Displacement of Sample J1</b></p>  <table border="1"> <caption>Approximate data for Sample J1</caption> <thead> <tr> <th># of cycles</th> <th>Distance [mm]</th> </tr> </thead> <tbody> <tr><td>0</td><td>1.15</td></tr> <tr><td>500</td><td>1.45</td></tr> <tr><td>1000</td><td>1.55</td></tr> <tr><td>1500</td><td>1.60</td></tr> <tr><td>2000</td><td>1.65</td></tr> <tr><td>2500</td><td>1.70</td></tr> </tbody> </table> | # of cycles | Distance [mm] | 0 | 1.15 | 500 | 1.45 | 1000 | 1.55 | 1500 | 1.60 | 2000 | 1.65 | 2500 | 1.70 | Uncortical | 0.53 |
| # of cycles | Distance [mm]   |             |               |   |      |     |      |      |      |      |      |      |      |      |      |            |      |
| 0           | 1.15  |             |               |   |      |     |      |      |      |      |      |      |      |      |      |            |      |
| 500         | 1.45  |             |               |   |      |     |      |      |      |      |      |      |      |      |      |            |      |
| 1000        | 1.55  |             |               |   |      |     |      |      |      |      |      |      |      |      |      |            |      |
| 1500        | 1.60  |             |               |   |      |     |      |      |      |      |      |      |      |      |      |            |      |
| 2000        | 1.65  |             |               |   |      |     |      |      |      |      |      |      |      |      |      |            |      |
| 2500        | 1.70  |             |               |   |      |     |      |      |      |      |      |      |      |      |      |            |      |

|           |   |                   |             |
|-----------|---|-------------------|-------------|
| <p>J2</p> | <p style="text-align: center;"><b>Displacement of Sample J2</b></p> <p style="text-align: center;"># of cycles</p>  | <p>Uncortical</p> | <p>0.84</p> |
| <p>J3</p> | <p style="text-align: center;"><b>Displacement of Sample J3</b></p> <p style="text-align: center;"># of cycles</p>  | <p>Uncortical</p> | <p>0.82</p> |
| <p>J4</p> | <p style="text-align: center;"><b>Displacement of Sample J4</b></p> <p style="text-align: center;"># of samples</p> | <p>Uncortical</p> | <p>1.72</p> |

| J5          | <p style="text-align: center;"><b>Displacement of Sample J5</b></p> <table border="1"> <caption>Approximate data for Displacement of Sample J5</caption> <thead> <tr> <th># of cycles</th> <th>Distance [mm]</th> </tr> </thead> <tbody> <tr><td>0</td><td>1.3</td></tr> <tr><td>500</td><td>1.8</td></tr> <tr><td>1000</td><td>2.0</td></tr> <tr><td>1500</td><td>2.2</td></tr> <tr><td>2000</td><td>2.5</td></tr> <tr><td>2500</td><td>2.8</td></tr> </tbody> </table>            | # of cycles | Distance [mm]   | 0 | 1.3  | 500 | 1.8  | 1000 | 2.0  | 1500 | 2.2  | 2000 | 2.5  | 2500 | 2.8 | Unicortical | 1.5  |
|-------------|---|-------------|-----------------|---|------|-----|------|------|------|------|------|------|------|------|-----|-------------|------|
| # of cycles | Distance [mm]   |             |                 |   |      |     |      |      |      |      |      |      |      |      |     |             |      |
| 0           | 1.3   |             |                 |   |      |     |      |      |      |      |      |      |      |      |     |             |      |
| 500         | 1.8   |             |                 |   |      |     |      |      |      |      |      |      |      |      |     |             |      |
| 1000        | 2.0   |             |                 |   |      |     |      |      |      |      |      |      |      |      |     |             |      |
| 1500        | 2.2   |             |                 |   |      |     |      |      |      |      |      |      |      |      |     |             |      |
| 2000        | 2.5   |             |                 |   |      |     |      |      |      |      |      |      |      |      |     |             |      |
| 2500        | 2.8   |             |                 |   |      |     |      |      |      |      |      |      |      |      |     |             |      |
| J6          | <p style="text-align: center;"><b>Displacement of Sample J6</b></p> <table border="1"> <caption>Approximate data for Displacement of Sample J6</caption> <thead> <tr> <th># of cycles</th> <th>Distance [mm]</th> </tr> </thead> <tbody> <tr><td>0</td><td>0.9</td></tr> <tr><td>500</td><td>1.0</td></tr> <tr><td>1000</td><td>1.05</td></tr> <tr><td>1500</td><td>1.08</td></tr> <tr><td>2000</td><td>1.1</td></tr> <tr><td>2500</td><td>1.1</td></tr> </tbody> </table>          | # of cycles | Distance [mm]   | 0 | 0.9  | 500 | 1.0  | 1000 | 1.05 | 1500 | 1.08 | 2000 | 1.1  | 2500 | 1.1 | Unicortical | 0.23 |
| # of cycles | Distance [mm]   |             |                 |   |      |     |      |      |      |      |      |      |      |      |     |             |      |
| 0           | 0.9   |             |                 |   |      |     |      |      |      |      |      |      |      |      |     |             |      |
| 500         | 1.0   |             |                 |   |      |     |      |      |      |      |      |      |      |      |     |             |      |
| 1000        | 1.05  |             |                 |   |      |     |      |      |      |      |      |      |      |      |     |             |      |
| 1500        | 1.08  |             |                 |   |      |     |      |      |      |      |      |      |      |      |     |             |      |
| 2000        | 1.1   |             |                 |   |      |     |      |      |      |      |      |      |      |      |     |             |      |
| 2500        | 1.1   |             |                 |   |      |     |      |      |      |      |      |      |      |      |     |             |      |
| Cad. 1      | <p style="text-align: center;"><b>Bone Separation for Cadaver 1</b></p> <table border="1"> <caption>Approximate data for Bone Separation for Cadaver 1</caption> <thead> <tr> <th># Cycles</th> <th>Separation [mm]</th> </tr> </thead> <tbody> <tr><td>0</td><td>0.65</td></tr> <tr><td>500</td><td>0.85</td></tr> <tr><td>1000</td><td>0.9</td></tr> <tr><td>1500</td><td>0.95</td></tr> <tr><td>2000</td><td>0.98</td></tr> <tr><td>2500</td><td>1.0</td></tr> </tbody> </table> | # Cycles    | Separation [mm] | 0 | 0.65 | 500 | 0.85 | 1000 | 0.9  | 1500 | 0.95 | 2000 | 0.98 | 2500 | 1.0 | Unicortical | 1.01 |
| # Cycles    | Separation [mm]   |             |                 |   |      |     |      |      |      |      |      |      |      |      |     |             |      |
| 0           | 0.65  |             |                 |   |      |     |      |      |      |      |      |      |      |      |     |             |      |
| 500         | 0.85  |             |                 |   |      |     |      |      |      |      |      |      |      |      |     |             |      |
| 1000        | 0.9   |             |                 |   |      |     |      |      |      |      |      |      |      |      |     |             |      |
| 1500        | 0.95  |             |                 |   |      |     |      |      |      |      |      |      |      |      |     |             |      |
| 2000        | 0.98  |             |                 |   |      |     |      |      |      |      |      |      |      |      |     |             |      |
| 2500        | 1.0   |             |                 |   |      |     |      |      |      |      |      |      |      |      |     |             |      |

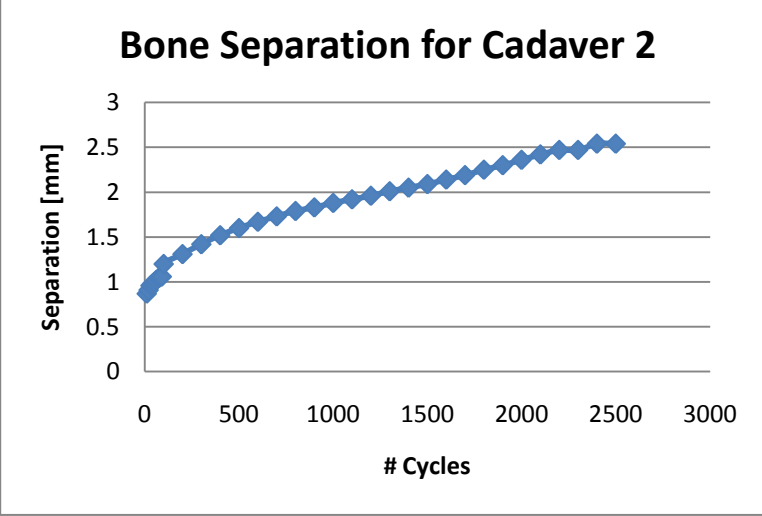
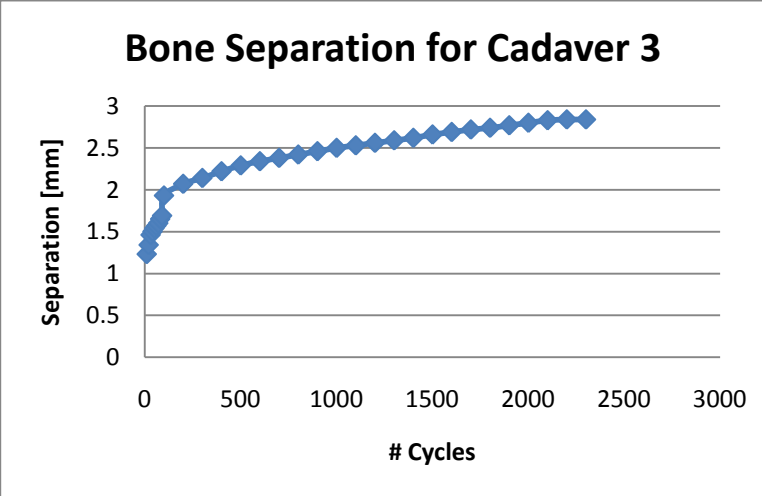
| Cad. 2   | <p style="text-align: center;"><b>Bone Separation for Cadaver 2</b></p>  <table border="1" data-bbox="316 199 1073 711"> <caption>Approximate data for Cadaver 2</caption> <thead> <tr> <th># Cycles</th> <th>Separation [mm]</th> </tr> </thead> <tbody> <tr><td>0</td><td>0.8</td></tr> <tr><td>500</td><td>1.5</td></tr> <tr><td>1000</td><td>1.9</td></tr> <tr><td>1500</td><td>2.1</td></tr> <tr><td>2000</td><td>2.3</td></tr> <tr><td>2500</td><td>2.5</td></tr> </tbody> </table>   | # Cycles   | Separation [mm] | 0 | 0.8 | 500 | 1.5 | 1000 | 1.9 | 1500 | 2.1 | 2000 | 2.3 | 2500 | 2.5 | Unicortical | 1.67 |
|----------|---|------------|-----------------|---|-----|-----|-----|------|-----|------|-----|------|-----|------|-----|-------------|------|
| # Cycles | Separation [mm]   |            |                 |   |     |     |     |      |     |      |     |      |     |      |     |             |      |
| 0        | 0.8   |            |                 |   |     |     |     |      |     |      |     |      |     |      |     |             |      |
| 500      | 1.5   |            |                 |   |     |     |     |      |     |      |     |      |     |      |     |             |      |
| 1000     | 1.9   |            |                 |   |     |     |     |      |     |      |     |      |     |      |     |             |      |
| 1500     | 2.1   |            |                 |   |     |     |     |      |     |      |     |      |     |      |     |             |      |
| 2000     | 2.3   |            |                 |   |     |     |     |      |     |      |     |      |     |      |     |             |      |
| 2500     | 2.5   |            |                 |   |     |     |     |      |     |      |     |      |     |      |     |             |      |
| Cad. 3   | <p style="text-align: center;"><b>Bone Separation for Cadaver 3</b></p>  <table border="1" data-bbox="316 770 1073 1262"> <caption>Approximate data for Cadaver 3</caption> <thead> <tr> <th># Cycles</th> <th>Separation [mm]</th> </tr> </thead> <tbody> <tr><td>0</td><td>1.2</td></tr> <tr><td>500</td><td>2.2</td></tr> <tr><td>1000</td><td>2.4</td></tr> <tr><td>1500</td><td>2.6</td></tr> <tr><td>2000</td><td>2.7</td></tr> <tr><td>2300</td><td>2.8</td></tr> </tbody> </table> | # Cycles   | Separation [mm] | 0 | 1.2 | 500 | 2.2 | 1000 | 2.4 | 1500 | 2.6 | 2000 | 2.7 | 2300 | 2.8 | Unicortical | 1.61 |
| # Cycles | Separation [mm]   |            |                 |   |     |     |     |      |     |      |     |      |     |      |     |             |      |
| 0        | 1.2   |            |                 |   |     |     |     |      |     |      |     |      |     |      |     |             |      |
| 500      | 2.2   |            |                 |   |     |     |     |      |     |      |     |      |     |      |     |             |      |
| 1000     | 2.4   |            |                 |   |     |     |     |      |     |      |     |      |     |      |     |             |      |
| 1500     | 2.6   |            |                 |   |     |     |     |      |     |      |     |      |     |      |     |             |      |
| 2000     | 2.7   |            |                 |   |     |     |     |      |     |      |     |      |     |      |     |             |      |
| 2300     | 2.8   |            |                 |   |     |     |     |      |     |      |     |      |     |      |     |             |      |
| Cad. 4   | Setup failure – screws wobble in one rib half   | Bicortical | fail            |   |     |     |     |      |     |      |     |      |     |      |     |             |      |



| <p>Cad. 5</p> | <p style="text-align: center;"><b>Bone Separation for Cadaver 5</b></p> <table border="1"> <caption>Approximate data for Cadaver 5</caption> <thead> <tr> <th># Cycles</th> <th>Separation [mm]</th> </tr> </thead> <tbody> <tr><td>0</td><td>1.2</td></tr> <tr><td>100</td><td>1.8</td></tr> <tr><td>200</td><td>2.2</td></tr> <tr><td>300</td><td>2.4</td></tr> <tr><td>400</td><td>2.6</td></tr> <tr><td>500</td><td>2.8</td></tr> <tr><td>600</td><td>3.0</td></tr> <tr><td>700</td><td>3.2</td></tr> <tr><td>800</td><td>3.4</td></tr> <tr><td>900</td><td>3.5</td></tr> <tr><td>1000</td><td>3.6</td></tr> <tr><td>1100</td><td>3.7</td></tr> <tr><td>1200</td><td>3.8</td></tr> <tr><td>1300</td><td>3.9</td></tr> <tr><td>1400</td><td>4.0</td></tr> <tr><td>1500</td><td>4.1</td></tr> <tr><td>1600</td><td>4.2</td></tr> <tr><td>1700</td><td>4.3</td></tr> <tr><td>1800</td><td>4.4</td></tr> <tr><td>1900</td><td>4.4</td></tr> <tr><td>2000</td><td>4.5</td></tr> <tr><td>2100</td><td>4.5</td></tr> <tr><td>2200</td><td>4.5</td></tr> <tr><td>2300</td><td>4.5</td></tr> <tr><td>2400</td><td>4.5</td></tr> <tr><td>2500</td><td>4.5</td></tr> </tbody> </table> | # Cycles | Separation [mm] | 0 | 1.2 | 100 | 1.8 | 200 | 2.2 | 300 | 2.4 | 400 | 2.6 | 500 | 2.8 | 600 | 3.0 | 700 | 3.2 | 800 | 3.4 | 900 | 3.5 | 1000 | 3.6 | 1100 | 3.7 | 1200 | 3.8 | 1300 | 3.9 | 1400 | 4.0 | 1500 | 4.1 | 1600 | 4.2 | 1700 | 4.3 | 1800 | 4.4 | 1900              | 4.4         | 2000 | 4.5 | 2100 | 4.5 | 2200 | 4.5 | 2300 | 4.5 | 2400 | 4.5 | 2500 | 4.5 | <p>Bicortical</p> | <p>3.28</p> |
|---------------|---|----------|-----------------|---|-----|-----|-----|-----|-----|-----|-----|-----|-----|-----|-----|-----|-----|-----|-----|-----|-----|-----|-----|------|-----|------|-----|------|-----|------|-----|------|-----|------|-----|------|-----|------|-----|------|-----|-------------------|-------------|------|-----|------|-----|------|-----|------|-----|------|-----|------|-----|-------------------|-------------|
| # Cycles      | Separation [mm]   |          |                 |   |     |     |     |     |     |     |     |     |     |     |     |     |     |     |     |     |     |     |     |      |     |      |     |      |     |      |     |      |     |      |     |      |     |      |     |      |     |                   |             |      |     |      |     |      |     |      |     |      |     |      |     |                   |             |
| 0             | 1.2   |          |                 |   |     |     |     |     |     |     |     |     |     |     |     |     |     |     |     |     |     |     |     |      |     |      |     |      |     |      |     |      |     |      |     |      |     |      |     |      |     |                   |             |      |     |      |     |      |     |      |     |      |     |      |     |                   |             |
| 100           | 1.8   |          |                 |   |     |     |     |     |     |     |     |     |     |     |     |     |     |     |     |     |     |     |     |      |     |      |     |      |     |      |     |      |     |      |     |      |     |      |     |      |     |                   |             |      |     |      |     |      |     |      |     |      |     |      |     |                   |             |
| 200           | 2.2   |          |                 |   |     |     |     |     |     |     |     |     |     |     |     |     |     |     |     |     |     |     |     |      |     |      |     |      |     |      |     |      |     |      |     |      |     |      |     |      |     |                   |             |      |     |      |     |      |     |      |     |      |     |      |     |                   |             |
| 300           | 2.4   |          |                 |   |     |     |     |     |     |     |     |     |     |     |     |     |     |     |     |     |     |     |     |      |     |      |     |      |     |      |     |      |     |      |     |      |     |      |     |      |     |                   |             |      |     |      |     |      |     |      |     |      |     |      |     |                   |             |
| 400           | 2.6   |          |                 |   |     |     |     |     |     |     |     |     |     |     |     |     |     |     |     |     |     |     |     |      |     |      |     |      |     |      |     |      |     |      |     |      |     |      |     |      |     |                   |             |      |     |      |     |      |     |      |     |      |     |      |     |                   |             |
| 500           | 2.8   |          |                 |   |     |     |     |     |     |     |     |     |     |     |     |     |     |     |     |     |     |     |     |      |     |      |     |      |     |      |     |      |     |      |     |      |     |      |     |      |     |                   |             |      |     |      |     |      |     |      |     |      |     |      |     |                   |             |
| 600           | 3.0   |          |                 |   |     |     |     |     |     |     |     |     |     |     |     |     |     |     |     |     |     |     |     |      |     |      |     |      |     |      |     |      |     |      |     |      |     |      |     |      |     |                   |             |      |     |      |     |      |     |      |     |      |     |      |     |                   |             |
| 700           | 3.2   |          |                 |   |     |     |     |     |     |     |     |     |     |     |     |     |     |     |     |     |     |     |     |      |     |      |     |      |     |      |     |      |     |      |     |      |     |      |     |      |     |                   |             |      |     |      |     |      |     |      |     |      |     |      |     |                   |             |
| 800           | 3.4   |          |                 |   |     |     |     |     |     |     |     |     |     |     |     |     |     |     |     |     |     |     |     |      |     |      |     |      |     |      |     |      |     |      |     |      |     |      |     |      |     |                   |             |      |     |      |     |      |     |      |     |      |     |      |     |                   |             |
| 900           | 3.5   |          |                 |   |     |     |     |     |     |     |     |     |     |     |     |     |     |     |     |     |     |     |     |      |     |      |     |      |     |      |     |      |     |      |     |      |     |      |     |      |     |                   |             |      |     |      |     |      |     |      |     |      |     |      |     |                   |             |
| 1000          | 3.6   |          |                 |   |     |     |     |     |     |     |     |     |     |     |     |     |     |     |     |     |     |     |     |      |     |      |     |      |     |      |     |      |     |      |     |      |     |      |     |      |     |                   |             |      |     |      |     |      |     |      |     |      |     |      |     |                   |             |
| 1100          | 3.7   |          |                 |   |     |     |     |     |     |     |     |     |     |     |     |     |     |     |     |     |     |     |     |      |     |      |     |      |     |      |     |      |     |      |     |      |     |      |     |      |     |                   |             |      |     |      |     |      |     |      |     |      |     |      |     |                   |             |
| 1200          | 3.8   |          |                 |   |     |     |     |     |     |     |     |     |     |     |     |     |     |     |     |     |     |     |     |      |     |      |     |      |     |      |     |      |     |      |     |      |     |      |     |      |     |                   |             |      |     |      |     |      |     |      |     |      |     |      |     |                   |             |
| 1300          | 3.9   |          |                 |   |     |     |     |     |     |     |     |     |     |     |     |     |     |     |     |     |     |     |     |      |     |      |     |      |     |      |     |      |     |      |     |      |     |      |     |      |     |                   |             |      |     |      |     |      |     |      |     |      |     |      |     |                   |             |
| 1400          | 4.0   |          |                 |   |     |     |     |     |     |     |     |     |     |     |     |     |     |     |     |     |     |     |     |      |     |      |     |      |     |      |     |      |     |      |     |      |     |      |     |      |     |                   |             |      |     |      |     |      |     |      |     |      |     |      |     |                   |             |
| 1500          | 4.1   |          |                 |   |     |     |     |     |     |     |     |     |     |     |     |     |     |     |     |     |     |     |     |      |     |      |     |      |     |      |     |      |     |      |     |      |     |      |     |      |     |                   |             |      |     |      |     |      |     |      |     |      |     |      |     |                   |             |
| 1600          | 4.2   |          |                 |   |     |     |     |     |     |     |     |     |     |     |     |     |     |     |     |     |     |     |     |      |     |      |     |      |     |      |     |      |     |      |     |      |     |      |     |      |     |                   |             |      |     |      |     |      |     |      |     |      |     |      |     |                   |             |
| 1700          | 4.3   |          |                 |   |     |     |     |     |     |     |     |     |     |     |     |     |     |     |     |     |     |     |     |      |     |      |     |      |     |      |     |      |     |      |     |      |     |      |     |      |     |                   |             |      |     |      |     |      |     |      |     |      |     |      |     |                   |             |
| 1800          | 4.4   |          |                 |   |     |     |     |     |     |     |     |     |     |     |     |     |     |     |     |     |     |     |     |      |     |      |     |      |     |      |     |      |     |      |     |      |     |      |     |      |     |                   |             |      |     |      |     |      |     |      |     |      |     |      |     |                   |             |
| 1900          | 4.4   |          |                 |   |     |     |     |     |     |     |     |     |     |     |     |     |     |     |     |     |     |     |     |      |     |      |     |      |     |      |     |      |     |      |     |      |     |      |     |      |     |                   |             |      |     |      |     |      |     |      |     |      |     |      |     |                   |             |
| 2000          | 4.5   |          |                 |   |     |     |     |     |     |     |     |     |     |     |     |     |     |     |     |     |     |     |     |      |     |      |     |      |     |      |     |      |     |      |     |      |     |      |     |      |     |                   |             |      |     |      |     |      |     |      |     |      |     |      |     |                   |             |
| 2100          | 4.5   |          |                 |   |     |     |     |     |     |     |     |     |     |     |     |     |     |     |     |     |     |     |     |      |     |      |     |      |     |      |     |      |     |      |     |      |     |      |     |      |     |                   |             |      |     |      |     |      |     |      |     |      |     |      |     |                   |             |
| 2200          | 4.5   |          |                 |   |     |     |     |     |     |     |     |     |     |     |     |     |     |     |     |     |     |     |     |      |     |      |     |      |     |      |     |      |     |      |     |      |     |      |     |      |     |                   |             |      |     |      |     |      |     |      |     |      |     |      |     |                   |             |
| 2300          | 4.5   |          |                 |   |     |     |     |     |     |     |     |     |     |     |     |     |     |     |     |     |     |     |     |      |     |      |     |      |     |      |     |      |     |      |     |      |     |      |     |      |     |                   |             |      |     |      |     |      |     |      |     |      |     |      |     |                   |             |
| 2400          | 4.5   |          |                 |   |     |     |     |     |     |     |     |     |     |     |     |     |     |     |     |     |     |     |     |      |     |      |     |      |     |      |     |      |     |      |     |      |     |      |     |      |     |                   |             |      |     |      |     |      |     |      |     |      |     |      |     |                   |             |
| 2500          | 4.5   |          |                 |   |     |     |     |     |     |     |     |     |     |     |     |     |     |     |     |     |     |     |     |      |     |      |     |      |     |      |     |      |     |      |     |      |     |      |     |      |     |                   |             |      |     |      |     |      |     |      |     |      |     |      |     |                   |             |
| <p>Cad. 6</p> | <p style="text-align: center;"><b>Bone Separation for Cadaver 6</b></p> <table border="1"> <caption>Approximate data for Cadaver 6</caption> <thead> <tr> <th># Cycles</th> <th>Separation [mm]</th> </tr> </thead> <tbody> <tr><td>0</td><td>2.8</td></tr> <tr><td>100</td><td>3.5</td></tr> <tr><td>200</td><td>4.2</td></tr> <tr><td>300</td><td>4.5</td></tr> <tr><td>400</td><td>4.7</td></tr> <tr><td>500</td><td>4.8</td></tr> <tr><td>600</td><td>4.9</td></tr> <tr><td>700</td><td>5.0</td></tr> <tr><td>800</td><td>5.1</td></tr> <tr><td>900</td><td>5.2</td></tr> <tr><td>1000</td><td>5.3</td></tr> <tr><td>1100</td><td>5.4</td></tr> <tr><td>1200</td><td>5.5</td></tr> <tr><td>1300</td><td>5.6</td></tr> <tr><td>1400</td><td>5.7</td></tr> <tr><td>1500</td><td>5.8</td></tr> <tr><td>1600</td><td>5.9</td></tr> <tr><td>1700</td><td>6.0</td></tr> <tr><td>1800</td><td>6.5</td></tr> </tbody> </table>  | # Cycles | Separation [mm] | 0 | 2.8 | 100 | 3.5 | 200 | 4.2 | 300 | 4.5 | 400 | 4.7 | 500 | 4.8 | 600 | 4.9 | 700 | 5.0 | 800 | 5.1 | 900 | 5.2 | 1000 | 5.3 | 1100 | 5.4 | 1200 | 5.5 | 1300 | 5.6 | 1400 | 5.7 | 1500 | 5.8 | 1600 | 5.9 | 1700 | 6.0 | 1800 | 6.5 | <p>Bicortical</p> | <p>3.63</p> |      |     |      |     |      |     |      |     |      |     |      |     |                   |             |
| # Cycles      | Separation [mm]   |          |                 |   |     |     |     |     |     |     |     |     |     |     |     |     |     |     |     |     |     |     |     |      |     |      |     |      |     |      |     |      |     |      |     |      |     |      |     |      |     |                   |             |      |     |      |     |      |     |      |     |      |     |      |     |                   |             |
| 0             | 2.8   |          |                 |   |     |     |     |     |     |     |     |     |     |     |     |     |     |     |     |     |     |     |     |      |     |      |     |      |     |      |     |      |     |      |     |      |     |      |     |      |     |                   |             |      |     |      |     |      |     |      |     |      |     |      |     |                   |             |
| 100           | 3.5   |          |                 |   |     |     |     |     |     |     |     |     |     |     |     |     |     |     |     |     |     |     |     |      |     |      |     |      |     |      |     |      |     |      |     |      |     |      |     |      |     |                   |             |      |     |      |     |      |     |      |     |      |     |      |     |                   |             |
| 200           | 4.2   |          |                 |   |     |     |     |     |     |     |     |     |     |     |     |     |     |     |     |     |     |     |     |      |     |      |     |      |     |      |     |      |     |      |     |      |     |      |     |      |     |                   |             |      |     |      |     |      |     |      |     |      |     |      |     |                   |             |
| 300           | 4.5   |          |                 |   |     |     |     |     |     |     |     |     |     |     |     |     |     |     |     |     |     |     |     |      |     |      |     |      |     |      |     |      |     |      |     |      |     |      |     |      |     |                   |             |      |     |      |     |      |     |      |     |      |     |      |     |                   |             |
| 400           | 4.7   |          |                 |   |     |     |     |     |     |     |     |     |     |     |     |     |     |     |     |     |     |     |     |      |     |      |     |      |     |      |     |      |     |      |     |      |     |      |     |      |     |                   |             |      |     |      |     |      |     |      |     |      |     |      |     |                   |             |
| 500           | 4.8   |          |                 |   |     |     |     |     |     |     |     |     |     |     |     |     |     |     |     |     |     |     |     |      |     |      |     |      |     |      |     |      |     |      |     |      |     |      |     |      |     |                   |             |      |     |      |     |      |     |      |     |      |     |      |     |                   |             |
| 600           | 4.9   |          |                 |   |     |     |     |     |     |     |     |     |     |     |     |     |     |     |     |     |     |     |     |      |     |      |     |      |     |      |     |      |     |      |     |      |     |      |     |      |     |                   |             |      |     |      |     |      |     |      |     |      |     |      |     |                   |             |
| 700           | 5.0   |          |                 |   |     |     |     |     |     |     |     |     |     |     |     |     |     |     |     |     |     |     |     |      |     |      |     |      |     |      |     |      |     |      |     |      |     |      |     |      |     |                   |             |      |     |      |     |      |     |      |     |      |     |      |     |                   |             |
| 800           | 5.1   |          |                 |   |     |     |     |     |     |     |     |     |     |     |     |     |     |     |     |     |     |     |     |      |     |      |     |      |     |      |     |      |     |      |     |      |     |      |     |      |     |                   |             |      |     |      |     |      |     |      |     |      |     |      |     |                   |             |
| 900           | 5.2   |          |                 |   |     |     |     |     |     |     |     |     |     |     |     |     |     |     |     |     |     |     |     |      |     |      |     |      |     |      |     |      |     |      |     |      |     |      |     |      |     |                   |             |      |     |      |     |      |     |      |     |      |     |      |     |                   |             |
| 1000          | 5.3   |          |                 |   |     |     |     |     |     |     |     |     |     |     |     |     |     |     |     |     |     |     |     |      |     |      |     |      |     |      |     |      |     |      |     |      |     |      |     |      |     |                   |             |      |     |      |     |      |     |      |     |      |     |      |     |                   |             |
| 1100          | 5.4   |          |                 |   |     |     |     |     |     |     |     |     |     |     |     |     |     |     |     |     |     |     |     |      |     |      |     |      |     |      |     |      |     |      |     |      |     |      |     |      |     |                   |             |      |     |      |     |      |     |      |     |      |     |      |     |                   |             |
| 1200          | 5.5   |          |                 |   |     |     |     |     |     |     |     |     |     |     |     |     |     |     |     |     |     |     |     |      |     |      |     |      |     |      |     |      |     |      |     |      |     |      |     |      |     |                   |             |      |     |      |     |      |     |      |     |      |     |      |     |                   |             |
| 1300          | 5.6   |          |                 |   |     |     |     |     |     |     |     |     |     |     |     |     |     |     |     |     |     |     |     |      |     |      |     |      |     |      |     |      |     |      |     |      |     |      |     |      |     |                   |             |      |     |      |     |      |     |      |     |      |     |      |     |                   |             |
| 1400          | 5.7   |          |                 |   |     |     |     |     |     |     |     |     |     |     |     |     |     |     |     |     |     |     |     |      |     |      |     |      |     |      |     |      |     |      |     |      |     |      |     |      |     |                   |             |      |     |      |     |      |     |      |     |      |     |      |     |                   |             |
| 1500          | 5.8   |          |                 |   |     |     |     |     |     |     |     |     |     |     |     |     |     |     |     |     |     |     |     |      |     |      |     |      |     |      |     |      |     |      |     |      |     |      |     |      |     |                   |             |      |     |      |     |      |     |      |     |      |     |      |     |                   |             |
| 1600          | 5.9   |          |                 |   |     |     |     |     |     |     |     |     |     |     |     |     |     |     |     |     |     |     |     |      |     |      |     |      |     |      |     |      |     |      |     |      |     |      |     |      |     |                   |             |      |     |      |     |      |     |      |     |      |     |      |     |                   |             |
| 1700          | 6.0   |          |                 |   |     |     |     |     |     |     |     |     |     |     |     |     |     |     |     |     |     |     |     |      |     |      |     |      |     |      |     |      |     |      |     |      |     |      |     |      |     |                   |             |      |     |      |     |      |     |      |     |      |     |      |     |                   |             |
| 1800          | 6.5   |          |                 |   |     |     |     |     |     |     |     |     |     |     |     |     |     |     |     |     |     |     |     |      |     |      |     |      |     |      |     |      |     |      |     |      |     |      |     |      |     |                   |             |      |     |      |     |      |     |      |     |      |     |      |     |                   |             |

## APPENDIX T – FULL LIST OF SCREW HOLE MEASUREMENTS

Yellow – setup failures

| <b>Rib Pair</b> | <b>DIA Hole LL</b> | <b>DIA Hole L</b> | <b>DIA Hole R</b> | <b>DIA Hole RR</b> | <b>Inner Diameter</b> | <b>Loose LL</b> | <b>Loose L</b> | <b>Loose R</b> | <b>Loose RR</b> | <b>AVG Loosening per plate</b> |
|-----------------|--------------------|-------------------|-------------------|--------------------|-----------------------|-----------------|----------------|----------------|-----------------|--------------------------------|
| A1              |                    |                   |                   |                    |                       |                 |                |                |                 |                                |
| A2              | 2.58               | 2.53              | 2.41              | 2.38               | 1.8                   | 0.433           | 0.406          | 0.339          | 0.322           | 0.375                          |
| A3              | 2.7                | broken            | 1.77              | 2.38               |                       |                 |                |                |                 |                                |
| A4              | broken             | broken            | 2.55              | 2.57               | 1.8                   | Unk.            | Unk.           | 0.417          | 0.428           | 0.422                          |
| A5              | 2.23               | 2.14              | 2.19              | 2.03               | 1.8                   | 0.239           | 0.189          | 0.217          | 0.128           | 0.193                          |
| B1              | missing            | missing           | 2.21              | 2.54               |                       |                 |                |                |                 |                                |
| B2              | 2                  | 2.14              | 2                 | 2.16               |                       |                 |                |                |                 |                                |
| B3              | 2.02               | 2.02              | 2.21              | 2.38               | 1.8                   | 0.122           | 0.122          | 0.228          | 0.322           | 0.199                          |
| B4              | 3.92               | broken            | 2.48              | 2.01               | 1.8                   | 1.178           | Unk.           | 0.378          | 0.117           | 0.557                          |
| B5              | 2.12               | 2.11              | 2.5               | 2.08               | 1.8                   | 0.178           | 0.172          | 0.389          | 0.156           | 0.224                          |
| C1              | missing            | missing           | 2.52              | 2.57               | 1.5                   | Unk.            | Unk.           | 0.400          | 0.428           | 0.414                          |
| C2              | broken             | broken            | 2.52              | 2.66               |                       |                 |                |                |                 |                                |
| C3              | 2.48               | 2.6               | 2.85              | 2.54               | 1.5                   | 0.378           | 0.444          | 0.583          | 0.411           | 0.454                          |
| C4              | 2.62               | 2.69              | missing           | missing            |                       |                 |                |                |                 |                                |
| C5              | 2.91               | 2.67              | missing           | missing            |                       |                 |                |                |                 |                                |
| C6              | 2.29               | 2.65              | 2.24              | 2.23               | 1.8                   | 0.272           | 0.472          | 0.244          | 0.239           | 0.307                          |
| D1              | missing            | missing           | 2.94              | 2.78               |                       |                 |                |                |                 |                                |
| D2              | 2.97               | 2.91              | missing           | missing            |                       |                 |                |                |                 |                                |
| D3              |                    |                   |                   |                    |                       |                 |                |                |                 |                                |
| D4              | 2.49               | 2.77              | 2.63              | 2.4                | 1.8                   | 0.383           | 0.539          | 0.461          | 0.333           | 0.429                          |
| D5              | 2.55               | 2.14              | 2.61              | 2.29               | 1.8                   | 0.417           | 0.189          | 0.450          | 0.272           | 0.332                          |
| D6              | 3.06               | 2.87              | missing           | missing            | 1.8                   | 0.700           | 0.594          |                |                 | 0.647                          |
| E1              | 2.3                | 3.05              | 2.8               | 2.26               | 1.8                   | 0.278           | 0.694          | 0.556          | 0.256           | 0.446                          |
| E2              | missing            | missing           | 2.63              | 2.36               |                       |                 |                |                |                 |                                |
| E3              | 2.47               | 2.23              | missing           | missing            |                       |                 |                |                |                 |                                |
| E4              | 2.83               | 2.73              | 2.12              | broken             |                       |                 |                |                |                 |                                |
| E5              | 3.01               | 2.68              | missing           | missing            |                       |                 |                |                |                 |                                |
| E6              | 2.67               | 3.01              | missing           | missing            |                       |                 |                |                |                 |                                |
| F1              | 2.66               | 3.01              | missing           | missing            | 1.8                   | 0.478           | 0.672          | Unk.           | Unk.            | 0.575                          |
| F2              | 2.24               | 2.1               | 2.44              | 2.67               | 1.8                   | 0.244           | 0.167          | 0.356          | 0.483           | 0.313                          |
| F3              | missing            | missing           | 2.34              | 1.77               |                       |                 |                |                |                 |                                |
| F4              | 2.13               | 2.21              | 2.45              | 2.17               | 1.8                   | 0.183           | 0.228          | 0.361          | 0.206           | 0.244                          |
| F5              | 3.78               | 3.08              | 3.24              | 3.01               | 1.8                   | 1.100           | 0.711          | 0.800          | 0.672           | 0.821                          |

|    |        |        |         |         |     |       |       |       |        |       |  |
|----|--------|--------|---------|---------|-----|-------|-------|-------|--------|-------|--|
| F6 | 2.96   | 2.78   | missing | missing |     |       |       |       |        |       |  |
| G1 | 2.25   | 2.15   | 2.11    | 1.74    | 1.8 | 0.250 | 0.194 | 0.172 | -0.033 | 0.146 |  |
| G2 | 2.19   | 2.27   | 2.29    | 2.25    | 1.8 | 0.217 | 0.261 | 0.272 | 0.250  | 0.250 |  |
| G3 | 2.21   | 2.28   | 2.1     | 2.25    | 1.8 | 0.228 | 0.267 | 0.167 | 0.250  | 0.228 |  |
| G4 | 2.12   | 2.15   | 2.26    | 2.15    | 1.8 | 0.178 | 0.194 | 0.256 | 0.194  | 0.206 |  |
| G5 | 2.17   | 2.04   | 1.97    | 1.85    | 1.8 | 0.206 | 0.133 | 0.094 | 0.028  | 0.115 |  |
| G6 | 2.51   | 2.23   | 2.24    | 2.17    | 1.8 | 0.394 | 0.239 | 0.244 | 0.206  | 0.271 |  |
| H1 | 2.37   | 2.67   | 2.36    | 2.52    | 1.8 | 0.317 | 0.483 | 0.311 | 0.400  | 0.378 |  |
| H2 | broken | broken | 2.34    | 3.54    |     |       |       |       |        |       |  |
| H3 | 2.3    | 2.75   | 2.16    | 2.04    | 1.8 | 0.278 | 0.528 | 0.200 | 0.133  | 0.285 |  |
| H4 | broken | broken | 2.85    | 2.77    |     |       |       |       |        |       |  |
| H5 | broken | broken | 2.55    | 2.21    |     |       |       |       |        |       |  |
| H6 | broken | broken | 2.97    | 2.92    |     |       |       |       |        |       |  |
| I1 | 4      | 4.09   | broken  | broken  |     |       |       |       |        |       |  |
| I2 | broken | broken | 2.51    | 2.64    |     |       |       |       |        |       |  |
| I3 | broken | broken | 2.91    | 2.72    |     |       |       |       |        |       |  |
| I4 | broken | broken | 2.26    | 2.14    |     |       |       |       |        |       |  |
| I5 | 2.6    | 2.2    | 2.77    | 2.67    |     |       |       |       |        |       |  |
| I6 | 3.15   | 2.88   | broken  | broken  |     |       |       |       |        |       |  |
| J1 | 2.25   | 2.15   | 2.45    | 2.67    | 1.8 | 0.250 | 0.194 | 0.361 | 0.483  | 0.322 |  |
| J2 | 1.94   | 1.94   | 2.77    | 2.67    | 1.8 | 0.078 | 0.078 | 0.539 | 0.483  | 0.294 |  |
| J3 | 1.94   | 1.97   | 3.02    | 3.1     | 1.8 | 0.078 | 0.094 | 0.678 | 0.722  | 0.393 |  |
| J4 | 2.23   | 2.54   | 2.13    | 2.24    | 1.8 | 0.239 | 0.411 | 0.183 | 0.244  | 0.269 |  |
| J5 | 2.22   | 2.22   | 2.06    | 1.97    | 1.8 | 0.233 | 0.233 | 0.144 | 0.094  | 0.176 |  |
| J6 | 2.43   | 2.67   | 2.18    | 2.21    | 1.8 | 0.350 | 0.483 | 0.211 | 0.228  | 0.318 |  |
| K2 | 2.95   | 3.14   | 2.89    | 3.11    |     |       |       |       |        |       |  |
| K3 | 3.24   | 3.26   | 2.91    | broken  |     |       |       |       |        |       |  |
| K4 | broken | broken | 2.67    | 2.52    |     |       |       |       |        |       |  |
| K5 | broken | broken | 2.74    | 2.55    |     |       |       |       |        |       |  |
| K6 | 2.33   | 2.77   | broken  | broken  |     |       |       |       |        |       |  |



**APPENDIX U – FULL LIST OF TESTED SAMPLES (PASS/FAIL)**

| Sample ID | Test date | Hardware    | Pass/fail        | Sample ID | Test date | Hardware    | Pass/fail        |
|-----------|-----------|-------------|------------------|-----------|-----------|-------------|------------------|
| A1        | 17-Feb    | unicortical | Setup failure    | G1        | 16-Mar    | bicortical  | Fixation failure |
| A2        | 18-Feb    | unicortical | pass             | G2        | 16-Mar    | bicortical  | pass             |
| A3        | 18-Feb    | unicortical | Setup failure    | G3        | 16-Mar    | bicortical  | pass             |
| A4        | 18-Feb    | unicortical | pass             | G4        | 17-Mar    | bicortical  | pass             |
| A5        | 19-Feb    | unicortical | Fixation failure | G5        | 17-Mar    | bicortical  | pass             |
| B1        | 21-Feb    | bicortical  | Setup failure    | G6        | 17-Mar    | bicortical  | pass             |
| B2        | 19-Feb    | bicortical  | Setup failure    | H1        | 24-Mar    | bicortical  | pass             |
| B3        | 20-Feb    | bicortical  | pass             | H2        | 24-Mar    | bicortical  | Setup failure    |
| B4        | 20-Feb    | bicortical  | pass             | H3        | 24-Mar    | locking     | pass             |
| B5        | 21-Feb    | bicortical  | pass             | H4        | 25-Mar    | locking     | Setup failure    |
| C1        | 22-Feb    | 2.0 mm      | pass             | H5        | 26-Mar    | locking     | Setup failure    |
| C2        | 22-Feb    | 2.0 mm      | Setup failure    | H6        | 26-Mar    | locking     | Setup failure    |
| C3        | 24-Feb    | 2.0 mm      | pass             | I1        | 26-Mar    | 2.0 mm DIA  | Setup failure    |
| C4        | 24-Feb    | unicortical | Setup failure    | I2        | 23-Mar    | 2.0 mm DIA  | Setup failure    |
| C5        | 24-Feb    | unicortical | Setup failure    | I3        | 23-Mar    | 2.0 mm DIA  | Setup failure    |
| C6        | 25-Feb    | unicortical | pass             | I4        | 23-Mar    | 2.0 mm DIA  | Setup failure    |
| D1        | 27-Feb    | 2.7 mm      | Setup failure    | I5        | 22-Mar    | unicortical | Setup failure    |
| D2        | 25-Feb    | 2.7 mm      | Setup failure    | I6        | 22-Mar    | unicortical | Setup failure    |
| D3        | -         | 2.7 mm      | Setup failure    | J1        | 18-Mar    | unicortical | pass             |
| D4        | 25-Feb    | locking     | pass             | J2        | 18-Mar    | unicortical | pass             |
| D5        | 27-Feb    | locking     | pass             | J3        | 18-Mar    | unicortical | pass             |
| D6        | 27-Feb    | locking     | pass             | J4        | 18-Mar    | unicortical | pass             |
| E1        | 1-Mar     | compression | pass             | J5        | 21-Mar    | unicortical | pass             |
| E2        | 1-Mar     | compression | Setup failure    | J6        | 20-Mar    | unicortical | pass             |
| E3        | 27-Feb    | compression | Setup failure    | K2        | 22-Mar    | compression | Setup failure    |
| E4        | 27-Feb    | compression | Setup failure    | K3        | 22-Mar    | compression | Setup failure    |
| E5        | 27-Feb    | compression | Setup failure    | K4        | 22-Mar    | compression | Setup failure    |
| F1        | 24-Feb    | locking     | Fixation failure | K5        | 22-Mar    | compression | Setup failure    |
| F2        | 22-Feb    | locking     | pass             | K6        | 22-Mar    | compression | Setup failure    |
| F3        | 22-Feb    | locking     | Setup failure    |           |           |             |                  |
| F4        | 23-Feb    | locking     | pass             |           |           |             |                  |
| F5        | 23-Feb    | compression | pass             |           |           |             |                  |
| F6        | 23-Feb    | compression | Setup failure    |           |           |             |                  |